



Casting Engine Transmission Center

Global Machinery and Equipment Specification Document

Engine Cold Test System Requirements

Document: SP-M-Cold Test System Reqts

Version: G2.0

Published Date: 08-Jan-2010

Specification created and approved by:

***Global GM Manufacturing Engineering
Casting, Engine, & Transmission Center***



Document Management Information

This Specification shall take effect as of the Published Date of the document.

The controlled version of this document is the one stored on the GM CETC Machinery and Equipment Specifications web site. Any printed copy is an uncontrolled copy.

Any questions or comments with respect to this specification should be directed to the Buyer Manufacturing Engineer responsible for the project.

Revision History			
Published	Version	Section Number	Change Description & Impact
19-Sep-2008	G1.0	All	Approved Version Released for Global Project Use.
8-JAN-2010	G2.0	ALL	Approved for Global Release. Content edited to reflect GM reorganized business structure. No major changes to Supplier requirements except as noted below:
		All	Replaced all references to "Repair Station" with "Diagnostic Station", NO TECHNICAL IMPACT ON SUPPLIER DESIGNS.
		1.0	Differentiated intended usage of "Supplier", "equipment supplier", "equipment builder" and "test supplier" within the document, NO TECHNICAL IMPACT ON SUPPLIER DESIGNS.
		1.1	Scope of Document, eliminated the "Injector Information Client (Diesel Only)" component, TECHNICAL IMPACT ON SUPPLIER DESIGNS IS SIMPLIFIED.
		2.0	Updated Definitions and Acronyms lists, NO TECHNICAL IMPACT ON SUPPLIER DESIGNS. Added eSATA as an option to Archive Media choices, "Repair Codes" are now "Diagnostic Codes", Added "Diesel Fuel Control Panel", "Static Ignition Test", "Transfer Unit" "EST", "ODBC", "SNR", "SQL", and others.
		2.1, 3.3.4.5	Moved section "3.3.4.5 Test Step Descriptions" to separate Application Notes. Detailed definition of Test Step Descriptions for Gasoline and for Diesel test applications will be provided as separate requirements in the Application Note. NO TECHNICAL IMPACT ON SUPPLIER DESIGNS.
		3.1	Clarified requirements for shuttling engine in and out of the station. No gap in the conveyor. No added footprint. MAY HAVE A TECHNICAL IMPACT ON SUPPLIER DESIGNS.
		Fig 2	Updated Base Control Architecture diagram to show two weather stations connected directly managed switch via Ethernet instead of with a serial interface, NO TECHNICAL IMPACT ON SUPPLIER DESIGNS.
		3.3.1	Added clarifications and requirements for Transfer Unit, MAY HAVE TECHNICAL IMPACT ON SUPPLIER DESIGNS.
		3.3.2.1	Added statement regarding auxiliary equipment having no NVH impact, MAY HAVE TECHNICAL IMPACT ON SUPPLIER DESIGNS.
		3.3.2.1	Added requirement for push/pull blocks for probes and driveline, MAY HAVE TECHNICAL IMPACT ON SUPPLIER DESIGNS.
		3.3.2.2, Fig 4, Fig 5	Added provision for use of an adapter plate between engine and test station, MAY HAVE TECHNICAL IMPACT ON SUPPLIER DESIGNS.
		3.3.2.2.2	Jaw design for gripping flex-plate must have only two or three clamping points, MAY HAVE TECHNICAL IMPACT ON SUPPLIER DESIGNS.
		3.3.2.3	Stabilizer probes require wedge lock feature, MAY HAVE TECHNICAL IMPACT ON SUPPLIER DESIGNS.
		3.3.2.3	Filter both inlet and outlet diesel fuel lines on pallet, MAY HAVE TECHNICAL IMPACT ON SUPPLIER DESIGNS.
		3.3.2.3	Compliance requirement for electrical probe increased from 2 mm to 3 mm, MAY HAVE TECHNICAL IMPACT ON SUPPLIER DESIGNS
		3.3.2.3	Clarified requirement for replaceable spring loaded pins for electrical connectors. Now requires easily replaceable in under 10 minutes, MAY HAVE TECHNICAL IMPACT ON SUPPLIER DESIGNS.
		Fig 6	Added an example picture of an electrical probe for clarification, NO TECHNICAL IMPACT ON SUPPLIER DESIGNS.
		Fig 7	Added example picture showing features of an accelerometer probe, NO TECHNICAL IMPACT ON SUPPLIER DESIGNS.
		3.3.2.3	Deviation is no longer required for adaptations, now requires explicit statement in supplier proposal, NO TECHNICAL IMPACT ON SUPPLIER DESIGNS.



Document Management Information

		3.3.2.3	Automatic adaptations list now considers engine driven vacuum pump and dipstick seals. GPCM is eliminated from the list, NO TECHNICAL IMPACT ON SUPPLIER DESIGNS.
		3.3.2.3	Deleted requirement for pallet filters on diesel fuel lines, NO TECHNICAL IMPACT ON SUPPLIER DESIGNS. Europe has not experienced a need to filter pallet side connections. They use three stages of filters on the station supply line.
		3.3.2.4, 3.3.2.5	Engine Intake Plumbing and Exhaust Plumbing: illustrations and equations added to clarify sizing requirements eliminated mapping requirement, NO TECHNICAL IMPACT ON SUPPLIER DESIGNS.
		3.3.2.4	Intake Vent System: combination of 2-way and 3-way ball valves, NO TECHNICAL IMPACT ON SUPPLIER DESIGNS.
		Fig 11	Oil Pressure probe figure added, NO TECHNICAL IMPACT ON SUPPLIER DESIGNS
		3.3.2.6	Add allowance for flexible tubing between seal holder and transducer/blocking valve, NO TECHNICAL IMPACT ON SUPPLIER DESIGNS.
		3.3.2.6	Clarifies how tubing is routed after blocking valves, NO TECHNICAL IMPACT ON SUPPLIER DESIGNS.
		Fig 12	Probe / Seal Holder figure updated, NO TECHNICAL IMPACT ON SUPPLIER DESIGNS.
		3.3.2.8.2, 3.3.2.8.5	Changed descriptions for evac and prime options (for in-station verses separate station), Added detail to station requirements, MAY HAVE TECHNICAL IMPACT ON SUPPLIER DESIGNS.
		Fig 13	Diesel Fuel System block diagram replaced with concept drawing, added logic chart to describe functionality, MAY HAVE TECHNICAL IMPACT ON SUPPLIER DESIGNS
		Fig 15, Table 1	Drive Unit Sizing figure and example calculations added, NO TECHNICAL IMPACT ON SUPPLIER DESIGNS.
		3.3.2.11	Added design requirement to sealing fixtures for ease of use, MAY HAVE TECHNICAL IMPACT ON SUPPLIER DESIGNS
		Table 2	Added calculation example for transducer sizing.
		3.3.2.8	Requires use of multiple diesel fuel filter stages, MAY HAVE TECHNICAL IMPACT ON SUPPLIER DESIGNS.
		3.3.2.8.1	Air cleanliness requirement added, MAY HAVE TECHNICAL IMPACT ON SUPPLIER DESIGNS
		3.3.2.8.2, 3.3.2.8.5	Clarified descriptions for evac and prime options (for in-station verses separate station), NO TECHNICAL IMPACT ON SUPPLIER DESIGNS.
		Fig 13	Diesel Fuel System block diagram replaced with concept drawing, added logic chart to describe functionality, MAY HAVE TECHNICAL IMPACT ON SUPPLIER DESIGNS
		Fig 15, Table 1	Drive Unit Sizing figure and example calculations added, NO TECHNICAL IMPACT ON SUPPLIER DESIGNS.
		3.3.2.11	Added design requirement to sealing fixtures for ease of use, MAY HAVE TECHNICAL IMPACT ON SUPPLIER DESIGNS
		Table 2	Added calculation example for transducer sizing.
		3.3.3.7	Deleted discussion about intake throttle body as the only available sensing position, NO TECHNICAL IMPACT ON SUPPLIER DESIGNS.
		3.3.3.7.2	Added preference for direct current measurement over indirect VRS sensor (speed sensor), MAY HAVE TECHNICAL IMPACT ON SUPPLIER DESIGNS.
		3.3.3.7.4	Added resonance clarification for NVH probe design, MAY HAVE TECHNICAL IMPACT ON SUPPLIER DESIGNS.
		3.3.3.7.5	Changed the strategy for selection of oil pressure transducers instead of using a high speed range and a low speed range, we now have a transducer for measuring pressure and a transducer for measuring dynamic pressure. This WILL HAVE A TECHNICAL IMPACT ON SUPPLIER DESIGNS.
		3.3.3.7.7	Added clarification about polarity of Torque Transducer relative to engine, NO TECHNICAL IMPACT ON SUPPLIER DESIGNS.
		3.3.4	The requirement for GFI duplex receptacle and a printer port on the enclosure is redundant, NO TECHNICAL IMPACT ON SUPPLIER DESIGNS. This requirement is covered in the ACL.
		3.3.4.1.1	The delivered computer, at time of purchase, to be fastest available, not to exceed supplier quoted cost, NO TECHNICAL IMPACT ON SUPPLIER DESIGNS.
		3.3.4.1.1	The two required weather stations are referred to as: test area weather station and diagnostic area weather station, NO TECHNICAL IMPACT ON SUPPLIER DESIGNS
		3.3.4.1.2	Softened requirement on use of signal conditioning modules, MAY HAVE TECHNICAL IMPACT ON SUPPLIER DESIGNS.
		3.3.4.2.3.2	Clarified stabilization delays also include engine control commands (cam phaser positioning)
		3.3.4.2.3.3	Clarified data rotation and over sampling requirements to be dependent on cylinder count rather than fixed to 810°, NO TECHNICAL IMPACT ON SUPPLIER DESIGNS.



Document Management Information

		3.3.4.2.3.3	Clarified intended meaning of "real-time" display for Oscilloscope Display to be simulated, not actually "real-time", NO TECHNICAL IMPACT ON SUPPLIER DESIGNS.
		3.3.4.2.3.4	Eliminated a redundant statement for commercially available except for synchronization board, NO TECHNICAL IMPACT ON SUPPLIER DESIGNS.
		3.3.4.2.3.6	Eliminated duplicate requirement to switch between limit sets in less than one minute, NO TECHNICAL IMPACT ON SUPPLIER DESIGNS
		3.3.4.2.3.7	Multilanguage capable to include support for Portuguese, MAY HAVE TECHNICAL IMPACT ON SUPPLIER DESIGNS
		3.3.4.2.3.8	Clarified example to describe use of data analysis as multitasking feature.
		3.3.4.2.3.9	Data display required only in metric engineering units now. Switching between unit types is no longer required, NO TECHNICAL IMPACT ON SUPPLIER DESIGNS
		3.3.4.2.3.13	Calibration screen to include field to record calibration unit serial number, NO TECHNICAL IMPACT ON SUPPLIER DESIGNS
		3.3.4.2.3.13	Clarified intended use of calibration screen is dual purpose, calibration verification and calibration adjustment, NO TECHNICAL IMPACT ON SUPPLIER DESIGNS
		3.3.4.2.4.1	Clarification: With the exception of passwords, there shall not be any commands that have to <i>be</i> remembered..., NO TECHNICAL IMPACT ON SUPPLIER DESIGNS. This change is driven by a previously approved deviation.
		3.3.4.3	Eliminated section for "GPCM Interface (DIESEL ONLY)", NO TECHNICAL IMPACT ON SUPPLIER DESIGNS.
		3.3.4.3	Eliminated the concept of a test phase in favor of test step definitions. Refreshed test sequence tables and test profiles, NO TECHNICAL IMPACT ON SUPPLIER DESIGNS.
		3.3.4.4, 3.3.4.5	Moved Test Step Description tables (setup, and data analysis & storage) to separate application notes, Safety abort tests retained as new section 3.3.4.5, NO TECHNICAL IMPACT ON SUPPLIER DESIGNS.
		3.3.4.5	Modified storage requirements for safety aborts, NO TECHNICAL IMPACT ON SUPPLIER DESIGNS
		3.3.5	Deleted Turbocharger Test section (3.3.5.1)
		3.3.5.1	Added requirement to use application notes for configuration of ignition tests.
		3.3.5.2	Expanded description of "Ignition Only Test" to include static and dynamic test types, MAY HAVE TECHNICAL IMPACT ON SUPPLIER DESIGNS.
		3.3.7	Clarified expectations for motion faults and shunt calibration failures, added flow chart diagrams, MAY HAVE TECHNICAL IMPACT ON SUPPLIER DESIGNS.
		3.5.1	After reboot, the host system and all available clients reconnect automatically, MAY HAVE TECHNICAL IMPACT ON SUPPLIER DESIGNS
		3.5.2.1	Added clarification notes to several bullets related to archiving features and shift hour requirements, NO TECHNICAL IMPACT ON SUPPLIER DESIGNS
		3.5.2.2	Version control requirements updated, MAY HAVE TECHNICAL IMPACT ON SUPPLIER DESIGNS
		3.5.5	<i>"Read" from Archive media automatically instead of "reload". Archive Media is always connected, MAY HAVE TECHNICAL IMPACT ON SUPPLIER DESIGNS</i>
		3.5.5	"Archive Manager" requirements updated to align more closely with current capability and tape drive no longer required, deleted direct reference to ASCII file for looking up EUNs, EACH MAY HAVE TECHNICAL IMPACT ON SUPPLIER DESIGNS
		3.5.6	Remote support alternate physical connections, such as DSL Modems, can be used if preapproved through the deviation process, NO TECHNICAL IMPACT ON SUPPLIER DESIGNS
		3.5.6	Added Microsoft Live Meeting and SSL/VPN as options for remote support, NO TECHNICAL IMPACT ON SUPPLIER DESIGNS
		3.5.6	Remote support sessions are no longer specified to be hosted by GM, a more general statement is provided, NO TECHNICAL IMPACT ON SUPPLIER DESIGNS
		3.6.1	Deleted uptime from requirement, NO TECHNICAL IMPACT ON SUPPLIER DESIGNS - Uptime is calculated by PM&C, not the test application. This change is driven by a previously approved deviation request.
		3.6.3	Clarified; Engine test lists shall have a column (or indicator) for Pass/Fail..., NO TECHNICAL IMPACT ON SUPPLIER DESIGNS – does not have to be a column, just need to be able to distinguish Pass from Fail. This change is driven by a previously approved deviation request.
		3.6.3	Simplified; Instead of "double mouse click" the term "graphically select" is used for selecting data points on SPC graphs, NO TECHNICAL IMPACT ON SUPPLIER DESIGNS. This change is driven by a previously approved deviation request.
		3.6.4	Softened the requirement to show progress bar and percent complete to simply showing the application is "working", NO TECHNICAL IMPACT ON SUPPLIER DESIGNS. This change is driven by a previously approved deviation request.



Document Management Information

		3.6.5	Redefined and moved first time test reporting and production related report information to section 3.6.7.2 Production Report, the redefined terms MAY HAVE TECHNICAL IMPACT ON SUPPLIER DESIGNS.
		3.6.6.5.2	Configuration Options for Histogram report type now includes option to scale y-axis as counts instead of percent of total, MAY HAVE TECHNICAL IMPACT ON SUPPLIER DESIGNS
		3.6.6.6	Trend Graph no longer limits the number of data points displayed per graph, NO TECHNICAL IMPACT ON SUPPLIER DESIGNS.
		3.6.6.8.2	Simplify; subgroups no longer required to be scrollable, NO TECHNICAL IMPACT ON SUPPLIER DESIGNS. This change is driven by a previously approved deviation request.
		3.6.6.9	Frequency Histogram Report requirements updated, MAY HAVE TECHNICAL IMPACT ON SUPPLIER DESIGNS.
		3.6.7.1	Modified sort range criteria for data export to Microsoft Excel format, NO TECHNICAL IMPACT ON SUPPLIER DESIGNS
		3.6.7.2, Fig 23	First time test reporting requirements updated and moved to this section. Example production report added.
		3.6.7.2	Overall Production report now requires the ability to create a list of engines repaired, MAY HAVE TECHNICAL IMPACT ON SUPPLIER DESIGNS. Previous version only required ability to create a list of scrapped engines.
		3.6.7.4	Limit calculator now explicitly states use of engine list instead of just a count of records, MAY HAVE TECHNICAL IMPACT ON SUPPLIER DESIGNS.
		3.6.7.6	Clarification; provided examples of intended use, NO TECHNICAL IMPACT ON SUPPLIER DESIGNS. This change is driven by a previously approved deviation request.
		3.6.7.11	Clarification added to ensure manipulation of the original record is not possible when "Re-Run Old Tests with New Limits" feature is in use, NO TECHNICAL IMPACT ON SUPPLIER DESIGNS
		3.7	"Injector Data Client Requirements (DIESEL ONLY)" section was removed, NO TECHNICAL IMPACT ON SUPPLIER DESIGNS.
		3.7.2.1	Strengthened statement to clarify that the mapping rig and labor is a required activity, not to be an option to purchase on the purchase order.
		3.7.2.1	Mapping requirement for AFM moved/consolidated to this section, NO TECHNICAL IMPACT ON SUPPLIER DESIGNS. It was previously in the Test Setup tables for test phases, these tables were moved to a separate application note.
		3.7.2.2	Clarified the "continue defect mapping" entry is to be considered an option in the purchase order.
		3.7.3	Clarifications added to Calibration Equipment Requirements/Deliverables section, NO TECHNICAL IMPACT ON SUPPLIER DESIGNS.
		3.7.6.4	Software licenses provided to engineer or IS&S, documented proof to show all software has been delivered is now a requirement, NO TECHNICAL IMPACT ON SUPPLIER DESIGNS
		3.7.6.6	Defect mapping report must now be approved before start of preliminary run-off, NO TECHNICAL IMPACT ON SUPPLIER DESIGNS.
		3.7.6.6.4	Clarified defect description for "faulty ignition coil", this is more directly applicable to the assembly of the coil to the engine in a way that would impact the proper operation of the ignition system, NO TECHNICAL IMPACT ON SUPPLIER DESIGNS
		3.7.9.1	Backup and Restore of Server Hard Drives no longer requires use of tape media, digital media is described, MAY HAVE TECHNICAL IMPACT ON SUPPLIER DESIGNS.
		3.7.9.2	Eliminate reference to CD-R/DVD-R restore disk, portable media (USB drive) is now described
		4.2	Added references to new Application Notes to support test step definitions and static spark plug test as separate documents, NO TECHNICAL IMPACT ON SUPPLIER DESIGNS.
		4.3	Updated the language for ease of understanding, eliminated obsolete exponential form equation in favor of polynomial version, NO TECHNICAL IMPACT ON SUPPLIER DESIGNS.
		4.5	Added requirement to allow for torque compensation based on barometric pressure, MAY HAVE TECHNICAL IMPACT ON SUPPLIER DESIGNS.
		Fig 24	Added picture of compensation curve as an example, NO TECHNICAL IMPACT ON SUPPLIER DESIGNS.



Table of Contents

1.0 INTRODUCTION10

1.1 SCOPE OF DOCUMENT10

1.2 LEGAL REQUIREMENTS AND REGULATIONS10

 1.2.1 ORDER OF PRECEDENCE.....10

1.3 INDUSTRY AND INTERNATIONAL STANDARDS10

1.4 RESOLUTION OF CONFLICT10

2.0 DEFINITIONS AND ACRONYMS11

2.1 DEFINITIONS11

 2.1.1 Archive Media11

 2.1.2 Conveyor Controller.....11

 2.1.3 Diesel Fuel Control Panel.....11

 2.1.4 Exhaust Valve Closing (EVC) Position.....11

 2.1.5 Exhaust Valve Opening (EVO) Position.....11

 2.1.6 Host System11

 2.1.7 Intake Valve Closing (IVC) Position11

 2.1.8 Intake Valve Opening (IVO) Position.....11

 2.1.9 Master Pallet.....11

 2.1.10 Post-Close Leak (PCL).....11

 2.1.11 Pre-Open Leak (POL).....11

 2.1.12 Reference Engine12

 2.1.13 Diagnostic PC.....12

 2.1.14 Diagnostic Station.....12

 2.1.15 Report Client PC.....12

 2.1.16 Static Ignition Test12

 2.1.17 Test Instrumentation Cabinet12

 2.1.18 Test Station12

 2.1.19 Test Station Main Panel12

 2.1.20 Transfer Unit.....12

2.2 ACRONYMS13

 2.2.1 AFM™: Active Fuel Management™13

 2.2.2 BDC: Bottom Dead Center13

 2.2.3 DOHC: Dual Overhead Cam13

 2.2.4 ECM: Engine Control Module.....13

 2.2.5 ECU: Engine Control Unit.....13

 2.2.6 EGR: Exhaust Gas Recirculation13

 2.2.7 EST: Electronic Spark Timing13

 2.2.8 EVC: Exhaust Valve Closing.....13

 2.2.9 EVO: Exhaust Valve Opening13

 2.2.10 FPGA: Field Programmable Gate Array.....13

 2.2.11 GPCM: Glow Plug Control Module.....13

 2.2.12 HMI: Human Machine Interface.....13

 2.2.13 HPLT: High Pressure Leak Test (Diesel Fuel)13

 2.2.14 IVC: Intake Valve Closing.....13

 2.2.15 IVO: Intake Valve Opening.....13

 2.2.16 LOMA: Lifter Oil Manifold Assembly.....13

 2.2.17 LPLT: Low Pressure Leak Test (Diesel Fuel).....13

 2.2.18 MU: Metering Unit (Diesel Fuel)13

 2.2.19 NIST: National Institute of Standards and Technology13

 2.2.20 NVH: Noise Vibration Harshness13

 2.2.21 OCV: Oil Control Valve.....13

 2.2.22 ODBC: Open Database Connectivity13



Table of Contents

2.2.23 PB: Push Button 13

2.2.24 PCL: Post-Close Leak 13

2.2.25 PCM: Powertrain Control Module 13

2.2.26 PCV: Positive Crankcase Ventilation 13

2.2.27 POL: Pre-Opening Leak 13

2.2.28 PRV: Pressure Regulating Valve (Diesel Fuel) 13

2.2.29 P/S: Power Supply 13

2.2.30 QD: Quick Disconnect 13

2.2.31 RF Tag: Radio Frequency Identification Tag 13

2.2.32 RPS: Rail Pressure Sensor (Diesel Fuel) 13

2.2.33 RTSI: Real Time Serial Interface 13

2.2.34 SAI: Secondary Air Injection 14

2.2.35 SIDI: Spark Ignited Direct Injection 14

2.2.36 SNR: Signal to Noise Ratio 14

2.2.37 SOR: Statement of Requirements 14

2.2.38 SQL: Structured Query Language 14

2.2.39 TDC: Top Dead Center 14

2.2.40 VDO: Variable Displacement Oil Pump 14

2.2.41 VSI: Vehicle Serial Interface 14

2.2.42 VVT: Variable Valve Timing 14

2.2.43 XDCR: Transducer 14

3.0 REQUIREMENTS 15

3.1 COLD TEST PROCESS OVERVIEW 15

3.2 COLD TEST SYSTEM OVERVIEW 15

 3.2.1 Test Station Overview (Requirements in 3.3) 16

 3.2.2 Diagnostic Station Overview (Requirements in 3.4) 16

 3.2.3 Host System Overview (Requirements in 3.5) 16

 3.2.4 Report Client Overview (Requirements in 3.6) 17

3.3 TEST STATION REQUIREMENTS 18

 3.3.1 Assembly System Integration 18

 3.3.2 Mechanical Design 18

 3.3.3 Electrical Design 30

 3.3.4 Test Instrumentation Cabinet Requirements 33

 3.3.5 Additional Cold Test Types 42

 3.3.6 Test Station/Test System Interfacing 42

 3.3.7 Reject Management - In Station 43

 3.3.8 System Backup and Restore 45

3.4 DIAGNOSTIC STATION REQUIREMENTS 45

 3.4.1 Diagnostic Stand Requirements (see overview in 3.2.2.1) 45

 3.4.2 Diagnostic Cabinet Requirements (see overview in 3.2.2.2) 45

 3.4.3 System Backup and Restore 46

3.5 HOST SYSTEM REQUIREMENTS 46

 3.5.1 Overview 46

 3.5.2 Data Collection/Database Structure 46

 3.5.3 Local Parameter Database 48

 3.5.4 Acquisition 48

 3.5.5 Data Transfer to Server 48

 3.5.6 Remote Diagnostic Support 49

 3.5.7 Backup and Restore 49

3.6 REPORT CLIENT REQUIREMENTS 49

 3.6.1 Quality Gates (detailed separately on the system cost spreadsheet) 49

 3.6.2 Limit Assistant (detailed separately on the system cost spreadsheet) 49

 3.6.3 Data Analysis 49



Table of Contents

3.6.4 Common Report Configuration Requirements 50

3.6.5 Common Report Characteristics 51

3.6.6 Reports 52

3.6.7 Utilities 55

3.6.8 System Backup and Restore 58

3.7 ADDITIONAL REQUIREMENTS/DELIVERABLES 58

3.7.1 Specification Compliance 58

3.7.2 Mapping (detailed separately on the system cost spreadsheet) 58

3.7.3 Calibration Equipment 58

3.7.4 Training 58

3.7.5 Installation and Startup Support 58

3.7.6 Documentation 58

3.7.7 Spare Parts Proposal 60

3.7.8 Preventive Maintenance Plan 60

3.7.9 Disaster Recovery – System Backup and Restore Requirements 60

3.8 BUYER RESPONSIBILITIES 61

3.9 RUN OFF 61

4.0 APPENDICES 63

4.1 INDUSTRY STANDARDS 63

4.1.1 IEC-60204-1 Fourth Edition (2002) Safety of Machinery – Electrical equipment of machines, Part 1: General Requirements 63

4.2 GENERAL MOTORS DOCUMENTS 63

4.2.1 GM Sound Level Specification (GM-1619) 63

4.2.2 Engine Test Approved Components List (CL-M-EngineTestACL) 63

4.2.3 Safety and Ergonomics Specification (SP-S-Safety and Ergonomics) 63

4.2.4 Supplement to IEC-60204-1 (SP-E-60204) 63

4.2.5 GM Laser Alignment Specification No. A1-2004 (GM-1907) 63

4.2.6 GM/Delphi Vibration Standard for Machinery & Equipment (GM-1761) 63

4.2.7 Project Specific Specifications as Outlined in the Bid Package or Project Specific Project Books 63

4.2.8 Assembly System Controls Requirements (SP-E-Assembly Systems Control) 63

4.2.9 Machine and Assembly Run Off Specifications (SP-Q-MARO) 63

4.2.10 Measurement Systems Specification (SP-Q-MSS) 63

4.2.11 Mechanical Specification (SP-M-Mechanical) 63

4.2.12 General Project Specifications (SP-G-General) 63

4.2.13 Training Specification for Manufacturing/Assembly Systems and Equipment (SP-G-Training) 63

4.2.14 Global Manufacturing Drawing Specification Document (SP-G-Drawing) 63

4.2.15 Maintenance of Machinery Specification (SP-G-Maintenance) 63

4.2.16 Roller Conveyor Systems Operational Requirements (SP-M-Roller Conveyor Systems) 63

4.2.17 Hydraulic System Requirements (SP-F-Hydraulic) 63

4.2.18 Lubrication System Requirements (SP-F-Lubrication) 63

4.2.19 Pneumatic System Requirements (SP-F-Pneumatic) 63

4.2.20 Application Note: Engine Cold Test Step Definitions (AN-M-Engine Cold Test Step Definitions) 63

4.2.21 Application Note: Static Spark Plug Test (AN-M-Static Spark Plug Test) 63

4.3 OIL TEMPERATURE CORRECTION 64

4.3.1 Temperature correction shall compensate for a temperature range of 10 °C to 60 °C 64

4.3.2 The coefficients must be double precision and utilize as many decimal positions as possible. Experience shows that at least 10 decimal locations is needed to make the correction accurate. 64

4.3.3 Temperature Correction Mapping Test Plan 64

4.4 INTAKE PRESSURE COMPENSATION 65

4.5 TORQUE COMPENSATION 65



Table of Regional Specific Requirements

No Regional Specific Requirements to date.

Figures

FIGURE 1: TEST SYSTEM OVERVIEW DIAGRAM 15

FIGURE 2: BASE CONTROL ARCHITECTURE 17

FIGURE 3: LOCATE AND CLAMP SYMBOL KEY 18

FIGURE 4: INLINE ENGINE LOCATING AND CLAMPING (TOP - WITHOUT ADAPTER, BOTTOM - WITH ADAPTER)..... 19

FIGURE 5: V ENGINE LOCATING AND CLAMPING (TOP – WITHOUT ADAPTER, BOTTOM – WITH ADAPTER) 19

FIGURE 6: ELECTRICAL PROBE EXAMPLE 21

FIGURE 7: ACCELEROMETER PROBE EXAMPLE 21

FIGURE 8: PRESSURE TRANSDUCER CHAMBER VOLUME ILLUSTRATION 22

FIGURE 9: ENGINE INTAKE PORT VOLUME CALCULATION EXAMPLE 22

FIGURE 10: INTAKE VENT SYSTEM 23

FIGURE 11: ENGINE EXHAUST PORT VOLUME CALCULATION EXAMPLE 24

FIGURE 12: OIL PRESSURE PROBE ENGAGED TO PRESSURE FITTING (TOP VIEW)..... 25

FIGURE 13: PROBE / SEAL HOLDER 25

FIGURE 14: DIESEL FUEL SYSTEM CONCEPT DRAWING (REFERENCE ONLY) 27

FIGURE 15: DIESEL FUEL SYSTEM LOGIC STATE CHART (REFERENCE ONLY) 28

FIGURE 16: DRIVE UNIT SIZING - TORQUE & SPEED VERSES TIME (REFERENCE ONLY) 29

FIGURE 17: TEST STATION DATA ACQUISITION & CONTROL SYSTEM OVERVIEW 34

FIGURE 18: GASOLINE TEST PROFILES (REFERENCE ONLY) 40

FIGURE 19: DIESEL TEST PROFILES (REFERENCE ONLY) 41

FIGURE 20: RETEST STRATEGY (REFERENCE ONLY) FOR SENSOR CHECK (SHUNT CALIBRATION) 43

FIGURE 21: RETEST STRATEGY (REFERENCE ONLY) FOR AUTO RETEST 44

FIGURE 22: TEST SEGMENT WITH EVALUATION CASE ILLUSTRATION..... 45

FIGURE 23: PRODUCTION REPORT EXAMPLE (REFERENCE ONLY)..... 56

FIGURE 24: OIL COMPENSATION CURVE (REFERENCE ONLY) 65

Tables

TABLE 1: CALCULATION EXAMPLE TO VERIFY DRIVE UNIT SIZING..... 29

TABLE 2: CALCULATION EXAMPLE TO VERIFY TRANSDUCER RANGING 32

TABLE 3: GASOLINE TEST SEQUENCE EXAMPLE (REFERENCE ONLY) 40

TABLE 4: DIESEL TEST SEQUENCE EXAMPLE (REFERENCE ONLY)..... 41

Equations

EQUATION 1: NATURAL VOLUME OF ENGINE INTAKE CAVITY 22

EQUATION 2: INTAKE PROBE VOLUME APPROXIMATION..... 23

EQUATION 3: NATURAL VOLUME OF ENGINE EXHAUST CAVITY 23

EQUATION 4: EXHAUST PROBE VOLUME APPROXIMATION 24

EQUATION 5 OIL PRESSURE AS A FUNCTION OF OIL TEMPERATURE 64

EQUATION 6 OIL TEMPERATURE CORRECTION FUNCTION (POLYNOMIAL FORM) 64



1.0 INTRODUCTION

The purpose of this document is to describe the requirements for Buyer's Cold Test system applications. In these specifications, the word "shall" is understood to mean a requirement, the word "should" is understood to be a recommendation, and the phrase "detailed separately" is understood to mean a separate line item shall be included in the system cost spreadsheet.

Supplier, test supplier, and equipment supplier are used throughout this document. The intent is to help delineate who is accountable when the equipment builder (Tier 1) is not the test supplier (Tier 2). The term "Supplier" is interchangeable with the term "equipment supplier" and "equipment builder".

1.1 SCOPE OF DOCUMENT

The intent of this document is to specify the requirements for the following components of the Test System:

1. Test Station.
2. Diagnostic Station.
3. Host System.
4. Report Client.

1.2 LEGAL REQUIREMENTS AND REGULATIONS

The Supplier shall be fully responsible to design, build, and deliver all equipment included within the purchase order agreement in full compliance with governmental laws and regulations applicable to the final destination location for the equipment.

Buyer requirements shall not supersede applicable governmental laws and regulations of the final destination location for the equipment unless a specific exemption has been obtained from the authority having jurisdiction.

1.2.1 ORDER OF PRECEDENCE

Where Buyer requirements, and/or governmental laws and regulations, conflict with one another the manufacturing system design shall adhere to the strictest of these requirements.

1.3 INDUSTRY AND INTERNATIONAL STANDARDS

All machinery and equipment delivered to Buyer, and its' partners adopting these Specifications, by the Supplier shall be designed and built to comply with current industry internationally accepted Standards. GM CETC Specifications may reference various internationally recognized Standards to provide the Supplier with the specific GM interpretation of the Standards requirements that the Supplier shall adhere to and implement in the design of their equipment.

1.4 RESOLUTION OF CONFLICT

Contact the responsible Buyer Manufacturing Engineer in the event of a conflict between the requirements of this document, the references cited herein, or GM CETC Standards and Specifications. The Supplier shall inform the Buyer Manufacturing Engineer responsible for the project of all requirements conflicts. The Buyer Manufacturing Engineer shall direct the Supplier on appropriate action to take in order to resolve the conflict in accordance with Buyer change management procedures.

2.0 DEFINITIONS AND ACRONYMS

2.1 DEFINITIONS

The following definitions apply to this specification:

2.1.1 Archive Media

The digital media that archive data (test results) is stored on. For example, a mass storage hard drive through USB, Firewire 800, eSATA, or Ethernet can serve as digital media. See approved components list, Reference 4.2.2.

2.1.2 Conveyor Controller

The Conveyor Controller manages all pallet traffic in the Test Loop and Diagnostic Area. The HMI for the Conveyor Controller will automatically select test records to display on the Diagnostic PC and will automatically pass the diagnostic codes to the Diagnostic PC.

2.1.3 Diesel Fuel Control Panel

The Diesel Fuel Control Panel, in general will control regulated fuel supply and filtered fuel return flow for the test station, automatic level control, filtering, temperature regulation, and alarm functions.

2.1.4 Exhaust Valve Closing (EVC) Position

The EVC position is a characteristic of the engine cycle that can be measured by the waveform analysis routine to help determine where a defect may lie.

2.1.5 Exhaust Valve Opening (EVO) Position

The EVO position is a characteristic of the engine cycle that can be measured by the waveform analysis routine to help determine where a defect may lie.

2.1.6 Host System

The Host System, Figure 1, in general, will collect all the information that is generated by the Test Station for each individual engine test and distribute test results to a relational database. In addition, this same waveform and test result information is grouped, as a compressed file, by engine unit number (EUN) to a local archive area. The Host System will maintain this local archive area by automatically moving FIFO data to removable media as the local archive area becomes full.

2.1.7 Intake Valve Closing (IVC) Position

The IVC position is a characteristic of the engine cycle that can be measured by the waveform analysis routine to help determine where a defect may lie.

2.1.8 Intake Valve Opening (IVO) Position

The IVO position is a characteristic of the engine cycle that can be measured by the waveform analysis routine to help determine where a defect may lie.

2.1.9 Master Pallet

A Master Pallet is a label assigned to an engine pallet. It is used to send any engine, good or bad, through a test station, generally for mapping purposes or special tests, without fear of the engine leaving the Diagnostic Loop if it passes the test.

2.1.10 Post-Close Leak (PCL)

PCL is a windowed measurement that takes place after the valve of interest (intake or exhaust) is closed during the engine cycle. A change in pressure on the isolated transducer when a valve is supposed to be closed indicates the valve may be leaking or failing to close.

2.1.11 Pre-Open Leak (POL)

POL is a windowed measurement that takes place before the valve of interest (intake or exhaust) is opened during the engine cycle. A change in pressure on the isolated transducer when a valve is supposed to be closed indicates the valve may be leaking or failing to close.



2.1.12 Reference Engine

A Reference Engine is an engine that has built in defects; it is used for test station verification requirements related to the Quality System.

2.1.13 Diagnostic PC

The Diagnostic PC, Figure 1, is the tool for the operator that presents both current and historic, engine-specific test result and waveform information for defect analysis. The intent is to allow the operator to quickly make an intelligent, data driven, decision of the disposition of an engine based on test history.

2.1.14 Diagnostic Station

The Diagnostic Station, Figure 1, provides a work area for engine repair and diagnostics based on information obtained from the Diagnostic Station PC. Engines enter the diagnostic area automatically after a Test Station Reject or Abort. The Cold Test Operator will generally have the ability to quickly determine the disposition of a rejected engine. He will have the ability determine the need for on-line (minor) and off-line (major) repairs.

2.1.15 Report Client PC

The Report/Client PC, Figure 1, has all the statistical tools and reporting functions necessary for the Cold Test Engineer and Quality Systems Engineers to analyze system data and to make production critical decisions. Test result information and waveform analysis tools can be easily analyzed and reported at any level of detail.

2.1.16 Static Ignition Test

The Static Ignition Test is typically a separate test station that allows for analysis of spark plug condition prior to installing the ignition coils. It is considered a static test because there is no need to rotate the crank during this test.

2.1.17 Test Instrumentation Cabinet

The Test Instrumentation Cabinet, Figure 1, typically contains: the test PC, monitor, mouse, keyboard, test control software, uninterruptible power supply (UPS), data acquisition (DAQ) and signal conditioning hardware, variable power supply for ignition system, power supplies for signal conditioning and DAQ I/O, power supplies for engine sensors, calibration test points, engine control hardware for ignition and EST signals, and a panel air conditioning unit. The Test Station Cabinet is generally located directly adjacent to the Test Station to allow operator control of the overall test.

2.1.18 Test Station

The test station, Figure 1, boundaries are generally the on-deck stop, in-station stop, the engine shuttle (transfer unit), the machine frame, probes, slides, pressure transducers, intake and exhaust port vents, torque transducer, timing and ignition system probes/sensors, clamping and locating units, driveline engagement/clamping mechanism, the driveline motor, the shuttle motor, machine guarding, safety interlocks.

2.1.19 Test Station Main Panel

The Test Station Main Panel, Figure 1, typically contains: the main disconnect, safety interlock controller, master control relay, motor starters, relays, the engine drive controller, the shuttle drive controller, control system I/O, the station controller (PLC), interlocks to assembly line, transformers, and panel air conditioning unit.

2.1.20 Transfer Unit

The shuttle Transfer Unit, Figure 1, typically contains: an AC servo drive, pallet locator fixtures, and a mechanism to shift the engine at a high rate of speed into and out of the test station. The transfer unit design must not leave a gap in the conveyor. Pallets must be able to pass through while an engine is in the test position. The transfer unit shall not increase the footprint of the station by using a closing section of conveyor.



2.2 ACRONYMS

The following acronyms apply to this specification:

- 2.2.1 **AFM™: Active Fuel Management™**
- 2.2.2 **BDC: Bottom Dead Center**
- 2.2.3 **DOHC: Dual Overhead Cam**
- 2.2.4 **ECM: Engine Control Module**
- 2.2.5 **ECU: Engine Control Unit**
- 2.2.6 **EGR: Exhaust Gas Recirculation**
- 2.2.7 **EST: Electronic Spark Timing**
- 2.2.8 **EVC: Exhaust Valve Closing**
- 2.2.9 **EVO: Exhaust Valve Opening**
- 2.2.10 **FPGA: Field Programmable Gate Array**
- 2.2.11 **GPCM: Glow Plug Control Module**
- 2.2.12 **HMI: Human Machine Interface**
- 2.2.13 **HPLT: High Pressure Leak Test (Diesel Fuel)**
- 2.2.14 **IVC: Intake Valve Closing**
- 2.2.15 **IVO: Intake Valve Opening**
- 2.2.16 **LOMA: Lifter Oil Manifold Assembly**
- 2.2.17 **LPLT: Low Pressure Leak Test (Diesel Fuel)**
- 2.2.18 **MU: Metering Unit (Diesel Fuel)**
- 2.2.19 **NIST: National Institute of Standards and Technology**
- 2.2.20 **NVH: Noise Vibration Harshness**
- 2.2.21 **OCV: Oil Control Valve**
- 2.2.22 **ODBC: Open Database Connectivity**
- 2.2.23 **PB: Push Button**
- 2.2.24 **PCL: Post-Close Leak**
- 2.2.25 **PCM: Powertrain Control Module**
- 2.2.26 **PCV: Positive Crankcase Ventilation**
- 2.2.27 **POL: Pre-Opening Leak**
- 2.2.28 **PRV: Pressure Regulating Valve (Diesel Fuel)**
- 2.2.29 **P/S: Power Supply**
- 2.2.30 **QD: Quick Disconnect**
- 2.2.31 **RF Tag: Radio Frequency Identification Tag**
- 2.2.32 **RPS: Rail Pressure Sensor (Diesel Fuel)**
- 2.2.33 **RTSI: Real Time Serial Interface**



- 2.2.34 SAI: Secondary Air Injection**
- 2.2.35 SIDI: Spark Ignited Direct Injection**
- 2.2.36 SNR: Signal to Noise Ratio**
- 2.2.37 SOR: Statement of Requirements**
- 2.2.38 SQL: Structured Query Language**
- 2.2.39 TDC: Top Dead Center**
- 2.2.40 VDO: Variable Displacement Oil Pump**
- 2.2.41 VSI: Vehicle Serial Interface**
- 2.2.42 VVT: Variable Valve Timing**
- 2.2.43 XDCR: Transducer**

3.0 REQUIREMENTS

3.1 COLD TEST PROCESS OVERVIEW

This specification was written from the perspective of having a fully automatic test station with an automatic transport to convey engines to/from the station. A deviation request shall be submitted with the proposal to document this information so both the supplier and Buyer are protected in the event any question arises during project execution. The supplier must have a signed deviation request if the specification will not be met.

- The combustion engine is transported to the test station and is connected to an external electric motor (typically a spindle drive motor) via a coupling unit to the engine flexplate or flywheel.
- There is no gap in the pallet conveyor when engine is in test position. Rejects from upstream stations (or untested engines if multiple stations are in series) can pass through the station when engine is in test position.
- Units designed for the connection of sensors and electrical adapters are drawn up.
- For diesel engines, the fuel system is primed.
- The electric motor rotates the engine, which is to be tested, enabling various measurements to be taken in a non-combustion state. The power transmission is carried out via the starter ring gear.
- The engine test cycle is controlled automatically. During the test cycle, the test system controls engine breathing, engine control, and diesel fuel system control. Breathing is accomplished by controlling test stand mounted mechanical vents.
- The engine is motored at various speed set points within the test cycle. The test computer collects data on a high-speed basis. The data is processed through dedicated test algorithms and compared to fixed limits.
- An oil blow down may occur, the flywheel is positioned, for diesel engines fuel is evacuated, memory map data is passed to the pallet RF tag, and the engine is released.

3.2 COLD TEST SYSTEM OVERVIEW

The Cold Test System can be broken into functional components that comprise an entire system:

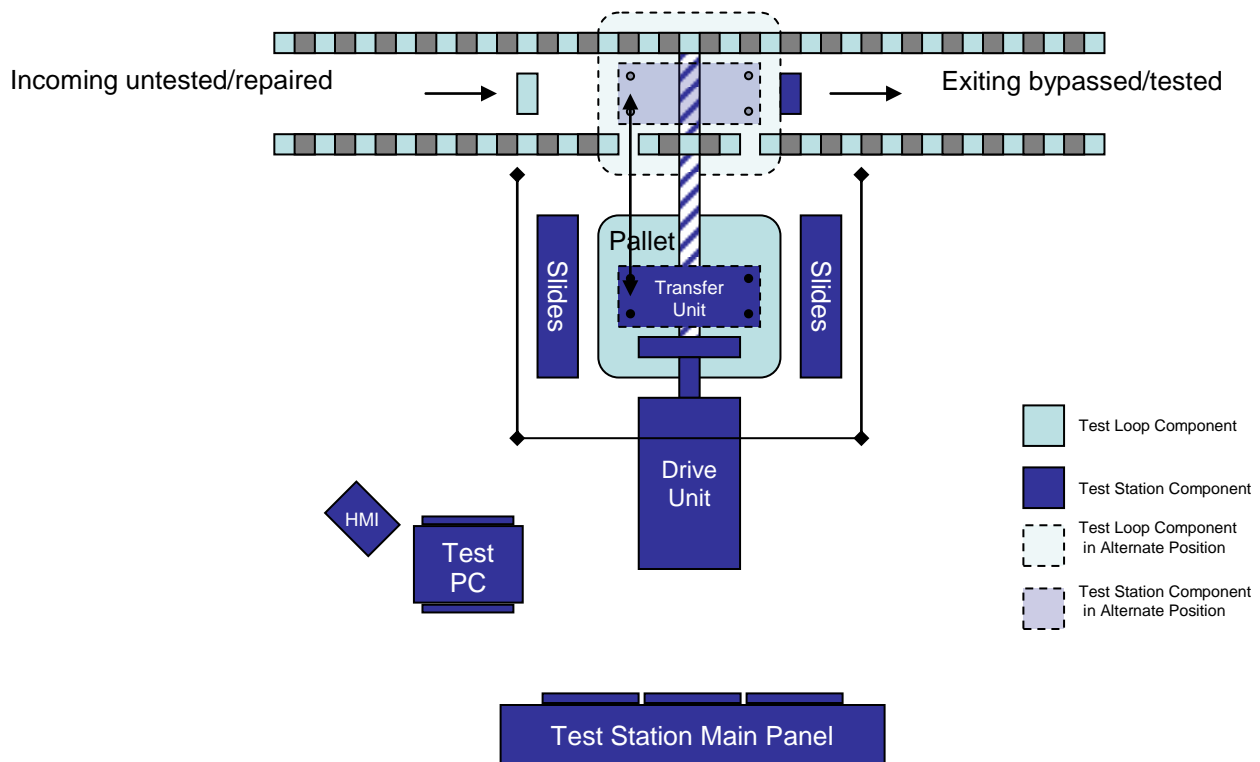

Figure 1: Test System Overview Diagram

3.2.1 Test Station Overview (Requirements in 3.3)

The test station is the most important part of the system. It determines pass/fail status of an engine under test. It is where all the test information is generated. The station can be broken into two subsystems, the Test Stand and the Test Instrumentation Cabinet. See also 2.1.18.

3.2.1.1 Test Stand Overview

The Test Stand is generally the machine base where all machine motion and motion related input/output (I/O) processing occurs. Probes and transducers for engine related signals are also located here. The Test Stand is a slave to the Test Instrumentation Cabinet. See also 2.1.18.

3.2.1.2 Test Instrumentation Cabinet Overview

The Test Instrumentation Cabinet contains the industrial PC that processes, in general, all engine related data acquisition & control (DAC) signals and I/O. Test Control is accomplished through use of specialized Test Software, which executes a Test Plan. The Test Plan sequences Test Step Conditions to the Test Stand (probes, vents, and drive commands) and it performs Engine Control functions that would normally be controlled by the Powertrain Control Module (PCM) or Engine Control Module (ECM) in a vehicle. The Test Software collects engine data, analyses the data, generates the files that contain the Test Results and the Waveform Results, and stores them locally on the PCs hard drive for further processing by the Host System. In addition, the Test Software determines Pass/Fail/Abort status of the engine under test for further processing at the Diagnostic Station, when necessary. See also 2.1.16.

3.2.2 Diagnostic Station Overview (Requirements in 3.4)

The Diagnostic Station supports the Test Station. The Diagnostic Station allows the Diagnostic Operator to determine the disposition of an engine that fails to accept in the Test Station. See also 2.1.14.

3.2.2.1 Diagnostic Stand Overview

The Diagnostic Stand is the Conveyor Controller HMI and is part of the Diagnostic Area. It provides the Diagnostic Operator the tools and controls (HMI) necessary to move engine pallets on-line or off-line based on the disposition determined after analysis at the Diagnostic Cabinet. See also 2.1.2.

3.2.2.2 Diagnostic Cabinet Overview

The Diagnostic Cabinet, in general, contains the Diagnostic PC and a printer. It provides all test related, historical data to the Diagnostic Operator. In general, the Diagnostic Software provides extensive tools both for displaying test results in intuitive formats, and for analyzing waveforms. The Diagnostic Software provides the clues necessary for quick, accurate, intelligent decision making for engine disposition in a production environment. See also 2.1.13.

3.2.3 Host System Overview (Requirements in 3.5)

The Host System is a central location for Test Files and the System Database. It saves engine test files from individual test stands on a periodic basis and distributes individual test point information to a relational database. The Host system acts as the network server and also provides the structure for the network communication between all network components in the Test System Architecture. See paragraph 2.1.6.

3.2.3.1 Test Files Overview

The Test Files are grouped by engine unit number (EUN); they contain all test information related to each engine that has been tested by the Test Station.

3.2.3.2 System Database Overview

The system database is a relational database that centrally stores all the test result information for statistical analysis. It allows for SQL and ODBC compliant connectivity for reporting through various software tools.

3.2.3.3 Network Overview

The network, shown in Figure 2, links the Host System, all Test Stations, the Weather Stations, the Diagnostic Cabinet, and the Report Client with high-speed Ethernet components.

- The Test Network stands alone, independent of the in-plant IT network.

- The production intent Test Network configuration shall be fully set up and implemented on the supplier's floor prior to run-off.
- The equipment supplier is fully responsible for network throughput and configuration issues for all components in the cold test system.
- The supplier shall provide a fully configured connection for the plant IT Network to the managed switch.

3.2.4 Report Client Overview (Requirements in 3.6)

The Report Client pulls information from the Host System and the Host System Database for reporting and analysis functions. See also 2.1.15.

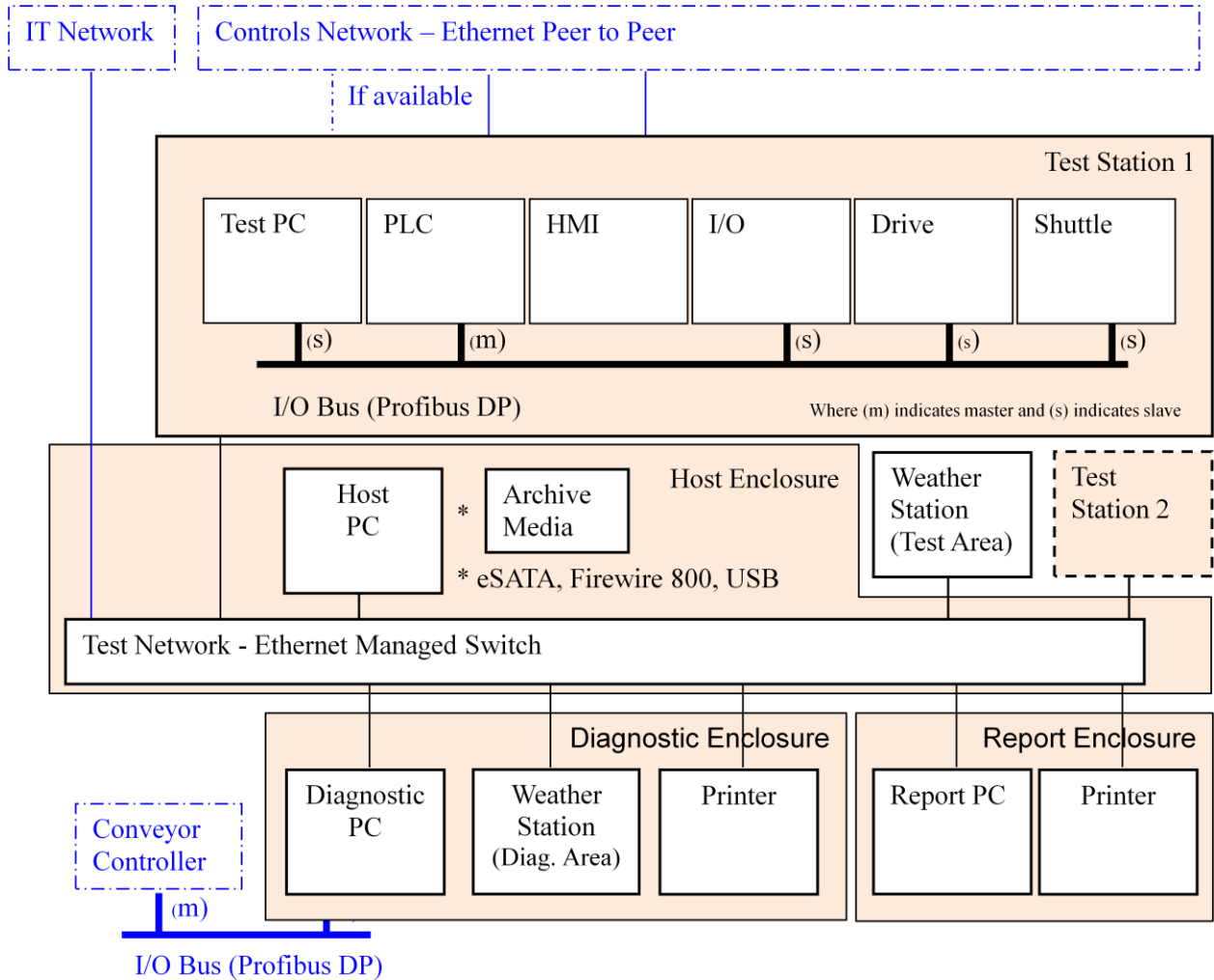

Figure 2: Base Control Architecture

3.3 TEST STATION REQUIREMENTS

3.3.1 Assembly System Integration

- 3.3.1.1 The test station(s) shall be integrated with the assembly system via a pallet transfer unit. The Transfer Unit (see Figure 1 and section 2.1.20) shall be capable of shifting the engine into and out of the station at a high rate of speed (typical 4 seconds in, 4 seconds out).
- 3.3.1.2 The test station interfaces with the pallet conveyor; the engine in front of the test station is pulled into the station via an AC servo driven pallet transfer unit (Figure 1: Test System Overview Diagram).
 - 3.3.1.2.1 The transfer unit does not leave a gap in the transport conveyor when an engine is testing in station. This allows previously rejected engines from upstream stations to proceed directly to the diagnostic area. It also allows any untested engines to bypass if multiple stations are in series.
 - 3.3.1.2.2 The transfer unit shall not increase the footprint of the station by using a closing section of conveyor.
 - 3.3.1.3 The transfer unit pulls the engine into a fixed drive unit. The transfer unit must present the engine for accurate locating and clamping.

3.3.2 Mechanical Design

See Reference 4.2.11

3.3.2.1 Machine Base Requirements

- The test station shall be of three-sided back-in construction. The base quotation is to include a pallet transfer unit shuttling into a fixed engine drive unit.
- Design for a minimum clearance envelope of 15 cm around the engine boundaries. To meet cycle time requirements, it is acceptable to set the return positions of slides/probes inside the 15 cm envelope but the slide design must allow for the full clearance envelope in order to allow for future component design changes. Consideration for proliferation including but not limited to the intake manifold, spark plug wires, lift brackets, adapter plates, and coolant pipes must be taken into account.
- In order to not impact NVH data collection, the stand shall be mounted on isolation pads and not attached to the conveyor.
- All auxiliary support equipment that could influence NVH data collection shall be isolated from the machine for sound and NVH.
- See Reference 4.2.5 for definition of Geometric/Machine Base Leveling & Alignment requirements.
- Push/Pull blocks shall be provided for alignment of fixtures and drive line.

3.3.2.2 Driveline/Engine Engagement and Clamping

Machine motions (test motions), including part-to-part pallet transfer, locating, clamping and unclamping shall not exceed 20 seconds cycle time.

3.3.2.2.1 Part Locating and Clamping Requirements:

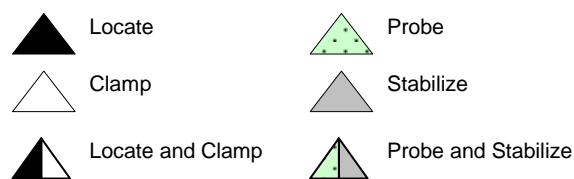

Figure 3: Locate and clamp symbol key

3.3.2.2.1.1 Inline Engines

The pallet is located. The engine is located on the machining locating holes on the transmission mounting flange and clamped on the transmission flange. In the case of an adapter plate between the rear flange and the test station, the adapter would provide an alternative locating and clamping surface for the test station. The force of the exhaust probe

is equalized with a stabilizer. A vertical stabilizer applies downward force to the right front side* (typical) of the engine (see Figure 4).

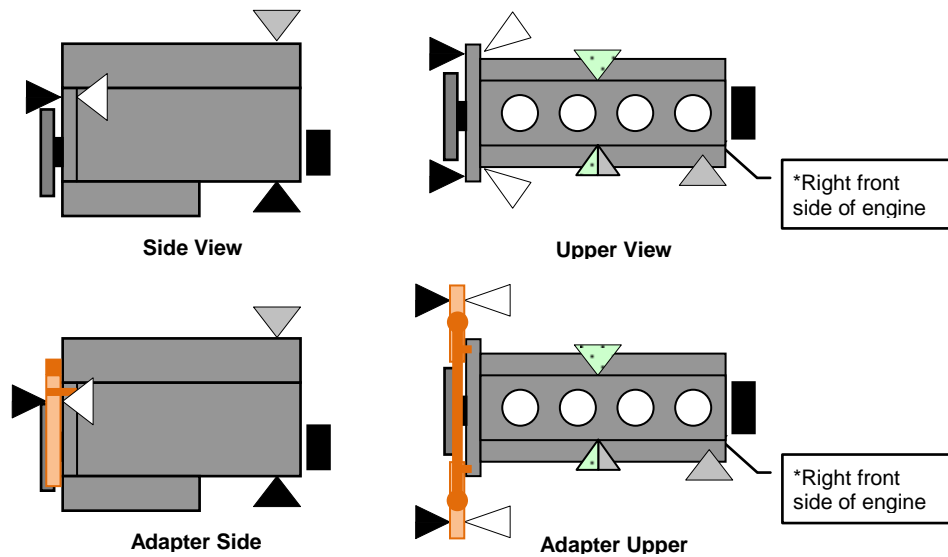

Figure 4: Inline Engine locating and clamping (top - without adapter, bottom - with adapter)

3.3.2.2.1.2 V Engines

The pallet is located. The engine is located on the machining locating holes on the transmission mounting flange and clamped on the transmission flange. In the case of an adapter plate between the rear flange and the test station, the adapter would provide an alternative locating and clamping surface for the test station. The upward force of the exhaust probes is counter opposed by an overhead stabilizer. The sideways force of one exhaust probe is equalized by the opposite exhaust probe.

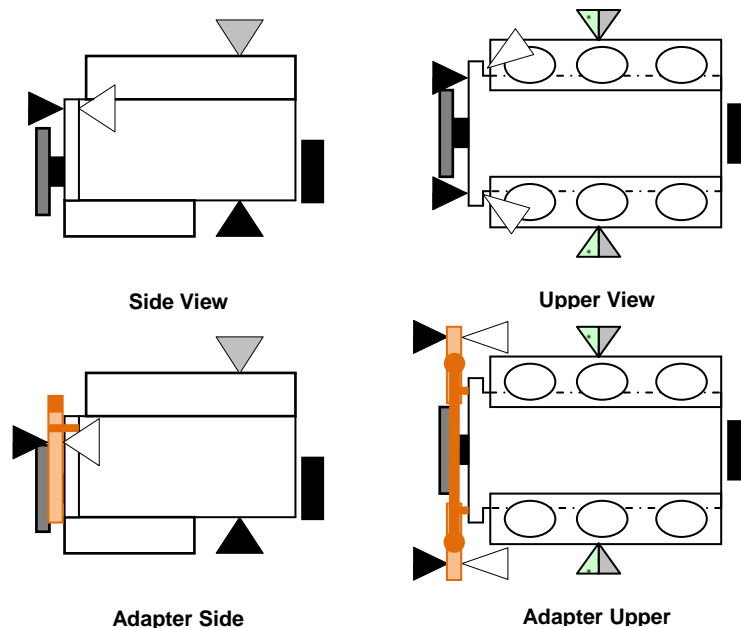

Figure 5: V Engine locating and clamping (top – without adapter, bottom – with adapter)

3.3.2.2.2 Driveline/Engine engagement requirements:

- Design the engine clamps to allow the drive to turn the engine with both the intake and exhaust slides returned.



- Engine clamping shall not cause any physical damage to the part and should eliminate the potential for NVH from outside sources.
- If a hydraulic system is required for engine clamping, then the drive hydraulic pump with an AC electric motor shall be located outside machine guarding for maintenance access. If the hydraulic pump is required to run during engine testing, then the hydraulic system must have vibration isolation from the test station.
- The driveline shall use pivot point and leveraged centrifugal weighting as the primary means of clamping to the flywheel. A small clamp cylinder is necessary to begin engine rotation, but once RPM increases, the centrifugal forces increase the engagement pressure.
- Jaw design for gripping the flex plate shall use only two or three clamping points.
- The driveline shall have a mechanical over-torque protection device. For diesel applications, since the drive must be sized to stop a runaway motor (dieseling), the over-torque protection design must comprehend this, while still protecting station components, such as the torque transducer and driveline components. This would imply a disk brake might be required to protect the driveline and to stall the engine if it starts dieseling.
- Size the driveline to allow rotation to the maximum design speeds without engagement to an engine.
- Engineer the driveline to minimize air disturbance noise associated with high RPM. The design of the flywheel adapter shall minimize any "fan noise" effect. The station shall meet Buyer general equipment noise specifications (Reference 4.2.1).
- Dynamically balance the driveline to meet requirements of Reference 4.2.6. Base the driveline "Vibration Limits" on the "Precision Machine Tools" section of the specification.
- Design requirements for driveline balance shall allow for replacement of perishable details without rebalancing the entire driveline.
- The driveline shall have features for mounting vibration analysis transducers and documentation in compliance with Reference 4.2.6 "Measurement Requirements for Machine Certification".
- The supplier is responsible for performing and passing a driveline vibration analysis prior to run-off and after installation. Reference 4.2.6
- A laser alignment fixture shall be created and shipped with the test station to be used prior to engine mapping at the equipment supplier site and during installation at the plant site. Reference 4.2.5.
- The laser alignment fixture must represent the nominal engine crankshaft centerline in the test position. It will have the necessary features to allow for the shaft-to-shaft coupled laser alignment procedure.
- The driveline shall have features for mounting laser alignment equipment in compliance with Reference 4.2.5.

3.3.2.3 Probe/Seal Engagement

- Probes/Seals shall not damage or put unacceptable permanent marks on the engine components.
- Stabilizer probes shall use a wedge lock mechanism to improve clamping robustness. Rod locks tend to wear and allow for more vibration over time.
- Intake and exhaust sealing fixtures shall have 1 mm compliance in all directions.
- The oil pressure-fitting probe (Figure 12) shall accommodate 12 mm compliance in z-plane and 1 mm compliance in x & y-planes.
- The oil pressure-fitting probe shall protect for missing oil pressure fittings. An over-travel fault condition shall abort the test to prevent oil spillage during engine rotation.
- The oil pressure-fitting probe shall protect for oil drips when engaging/disengaging by use of a drip pan or other engineered oil containment method. The design shall allow for easy cleaning and removal of oil.
- The oil pressure-fitting assembly used in cold test must be compliant with the assembly system (i.e. oil fill/leak test).
- Oil lines, when used, shall use clear tubing so oil, air bubbles, chips, etc. can be seen in the lines.
- Diesel fuel supply and return probes shall be engineered to engage engine pallet match-plate so that fuel spills are automatically prevented (examples; during priming, evacuation, return all units, and emergency stops).
- Diesel fuel supply and return probes shall protect for drips when engaging/disengaging by use of a drip pan or other engineered containment method. The design shall allow for easy cleaning and removal of fuel.
- For diesel applications, the intake probe shall remain sealed to the engine under emergency stop and all engine testing abort conditions. The intake vent default position (loss of air pressure or power) shall be closed. This is to ensure the engine breathing can be shut off if the engine is dieseling.
- All automatic connections to electrical devices (Figure 6) shall utilize free-floating, self-locating connection systems with at least ± 3.0 mm movement capability in x & y-planes and $\pm 5^\circ$ in the connector axial centerline

plane. The connection shall use easily replaceable (gold plated) spring-loaded pins designed to assure no side loading or bending of engine sensor pins. Easily replaceable means an unskilled operator can change the pins in under 10 minutes.

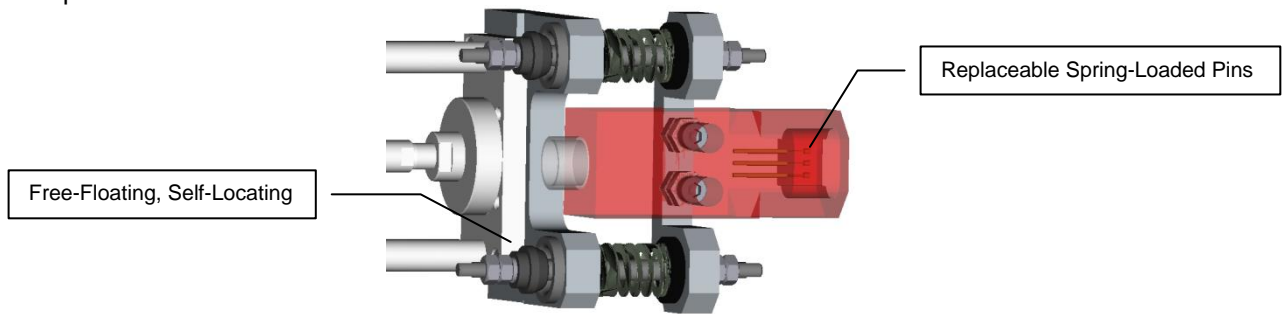

Figure 6: Electrical Probe Example

- The ignition probe design shall ensure the sensor directly contacts the ignition coil at the optimum signal location determined through mapping. The equipment supplier shall provide an alignment tool to ensure the sensor is aligned within ± 1.0 mm relative to the coil in all directions. The tool shall also be used to ensure the angular position of the sensor holder relative to the coil is the same for all sensor locations.
- The ignition/NVH probe design, for each sensor, shall be spring loaded to ensure positive contact with the part, independent of part variation in the z-plane.
- The NVH probe design must provide positive visual indication during setup that the probe contact force on the part is correct and repeatable.
- The NVH probe design must allow for easy removal of the accelerometer to perform calibration.

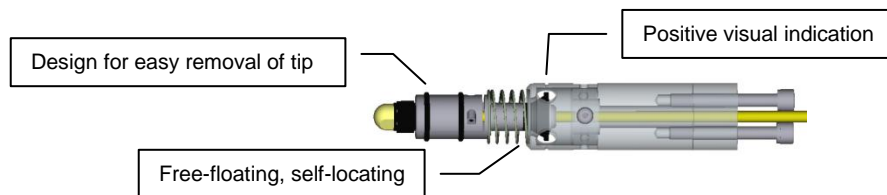

Figure 7: Accelerometer Probe Example

- The supplier is responsible for determining the need for all adaptations required for the proper testing of the engine. The supplier shall list all adaptations from the list below that are not required in the proposal's technical description. Any additional adaptations that will be required that are not included in the list below shall also be identified by the supplier in their technical description.
- When required by engine design, automatic adaptations shall be provided to accommodate the following, at a minimum:
 1. Drive System
 2. Counter Stay (Clamping)
 3. Intake
 4. Exhaust
 5. Cam Sensor(s)
 6. Crank Sensor
 7. Oil Fill Hole (valve cover/customer use)
 8. Oil Pressure
 9. Oil Temperature
 10. Oil Control Valve (OCV) Connectors (i.e. cam phasing, variable valve lift, etc.)
 11. Lifter Oil Manifold Assembly (LOMA)
 12. Ignition System
 13. Coil Pickups
 14. Block Accelerometer(s) (NVH)
 15. Cylinder Head Accelerometer(s)

16. Supercharging
17. PCV Seal/Vent
18. Secondary Air Injection (SAI) Port Seal(s)
19. Evaporator Purge Seal
20. Engine driven vacuum pump
21. Dipstick Seal(s)
22. EGR Pad
23. Fuel Pump mating surface (Diesel)
24. Fuel System (Diesel) to include:
 - Fuel supply
 - Fuel return
 - Fuel pressure sensor
 - Pressure regulating valve
 - Metering valve

3.3.2.4 Engine Intake Plumbing

- The pressure transducer chamber (PTC) on the stand side shall be sized relative to the volumes in each individual cylinder port (including combustion volume). One transducer per port is required (could be individual cylinder ports or combined bank port depending on engine design).
- If the port volumes in the engine are different for some reason, then the supplier shall compensate the volume of the individual stand side pressure chambers to make all pressure readings (volumes) look equivalent. The intent is to compare common measurement ports (cylinders, banks, etc.) against each other to help isolate defects.

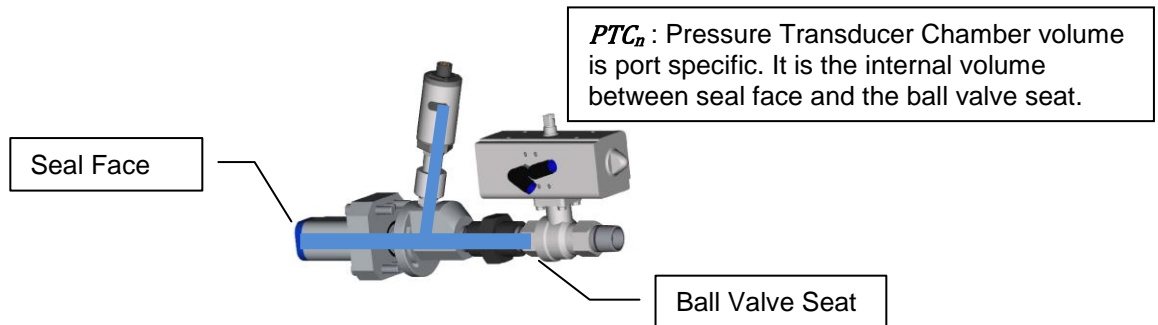
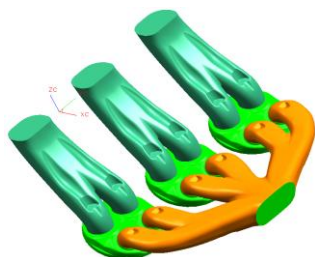

Figure 8: Pressure Transducer Chamber Volume Illustration

Equation 1: Natural Volume of Engine Intake Cavity

$$NVI_n = VI_n + VC_n$$



VI_n	= Intake Port Volume (green) – port n
VC_n	= Combustion Chamber Volume (lime green) – port n
NVI_n	= “natural volume of the engine intake cavity” – port n

Figure 9: Engine Intake Port Volume Calculation Example

- A targeted intake vacuum, approximately 85 % of the intake maximum vacuum as measured in a “zero volume” pressure chamber shall be achieved by fixing the volume of the test stand pressure chamber. A “zero volume” pressure chamber is the “natural volume of the engine intake cavity” (Figure 9) as measured at the intake port with a flat plate covering the port.. Consideration must include cylinder deactivation, variable valve

timing, integrated exhaust and SAI. The purpose of this requirement is to achieve both maximum SNR and minimum volume.

Equation 2: Intake Probe Volume Approximation

$$\frac{NVI_n}{(PTC_n + NVI_n)} = \text{approximately } 85 \%$$

- 2-way leak free ball valves (intake vents) shall be provided on the intake slide plumbing. Leak free is defined as (0.10kpa/10s maximum allowable starting at calibration pressure for the transducer the valve isolates).

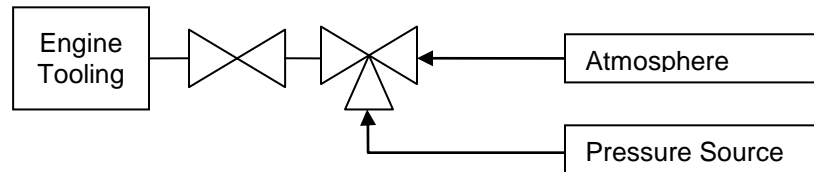

Figure 10: Intake Vent System

- 3-way ball valves shall be provided in series with the intake vents to allow selection between naturally aspirated and supercharged pressure source. The two valves in series will comprise the “intake vent system”.
- The intake vent system shall have the following three modes controlled by the test stand:
 1. *Fully open* - open to atmosphere (selected with 3-way valve)
 2. *Fully closed* – closed off to atmosphere (selected with 2-way valve)
 3. *Ported to pressure source* - The ported to pressure source is also known as supercharging. Under this condition, 0.2 to 0.8 bar of filtered regulated air pressure is used to significantly increase cylinder pressures and hence, sensitivity to compression related defects (selected with 3-way valve).
- Supercharging shall be provided for engine designs with more than one intake or exhaust valve per cylinder (supercharging may be required for single valve engines, determined by engine mapping).
- The test stand shall be capable of running with the intake port open by either opening the intake vent or returning the intake slide. The intent to return the intake slide is for manual operation and for troubleshooting purposes (Buyer noise specifications shall always be met for any configuration selected for use in regular production).
- For diesel applications, the intake plumbing design shall have provisions to shut off breathing to the engine during a runaway (dieseling) event in order to help shut down the engine.

3.3.2.5 Engine Exhaust Plumbing

- The pressure transducer chamber (PTC) on the stand side shall be sized relative to the volumes in each individual cylinder port (including combustion volume). One transducer per port is required (could be individual cylinder ports or combined bank port depending on engine design).
- If the port volumes in the engine are different for some reason, then the supplier shall compensate the volume of the individual stand side pressure chambers to make all pressure readings (volumes) look equivalent. The intent is to compare cylinders against each other to help isolate defects.

Equation 3: Natural Volume of Engine Exhaust Cavity

$$NVE_n = VE_n + VC_n$$



VE_n	= Exhaust Port Volume (grey) – port n
VC_n	= Combustion Chamber Volume (dark green) – port n
NVE_n	= “natural volume of the engine exhaust cavity” – port n

Figure 11: Engine Exhaust Port Volume Calculation Example

- A targeted exhaust maximum pressure, approximately 85 % of the exhaust maximum pressure as measured in a “zero volume” pressure chamber, shall be achieved by fixing the volume of the test stand pressure chamber. A “zero volume” pressure chamber is the “natural volume of the engine exhaust cavity” (Figure 11) as measured at the exhaust port with a flat plate covering the port. Consideration must include cylinder deactivation, variable valve timing, integrated exhaust and SAI. The purpose of this requirement is to achieve both maximum SNR and minimum volume.

Equation 4: Exhaust Probe Volume Approximation

$$\frac{NVE_n}{(PTC_n + NVE_n)} = \text{approximately } 85 \%$$

- 2-way leak free ball valves (exhaust vents) shall be provided on the exhaust slide plumbing. Leak free is defined as (0.10kpa/10s maximum allowable starting at calibration pressure for the transducer the valve isolates)).
- The exhaust vents shall have the following two positions controlled by the test stand:
 1. *Fully open* - open to atmosphere. In the fully open stage, the vent shall be able to flow stand design maximum RPM engine exhaust with a backpressure no greater than 10kPa.
 2. *Fully closed* - closed off to atmosphere
- The test stand shall be capable of running with the exhaust port open by either opening the exhaust vent or returning the exhaust slide. The intent to return the exhaust slide is for manual operation and for troubleshooting purposes (Buyer noise specifications shall always be met for any configuration selected for use in regular production).

3.3.2.6 Pressure Transducer Locations

- For maximum signal energy, transducers shall be located at the source of signal.
- The volume being measured shall always be as small as possible.
- If flexible hoses or tubes must be used in a circuit for pressure / vacuum transducer measurements, then the hoses shall be designed to be flexible enough to allow for movement of the probe mechanism yet rigid enough to not change volume with pressure pulsations. Buyer responsible engineer shall approve material to be used.
- There shall be no right angle bends in the rigid tubing so that best signal quality is achieved.
- The design shall always have the transducer located at the probe seal holder (Figure 13) If this is physically impossible, then tubing may be used with Buyer test engineer approval.
- When possible, the transducer shall be inline or at a maximum 45° from inline to the port being measured. Avoiding 90° turns is critical to good signal response.
- To avoid collection of condensation and dirt, the intake and exhaust transducers shall be located so that they are not the low point in the system and not in an orientation that allows foreign material to collect.
- There shall be one transducer per cylinder located at the exhaust port for the exhaust pressure test.
 - For “exhaust-in-head” variants (Figure 9), where the exhaust ports are combined), there shall be one transducer per intake port and one per head exhaust outlet.
 - For “intake-in-head” variants, there shall be one transducer per intake bank and one on each exhaust port.
- The distance between the port probe seal and the vent (Figure 13) shall be minimized.
- The tube/piping after the blocking valves shall be symmetric and have an equal length and diameter for all measurement channels.
- Sound abatement methods must not significantly impact the ability of the engine breathing during the test.

- Oil pressure transducers shall be located at the engine quick disconnect (QD).
- Oil pressure plumbing shall be designed to be lower than connection point to assist in the purging of air from the measurement loop.

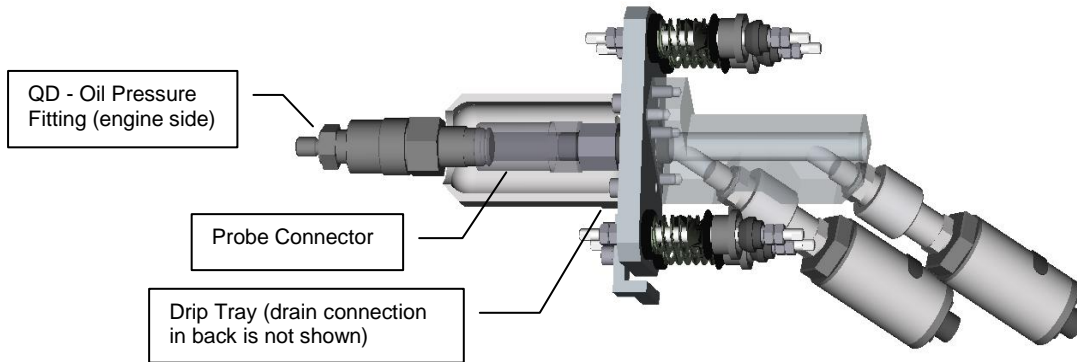

Figure 12: Oil Pressure Probe engaged to pressure fitting (top view)

3.3.2.7 Seals

- All intake and exhaust seals shall be long life and of a quick-change design. The definition of quick change is that a non-skilled operator with no or only simple tools can replace the seals.
- The seals are to be standard items or the seal molds shall be the property of Buyer.

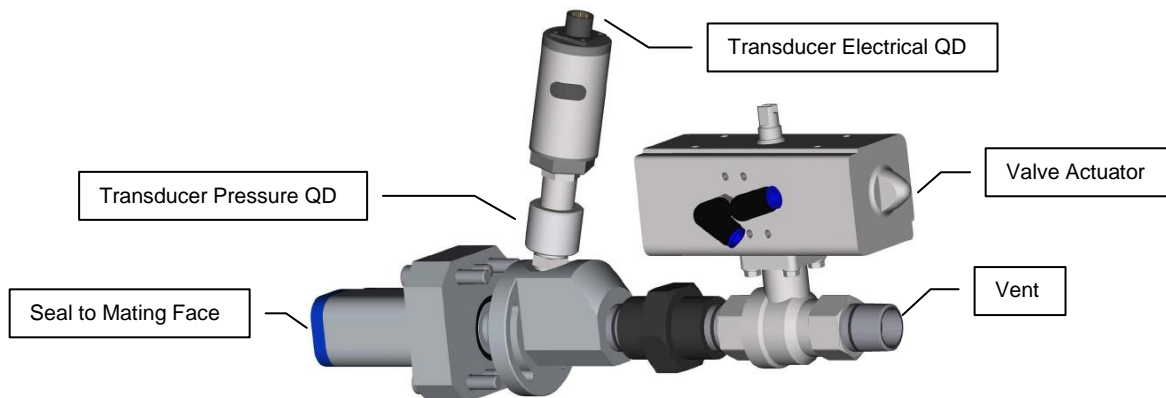

Figure 13: Probe / Seal Holder

3.3.2.8 Diesel Fuel System (see Figure 14 and Figure 15)

- The diesel fuel system shall provide clean (5 μm absolute filter), conditioned (temperature) and pressure regulated Diesel feed to the engine.
- Multiple stages of selectable filters will be necessary to prevent premature blockage of the selectable five μm absolute filter. The selectable filters shall allow for changing out expended filters while providing uninterrupted service to cold test and evacuation stations.
- The system is filled only for lubricating the high-pressure pump and checking for fuel system leakage, **no Diesel injection** and **no Diesel in combustion chamber**.
- Proper ventilation and control of fumes must be integrated into the each station by the equipment supplier and be designed to interface to plant facilities ventilation system.
- Design safeties/interlocks into the system to prevent accidental fuel spills, and to prevent the engine from dry cycling the fuel pump. This applies to all modes of operation.
- Provide engineered containment of all potential fuel spill points at system maintenance locations and at the engine test station. Collect excess fuel in a drip pan that encompasses the entire station. Design a central collection point for easy disposal and clean up.
- Design guarding to protect potential fuel spray areas from contaminating station and operators.

3.3.2.8.1 Diesel Fuel Low Pressure Leak Test (LPLT)

- The system shall perform a gross leak test prior to allowing fuel transfer to the engine. The purpose of the gross test is to check, to the extent possible, for disconnected/damaged fuel lines, unfastened fuel lines, and improper probe connections so that no inadvertent fuel spills occur at the start of the priming operation.
- For assembly systems that have a gross leak test prior to cold test, then this leak test requirement is limited to a positive confirmation that the fuel probes are engaged.
- The supplier shall follow the engine fuel-system supplier's recommendation for cleanliness of air introduced for leak testing.

3.3.2.8.2 Diesel Fuel Priming (detailed separately on the system cost spreadsheet)

- The diesel fuel system shall provide fuel priming to the engine prior to start of test. The priming operation shall ensure fuel is present at the pump suction prior to spinning the fuel pump. Provide positive feedback to ensure the engine has enough fuel.
- The priming tank and the intermediate tank at the test station shall have fully integrated level control, temperature control, level indication, and alarm functionality.
- Temperature control at the intermediate tank for the test station may be accomplished cost effectively through continuous recirculation of the conditioned fuel from the priming tank.
- The priming station shall provide distributed, filtered, temperature regulated and pressure regulated fuel to each cold test station. Interlocks and lockout provisions are required so that a complete lockout of any station can occur for maintenance while other stations remain in operation.
- The priming tank will provide an interlocked method to receive and filter, typical 50 μm , recovered fuel from the evacuation station.
- Size the priming tank so that the evacuation tank can always pump back at least one tank volume, even after the priming tank is automatically filled.
- Temperature regulation shall be programmable and adjustable. Typical target temperature for planning purposes should be $43\text{ }^{\circ}\text{C} \pm 3\text{ }^{\circ}\text{C}$
- Maintain temperature regulation at the priming tank and at the cold test stations even after a fill cycle or evacuation recovery cycle.
- If there is a plan identified in the SOR to protect for a future cold test station, then the supplier shall design the priming station to handle the additional capacity without significant modification to the purchased priming station. This means that the supplier would only have to add modular hardware details for the new test station to the purchased priming station.
- The equipment supplier shall quote an option for fuel priming.
 - The baseline is to include all costs for the priming equipment as a separate, independent priming station outside the cold test station..
 - The quoted option is to provide the cost savings to integrate the priming station fully into the cold test station. A detailed technical description is required.

3.3.2.8.3 Diesel Fuel Control

- The test software shall provide full control of fuel pressure using closed loop PWM control over fuel system regulating components.
- Regulate and monitor fuel pressure throughout the engine test to enable fuel system leak testing and provide for continuous safety aborts.
- In the event of a fuel related abort or an engine runaway (dieseling) condition, the system shall provide for immediate fuel safety shutoff.

3.3.2.8.4 Diesel Fuel High Pressure Leak Test (HPLT)

- The test software shall be capable of performing a fuel system leak test at any engine RPM, even as the engine is stopped at the end of the test.
- For example, command a specific fuel pressure at a fixed engine speed. Stabilize fuel pressure, and then stop pressure control while maintaining a fixed engine speed. Perform a pressure decay test.
- An alternate scenario would be to issue a fuel pressure command while at a fixed engine speed. Once fuel pressure is stabilized, the engine is stopped while closing the regulating valves to trap pressure in the rail. Perform a pressure decay test.

3.3.2.8.5 Diesel Fuel Evacuation (detailed separately on the system cost spreadsheet)

- The diesel fuel system shall provide for flexible, consistent, evacuation and purging of Diesel after test to minimize remaining fuel in system so that fuel lines can be safely disconnected (drip free). Flexible means the operator will be able to adjust the volume of remaining fuel accurately.
- Allowed residual fuel will be determined and agreed between Buyer and the equipment supplier during design phase. Some residual fuel is required for initial startup at the vehicle assembly plant.
- The equipment supplier shall quote an option for fuel evacuation.
 - The baseline is to include all costs for the evacuation equipment inside the cold test station.
 - The quoted option is to provide only the added cost that is not included in the baseline, for a separate, independent evacuation station outside the cold test station. This implies that supplier would move the quoted evacuation components (from the baseline proposal) to the independent evacuation station, without additional cost, and then add the cost for additional components. If Buyer does not select this option at the start of the design phase, then Buyer would be responsible for additional cost. A detailed technical description is required.

COLD TEST DIESEL FUEL SYSTEM CONCEPT DRAWING

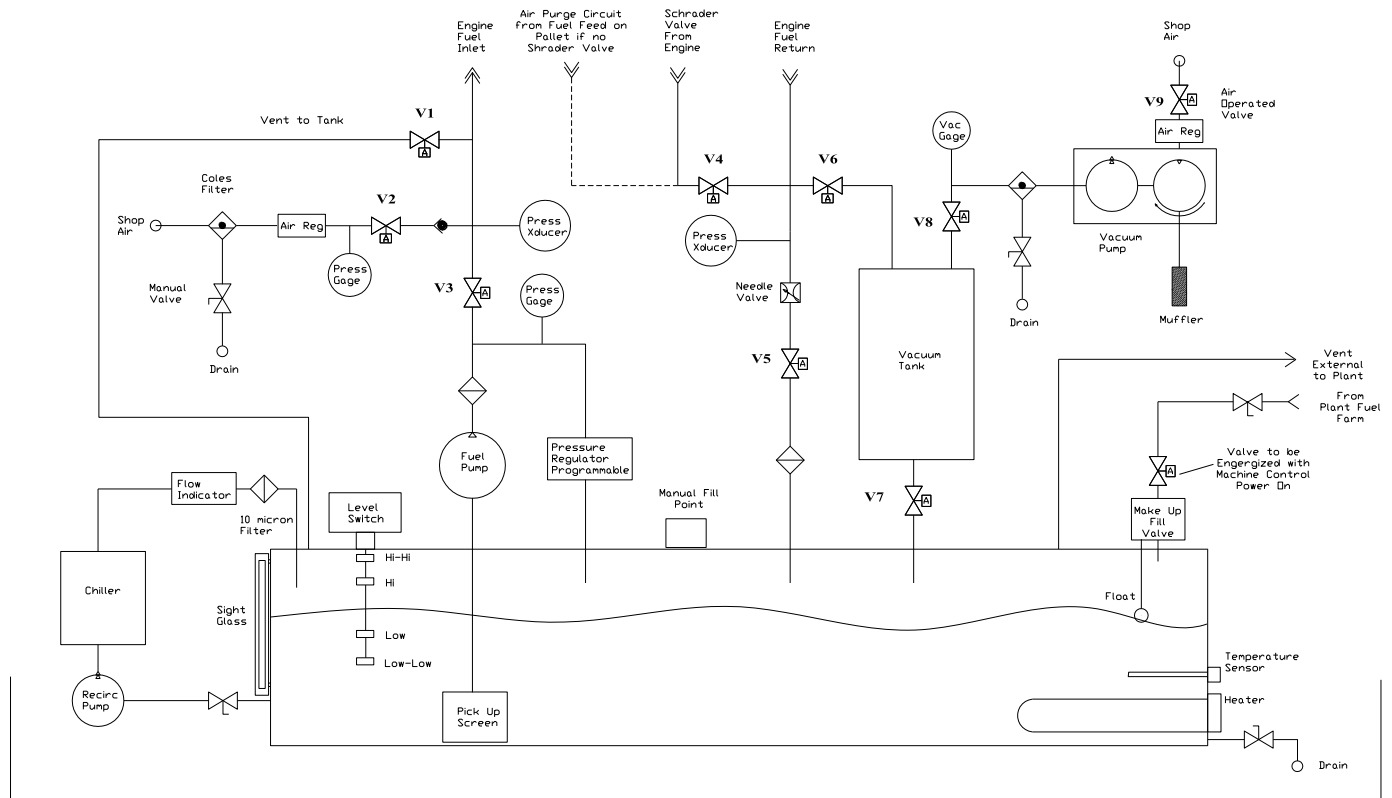

Figure 14: Diesel Fuel System Concept Drawing (Reference Only)



DIESEL FUEL SYSTEM LOGIC STATE CHART										
	V1	V2	V3	V4	V5	V6	V7	V8	V9	
AIR LEAK TEST FILL	C	O	C	O	C	C	X	X	C	Pressurize system (V2 Open) until pressure transducers show equal and stable pressure. Then hold for some time before closing V2. All valves must be in correct state before V2 opens.
AIR LEAK TEST	C	C	C	O	C	C	X	X	C	After closing V2 monitor pressure at transducers for some period of time and compare values to stored limits. If test fails indicate system fault and do not allow fuel pump to energize.
AIR LEAK TEST VENT	O	C	C	O	O	O	O	C	C	Monitor pressure transducers and allow sufficient time for system pressure to drop to zero.
FUEL PRIME	C	C	O	O	O	C	O	C	C	All valves must be in correct state before fuel pump is turned on. Turn on fuel pump, monitor pressure transducers and insure pressure reaches required window with in some time period and stays there. If pressure is not in the window during time period or is out of the window for some time period. Turn off pump and indicate fault.
RECIRCULATE	C	C	O	C	O	C	O	C	C	After closing V4 allow time for system pressure to stabilize. Monitor pressure transducers, insure pressures are with in windows for some time period. If pressures never stabilize with in windows after time period, turn off pump and indicate system fault.
HIGH PRESSURE RAIL LEAK TEST	C	C	O	C	O	C	O	C	C	High pressure fuel pump should be ready for engine cold motoring and priming of fuel rail. Use approved test sequence for operation of engine pressure control devices and monitoring of fuel rail high pressure during this leak test.
BLOW DOWN	C	O	C	O _T	O	C	O	C	C	Engine rotation or motoring shall be stopped. All valves must be in correct state before V2 opens. Keep V2 open for some period of time. During this period close and open V4 some number of cycles.
VACUUM EVACUATE	O _T	C	C	O _T	C	O	C	O	O	All valves must be in correct state before V9 opens. Open V9 and allow vacuum to be applied to the system for some time period. During this period close and open V1 some number of cycles to vacuum pulse the system. Occasionally during this period open and close V4.
PURGE VACUUM TANK	C	O	C	O	C	O	O	C	C	All valves must be in correct state before V2 opens. Open V2 for a period of time to purge the vacuum tank.

C = CLOSED, O = OPEN, X = DON'T CARE, O_T = STATE WILL TOGGLE DURING SEQUENCE STEP, C_T = STATE WILL TOGGLE DURING SEQUENCE STEP

Figure 15: Diesel Fuel System Logic State Chart (Reference Only)

3.3.2.9 Engine Drive System

- The drive system shall be all in-line with no gearbox or belt.
- The driveline unit shall have a position encoder. Use the output of encoder as an external clock input to the test system. Sample data on an event driven, external clock basis. Engine position is to be synchronized and data sampling triggered by the #1 cylinder top dead center (TDC) event.
- The driveline encoder shall have at least 4096 pulses per revolution. The software shall then be able to divide down the sample rate for each test individually.
- The driveline unit shall be engineered for 2500 RPM operation. The drive speed and ramp rates will be test computer controlled and variable from 0 RPM to 2500 RPM.

3.3.2.10 Engine Drive Unit Sizing Requirements

- The equipment supplier shall spin the engine on a mapping stand and collect torque, speed and time data throughout a typical test cycle taking special note of the breakaway event.
- Based on the data, the drive system shall be sized based on the following criteria:
 - Continuous/rated torque shall be at least 50 % of largest measured torque.
 - Maximum torque rating shall be at least 25 % greater than the largest measured torque.
 - Maximum torque shall be available up to 2000 RPM.
 - Acceleration capability shall be at least 30 revolutions/sec² under engine load across the entire speed range (0 to 2500 RPM). The engine inertia and the drive unit inertia and frictional forces shall be considered as factors that may influence acceleration capability.
 - Speed control accuracy across the entire range (0 to 2500 RPM) shall be 0.5 % of commanded speed or better under engine load.
 - Speed control repeatability across the entire range (0 to 2500 RPM) shall be 0.1 % of commanded speed or better under engine load.
 - The load duty cycle shall not exceed the maximum drive system duty cycle.
 - For diesel applications, size the drive to dynamically brake and shut down the engine if it starts to diesel on its own.

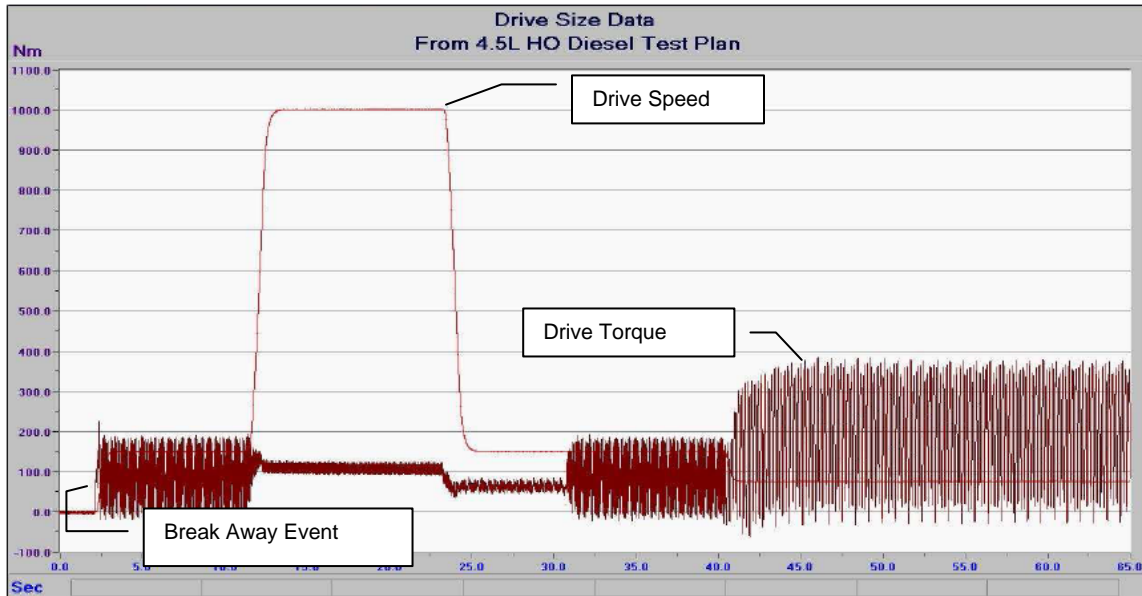

Figure 16: Drive Unit Sizing - Torque & Speed verses Time (Reference Only)

Table 1: Calculation example to verify drive unit sizing

Criteria	Procedure
Verify the drive unit sizing requirements have been met.	Review the plot of speed and torque verses time and verify the criteria has been met.
1. Is $CRT \geq LMT/2$? YES / NO	Largest Measured Torque (LMT): _____ Nm
2. Is $MTR \geq 1.25 * LMT$? YES / NO	Continuous Rated Torque (CRT): _____ Nm
3. Is $HS \geq 2000$ RPM? YES / NO	Maximum Torque Rating (MTR): _____ Nm
4. Is $RT \leq 2.2$ sec? YES / NO	Highest Speed (HS) at MTR : _____ RPM
5. Is $\sigma\text{-speed} \leq 0.75$ RPM? YES / NO	Clamp engine in manual mode, with intake and exhaust vents open, measure time to ramp drive from 0 - 2000 RPM.
6. Is $VAR \leq 0.15$ RPM? YES / NO	Ramp Time (RT) _____ sec
	In manual mode, set up engine for exhaust test (<i>Exhaust</i> = Closed, <i>Intake</i> = Open, <i>Supercharging</i> = On, <i>Speed</i> = 150 RPM). Start drive and acquire drive speed at 100 Hz sample rate for 10 seconds. Calculate the standard deviation of speed array ($\sigma\text{-speed}$).
	$\sigma\text{-speed}$ _____ RPM where $\sigma\text{-speed} = \sqrt{\frac{\sum(x-\bar{x})^2}{n-1}}$
	Repeat above data acquisition until 5 repetitions are stored. Calculate average speed for each repetition. Calculate the variance of the 5 average speeds.
	AvgSpd1 _____ RPM, AvgSpd2 _____ RPM, AvgSpd3 _____ RPM, AvgSpd4 _____ RPM, AvgSpd5 _____ RPM,
	VAR _____ RPM where $VAR = \frac{\sum(x-\bar{x})^2}{n-1}$

3.3.2.11 Required Transducer Calibration Fixtures

- The torque arm used for torque transducer calibration shall be mounted on the tooling side of the transducer, not the drive unit side. The locking pin shall be on the drive side so that resistance from the drive unit will not influence the calibration. The torque arm and the weights used for calibration must be designed so that the placement of the weights onto the arm does not present any safety or ergonomic hazard to the operator

(Reference 4.2.3). The design of the torque calibration fixture shall not allow an unbalanced condition (measurement variation) if the orientation of a nonsymmetrical subcomponent of the fixture is changed.

- All pressure transducers shall be capable of being calibrated on an individual basis by removing the transducer from its test stand fixture. Precision zero leak quick disconnects, see Reference 4.2.2, shall be provided at each transducer to provide easy removal and installation of the transducer during calibration.
- Sealing fixtures shall be provided for leak testing of the intake and exhaust port probe seals and blocking valves. The equipment supplier shall provide a single detail to clamp to each exhaust bank with a sealing surface similar to the cylinder head and each intake port with a sealing surface similar to the throttle body or intake manifold. The design shall allow an inexperienced technician to mount the fixture in less than 5 minutes without tools. Each exhaust port and each intake port shall be isolated by a quick connect for connection to leak test equipment. Minimize the internal volume so pumping up the pressure calibrator is faster. These fixtures shall be used only to verify the sealing integrity of the intake and exhaust port probes. They are not intended for calibration purposes. However, the supplier shall provide a set of sealing fixtures along with the calibration fixtures.

3.3.3 Electrical Design

3.3.3.1 Failure of a single transducer shall be easily identified and isolated from the rest of the sensor channels.

3.3.3.2 Mean time to repair (MTTR) for replacement of electrical connectors and transducers shall take no longer than 10 minutes. Follow mechanical guidelines for MTTR specified in Reference 4.2.11.

3.3.3.3 All power supplies in the Test Instrumentation Cabinet shall be regulated and linear with internal voltage trim. Switching power supplies will not be accepted. This applies to engine sensor, engine control, transducer excitation, instrumentation amplification, and any power supplies that are used for data acquisition channels.

Linear power supplies designed for laboratory use may not have UL/CSA ratings. The equipment supplier shall provide appropriate input and output fusing. The equipment supplier shall perform a witness test to verify the electronic short circuit protection. For installations in Canada, the witness test will be performed as a part of the ESA inspection. The installation shall be touch-safe.

3.3.3.4 Engine control devices (i.e. PWM controlled devices, ignition coils, control solenoids, etc.), shall have an independent source of power, not to be shared with instrumentation power.

3.3.3.5 The station shall be constructed of industrial grade components and manufactured to Buyer Machinery and Equipment Standards.

3.3.3.6 All signal cables shall be shielded.

Reference 4.2.4, paragraph 8.2.7.2 (s), states:

The shield for shielded cables may be terminated separately from the equipment grounding conductors. Only one end of a shield shall be grounded unless specified otherwise by the equipment manufacturer.

- Test points shall be available for each electrical signal before and after each circuit component to easily connect a meter or oscilloscope probe. For example, the crank sensor signal from the engine shall have test points both before and after the signal-conditioning module. In addition, the Engine Control (paragraph 3.3.4.1.3) shall have test points for all input and output signals. All test points shall be identified, documented and labeled in the electrical drawings.
- The ignition coil power wiring (+12 Volts and common) must use 14 AWG shielded twisted pair wire cut to the same length (± 2 cm) for all ignition coils and test stands between the Ignition Power Supply and the Engine Ignition Coil.
- All devices shall be properly grounded.

Reference 4.2.4, particularly...

8.3.3 (s) Bonding to a Common Reference Potential

For the U.S.A., isolated equipment grounding conductors may be used for sensitive computer/electronic equipment provided the requirements of the NFPA 70 - NEC, Article 250, are complied with.

For Canada, the equipment supplier shall comply with the requirements of the Ontario Electrical Safety Code.

13.1.2 (s)

Conductors and cables shall be selected and applied per the manufacturer's specifications. Careful consideration shall be given to the environmental conditions on or about the equipment, particularly where coolants, oil, fluids, welding, or heat are encountered.

If a foil shield is used for multiconductor shielded cables, it shall provide a continuous ground wire. The shields and ground wire shall be covered with an oil and moisture resistant jacket.

- All signals (transducers, sensors, Engine Control, I/O, etc.) shall be shielded. All grounding and shielding shall be shown on the electrical drawings.

Reference 4.2.4, particularly...

8.2.7.2 (s)

The shield for shielded cables may be terminated separately from the equipment grounding conductors. Only one end of a shield shall be grounded unless specified otherwise by the equipment manufacturer.

14.1.1.5 (s)

Where connection from a wire shield or ground wire to both connector pin and the cable clamp is indicated, the shield shall be connected directly to the pin and the pin connected to the cable clamp by stranded hookup wire. Connection to the clamp shall be with a lug.

- Where signal wires break out from shielded cabling, the unshielded signal wire length shall not exceed 50 mm. The exposed shield wire shall have heat shrink tubing to cover exposed areas between the exit from the casing and the termination at the ground buss.
- The maximum distance between the signal input terminals and the shield ground buss shall not exceed 50 mm.
- Shield drain wires shall be continuous from the field side connection to the signal conditioning input. If a quick connector is used, then the shield shall be carried through a pin and not through the case of the connector.
- Each system (engine sensors, engine control devices, instrumentation, main panel, test PC), shall have independent grounding planes that can easily be isolated from the rest of the systems for troubleshooting signal noise issues.
- Grounding for electrical and machine details shall be clearly documented in the electrical drawings. All ground connections (electrical and mechanical) shall be clearly labeled according to the electrical naming conventions for wires.
- Ground planes shall be made of Copper and provide low impedance bonding for any given system.

3.3.3.7 Test Transducer and Test Sensor Considerations

The equipment supplier is responsible for selecting an appropriate range for sensors and transducers that will maximize signal to noise ratio (SNR) over the expected range of variation of the information-carrying portion of the signal. Part proliferation, tolerances, and test step conditions such as engine RPM, engine design, test vent positions, and coil voltages will be major contributors to this variation.

- The appropriate SNR for each transducer shall be defined in writing by the equipment supplier and approved by Buyer during design engineering.
- All transducers and sensors shall use at least 50 % of their full-scale range so that the best possible signal to noise ratio is obtained.
- The appropriate full scale range for sensors and transducers is defined as 133 % of the expected range of the measured signal (two thirds of full scale).
- Transducers and sensors shall be able to withstand, without damage, whatever the test subjects them to even though it may be outside the transducers or sensors full-scale range.
- Standard ranges shall be used where possible. Custom ranges shall be approved through the deviation process.



Table 2: Calculation example to verify transducer ranging

Criteria	Procedure
1. Is $STR \geq FSR$? YES/NO	Overlay the channel curves and record the highest observed overlay range (include expected defect readings):
2. Is $OR \geq 0.5 * FSR$? YES/NO	Overlay Range (OR) _____ units Full Scale Range (FSR) = $OR * 1.33$
3. Is $SNR_{observed} \geq SNR_{design}$? YES/NO	FSR = _____ units Selected Transducer Range (STR) _____ units Approved SNR from design engineering phase (SNR_{design}) _____ Approximated Noise observed on signal (AN) _____ units Observed Signal Range (OSR) _____ units $SNR_{observed} = OSR/AN =$ _____

The number of transducers and sensors required will be driven by the available sensing positions, the level of build when the engine enters the test stand, and by test conditions. Generally, an exhaust signal will have a very high SNR and all exhaust ports will be accessible, so one transducer per port is expected. In order to meet the SNR requirement defined above, it is generally necessary to provide two oil pressure transducers, one to support the overall oil pressure measurement, and one to support the dynamic component of the oil pressure measurement.

Reference 4.2.2 Engine Test Approved Components List (CL-M-EngineTestACL) details additional requirements relative to component selection.

3.3.3.7.1 Exhaust Pressure Transducer

The exhaust waveform will generally contain the most information and typically has a very high SNR because of the high pressures developed during the test. There shall be one exhaust pressure transducer per cylinder, when the ports are accessible.

3.3.3.7.2 Ignition Sensor

When permitted by engine design, the preferred method to measure ignition events is through a direct measurement of coil performance using precision shunts. If a direct measurement cannot be made, then the Ignition sensor is a variable reluctance sensor; there shall be one shunt/sensor per engine coil.

3.3.3.7.3 Intake Pressure Transducer

The intake waveform is generally a composite of all intake port positions when the intake manifold is installed at cold test. A minimum of one intake transducer per port is required. If this causes difficulty with obtaining an acceptable SNR for all test conditions, then two intake vacuum transducers per port shall be provided (see discussion in 3.3.3.7). The equipment supplier shall request a deviation to use less than two intake transducers for composite waveforms.

3.3.3.7.4 Noise Vibration Harshness Transducer

There shall be one (1) block sensor. There shall be one (1) sensor per head (same orientation as piston travel). The probe design shall not resonate within the normal engine frequency ranges (crank, cam, valves, sprockets, gears, etc.).

3.3.3.7.5 Oil Pressure Transducer

The oil pressure tests take measurements first at high engine RPM to capture oil relief pressure related defects and then at low engine RPM to capture oil gallery pressure related defects. Since the oil pump will generally behave very differently at these different RPM ranges, it is sometimes difficult to achieve the necessary SNR ratios without resorting to multiple transducers. In order to meet the SNR requirement in 3.3.3.7, two types of oil pressure transducers shall be provided, one to support the overall oil pressure measurement and one to support the dynamic component of the oil pressure measurement. The overall oil pressure measurement is a traditional pressure transducer. Range this transducer for both the high- speed and the low-speed oil pressure tests. The dynamic oil pressure measurement utilizes a transducer that responds only to changes in pressure, effectively eliminating the DC component in the signal that represents the average oil pressure.

3.3.3.7.6 Oil Temperature Sensor

If the engine design permits, the oil temperature sensor shall be an infrared temperature transmitter targeted at the engine oil filter. When required by engine design, the oil temperature sensor shall be an RTD, fitted to a plunger mechanism that draws oil across the RTD through the oil pressure fitting, and then pushes the same oil back into the engine after sampling is complete. The method for measuring oil temperature shall not add cycle time to the machine.

3.3.3.7.7 Torque Transducer

The torque transducer shall utilize an in line rotary torque disk. The range of the torque transducer shall be optimized to comprehend both the low torque range expected for break away from zero RPM and the high torque range expected during ramp to high speed from zero RPM. The maximum torque during this ramp will be influenced by the mass of the flywheel, and the ramp rate the drive is set for, so engine proliferation and test plan modifications shall be considered when selecting the range of the torque transducer. Torque measurements are relative to the engine, not the drive unit. Torque is positive when the engine is under compression.

3.3.3.7.8 Diesel Fuel Rail Pressure Sensor (engine mounted)

For diesel engines, the engine mounted fuel pressure sensor shall be used for closed loop feedback to control all engine mounted fuel regulating valves. The fuel pressure sensor shall also be used to perform a fuel system leak test. The equipment supplier shall take both of these requirements into consideration to determine the appropriate SNR.

3.3.4 Test Instrumentation Cabinet Requirements

- The Test Instrumentation Cabinet shall control all data acquisition, test conditions, rerun strategy, and buffer data to disk for the Host System. All test data processing and calculating shall be done through the application software. There shall be no board level pre-processing (with the exception of continuous NVH tests).
- At least four receptacles shall be available from a power strip inside the cabinet.
- If the computer network goes down, when the network is fixed then all connections shall be automatically restored and the whole system automatically restored with no manual intervention.
- The Test equipment enclosure shall comply with Reference 4.2.8.
- Uninterruptible power supplies (UPS) are required for all computers and Ethernet switches.

3.3.4.1 Hardware Requirements (Reference 4.2.2 below)

3.3.4.1.1 Data Acquisition Hardware

- If a custom synchronization card is used, then the hardware shall have detailed documentation and be free of patent or licensing so that Buyer may reproduce it at a later date. All software / firmware shall be documented and downloadable to the board via the test computer.
- There shall be at least 20 % spare data input channels, hardwired from signal conditioning module to computer, and software selectable by Buyer engineer.
- The data analysis computer and processor must be the fastest offered at time of quotation. The delivered data analysis computer and processor must be the fastest available at time of purchase, not to exceed supplier's original quotation cost.
- The data analysis computer shall be network (ethernet) capable with host upload / download abilities for programs and or test result data.
- All computer boards and electronics shall be commercially available items with the exception of one (1) custom synchronization card.
- The test area weather station shall provide uninterrupted data to each test stand. The hardware must be centrally located to all test stands.
- There shall be a diagnostic area weather station to facilitate quality system auditing.
- In the event of weather data interruption to a test stand, there must be a backup method to use last known data, for a pre-determined, software selectable, time duration.

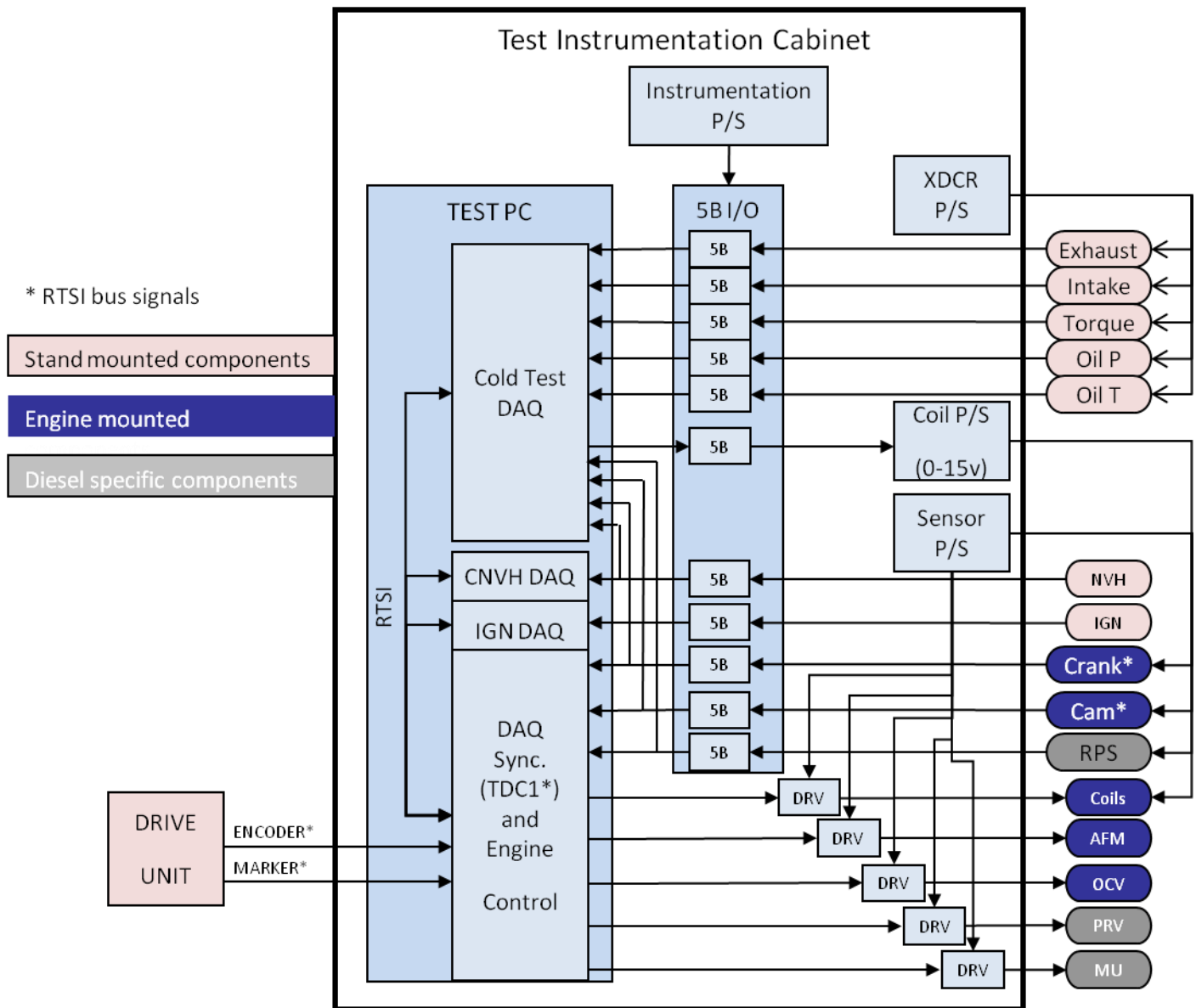

Figure 17: Test Station Data Acquisition & Control System Overview

3.3.4.1.2 Signal Conditioning

- All engine sensors (cam, crank, etc.) shall be isolated from the test system. In all cases, engine devices shall be isolated with a resistance of no less than 100,000 ohms (100k ohms).
- Do not use software or hardware filters to improve signal quality unless approved by Buyer (except for NVH, where hardware filters shall be used). If Buyer approves a software filter, then both the raw and the filtered waveform shall be stored with the test results. The filter criteria shall also be stored with the test record.

3.3.4.1.3 Engine Control

The supplier will provide hardware and software to support all engine control functions required during cold test. These functions will include ignition spark, closed loop cam phaser control, cylinder deactivation, closed loop diesel fuel pressure control, and others depending on the models and types of engines tested. This control method will interface with the engines under test in such a manner that does not stress or damage the engine and any of its components. This control method will allow easy test plan adjustment of key engine control parameters such as

ignition spark dwell-time, ignition spark timing, ignition coil voltage, cam phaser position, fuel rail pressure for diesel, etc. These control parameters shall be automatically selectable by engine model type and engine test sequence step. The supplier shall document and review with Buyer all control parameters used and all hardware interface parameters for Buyer approval during the design phase prior to final design approval. The engine control, as shown in Figure 17, may be integrated into the backplane of the Test PC, or it may be implemented as a separate single device that interfaces with the test software. Buyer prefers that the engine control be integrated directly into the backplane of the test PC using either an FPGA card or a combination of Counter/Timer cards so that maximum flexibility is maintained.

3.3.4.2 Software Requirements

3.3.4.2.1 Software copy protection shall be under the direct control of the plant/facility where the Test System is installed. No outside intervention/support shall be necessary to reinstall software on an immediate basis or to keep it active after an expiration period.

3.3.4.2.2 Weather station data and oil temperature data shall have limits and all statistical tools available.

3.3.4.2.3 Data Acquisition / PC Software

3.3.4.2.3.1 Operating System

- The test stand PC operating system shall comply with Reference 4.2.2 Engine Test Approved Components List (CL-M-EngineTestACL).

3.3.4.2.3.2 Overview

- Unless otherwise noted in the test definition, all individual tests shall be based on engine synchronous data recording, thus on an externally triggered measurement.
- The information about the rotational position of the engine is generated using the crank sensor and cam signal. (All engine signals shall first be isolated from the data acquisition system by the signal conditioning modules.)
- The crank signal is decoded into a 360° periodical reference signal. The test system combines the decoded crank signal with the cam signal creating a periodic 720° trigger signal.
- Data acquisition for all subsequent measuring channels uses the trigger signal. All data shall be triggered, collected and referenced to crankshaft position.
- The “top dead center” (TDC) position shall be referenced to the falling (or rising, on rare occasions) edge of the crank signal as specified by Buyer test engineer. Use of the cam signal shall determine if the engine is at TDC compression or TDC exhaust.
- In order to enable the measurements taken irrespective of engine speed, the incremental encoder output signal of the drive unit shall be processed by the synchronization electronics and transmitted to the AD-converter board.
- Clock signals of 4096, 2048, 1024 and 512 pulses per revolution shall be made available.
- Different clock inputs shall be software selectable. The input pulse rate of the drive unit encoder shall be 4096 pulses/revolution.
- Before data is collected, there shall be ample stabilization delay after the RPM is changed, engine control commands change, or the intake or exhaust port settings are changed. The stabilization delay features shall be both adaptive and fixed, software selectable in the test plan.
- Test performed in each phase shall be conducted in parallel.
- The test system, via operator intervention at the test station HMI, shall be able to retest an engine in Auto Mode or in Manual Mode whether the engine previously passed, failed or aborted.
- The software shall not allow the hard drives to get too full and crash.

3.3.4.2.3.3 Signal Processing/Analysis Requirements

- All waveforms shall be continuous. Do not rotate waveform data from the end of the array back to the beginning of the data array.
- The software application shall be capable to calculate results (test points) on a continuous waveform. Example: If torque minimum position for a cylinder can occur around 700° to 720° or around 0° to 30°, then sample the torque channel for an additional cylinder stroke. For an 8-cylinder engine, the sample period would be from 0° to 810° (instead of the normal 0° to 720°) and the limit set from 700° to 750°. This method typically applies to composite waveforms, like torque.



- The software application shall also be capable of entering wraparound window parameters. Example: If a waveform sampled from 0° to 720°, shows an event that can occur around 700° to 720° or around 0° to 50°, then set the limits from 700° to 50°. This method typically applies to isolated waveforms, like exhaust cylinder #1 position.
- The analysis algorithms shall have selectable choices to allow the test engineer to select evaluations for waveform events. Evaluations to include (for any channel of signal input):
 - Average
 - Standard Deviation
 - Maximum (peak)
 - Minimum (low)
 - Slopes
 - Transforms
 - Filters
 - Area under curve
 - Degrees of rotation between events: high, low, zero crossing, and above/below threshold
- Do not use software or hardware filters to improve signal quality unless approved by Buyer (except for NVH, where hardware filters shall be used). If Buyer approves a software filter, then both the raw and the filtered waveform shall be stored with the test results. The filter criteria shall also be stored with the test record.
- System ability for additional Buyer engineer created signal analysis algorithms to be incorporated into the test as part of the software.
- The software must support multiple test procedures and/or parameters that are loaded based on the engine model type.
- Data acquisition must support synchronized (triggered) collection of up to 20 signals in the same collection.
- Allow signal analysis processing to occur while another collection of signals is in progress in order to reduce cycle time.
- After reboot, the software shall automatically boot to the test software.
- All clocks (PLC, HMI, Test Station, Diagnostic Station, Host and Report) shall be synchronized to a common time server for time of day. This is needed to help with troubleshooting fault messages between the HMI and test station fault log, etc. The time server should be synchronized to NIST.
- The software shall have an Oscilloscope Display to show in pseudo real-time the continuous measurement of any of the channels simultaneously. There shall be y-axis scales for both actual input values (voltage, current, etc.) and calibrated values (Torque, Pressure, etc.).
- If the engine has both analog and digital crank signals then both signals shall be analyzed.
- Supplier shall provide a simple procedure to add a new limit set for a new engine type.
- Each PC or Server shall be self-supporting, if not connected to the network.
 - Example1: Server database management may not be triggered or run by a process on the Report PC.
 - Example2: The Server may not regularly trigger the Test Stand PCs daily hard drive cleanup.
- The test stand shall be able to switch between latest limit set on the server and another limit set in less than one minute.
- Save shunt calibration results along with the test data so that histogram and data analysis functionality is available. If shunt calibration fails, the results shall be stored using the EUN of the engine about to be tested. The overall test result shall show as an "Abort", rather than as "Fail"

3.3.4.2.3.4 Basic Functionality

- The data acquisition PC has many functions. Constant communication with the PLC for test status, start, specific test information data transfer. It also shall communicate with the Engine Control both for commanding device control routines and for reading data. It shall control all data acquisition, test conditions, rerun strategy, and data transfer to the host computer. All test data processing and calculating shall be done through the application software. There shall be no board level pre-processing (with the exception of continuous NVH tests).
- Any parameter that is compensated by weather or oil temperature shall have both the original and compensated waveforms and both the original and compensated results with limits for both. All statistical tools shall be available for both the original and compensated results. The original data is always required to make any changes to the gain or offset, etc. used to compute to the compensated value.
- On the Test Stand PCs, the previous engine test shall be displayed on the screen until the next engine test starts.
- Buyer plants and product engineering shall approve all test cycle operating parameters for speed, duration, intake, and exhaust pressures.
- When the Data Acquisition PC is turned on, it shall automatically login and be ready for Auto Cycle without intervention.
- The engine shall be rejected if the EUN structure is invalid.



- The test station HMI shall have the ability to mark an engine a reject at any time during the test cycle, to send the engine to the Diagnostic Loop. The test software must reject the engine as an operator reject and store this as part of the test record.

3.3.4.2.3.5 System Security

All test functions shall be password protected. There should be multiple levels of password protection. Basic level is for system reboot, and basic screen navigation. Second level is for all basic levels plus limit changes. High-level user is for all previous levels, plus program application changes, and other high level functionality. There shall be provisions for up to ten user passwords per level. In event of any changes, the system shall create a change log that records input when user selects "save changes". The date, time, and logged in user ID and comment field shall be saved. There shall also be an auto logoff of user privileges after "n" selectable minutes.

Accept / reject limits are to be password protected, and Buyer engineer altered.

3.3.4.2.3.6 Backup/Documentation Requirements

- See Reference 4.2.2 for system backup and restore requirements.
- Supplier shall provide a simple procedure to add a new limit set for a new engine type.
- Power supply outputs voltages also need to be qualified. The output voltages should be fed back into the data acquisition PC so the supplier's calibration verification screen can be used.

3.3.4.2.3.7 Flexibility

Multi language capable, during software start the language can be chosen. At this point, the language choices shall include (as a minimum): English, German, Portuguese and Spanish

Limit change function direct in the measurement software.

3.3.4.2.3.8 Multitasking

- The test stand software shall be able to multitask with numerous functions.
- For example, while the test system is running in automatic cycle, an operator shall be able to lookup locally stored engine data for data analysis while communicating with the host computer and automatically transferring engine data.
- All data for each test step shall be able to be collected in parallel.
- When parallel signals do not have the same minimum required sample rate, then the highest sample rate in the group shall be used for all channels.
- After the data is collected for a test step then the next test shall begin with the previous data being analyzed in parallel.
- Printing should not affect the test.
- *WebEx* and *PCAnywhere* should not affect the test.

3.3.4.2.3.9 Display Features

- Application screens can be modified flexible by the user. Navigation in the application should be everywhere the same.
- Screen setup shall be configured with only one main screen and all test result screens accessible with only one or two mouse clicks on the main screen.
- Where appropriate, all test screens shall have in the same position on the screen the EUN, Start Test Date and Time, Engine Type, Station Number, and Test number of total.
- Waveform colors for cylinders shall be common for all screens and printouts.
- Time shall be displayed in 24-hour military format.
- Date and time format shall be YYYY-MM-DD HH:MM:SS.
- Any result outside the limits shall be show in red on all test screens and all reports.
- All PCs shall have common screens. The Report PC, Diagnostic PC, and Test Stand PC shall all have common screens. Only items specific to a PC may be different. For example, the screen layout will include an area for graphs, controls, indicators, etc. The location of these areas will be consistent across all PCs. The content and definition of pushbuttons, graphs and indicators will be different depending on the application.
- Display all data in metric engineering units.
- Software shall have flexible zoom feature to enlarge any portion of the waveform.

- All PCs software shall have waveform overlay features to allow multiple engines waveforms to be displayed on the same graph. There shall be an associated table with the overlay graph with standard table features and the ability to remove specific waveforms from the overlay.
- The software shall have a screen showing the real time values of all channels simultaneously in both actual input values (voltage, current, etc.) and calibrated values (Torque, Pressure, etc.).
- Screen resolution shall be scalable to work at a minimum of 1024x768 to 1280x1024.

3.3.4.2.3.10 Creating New Test Plans / Versions

All new test plans and version changes shall be created by pull down menus with selectable inputs and functions. There shall not be any code writing to insert, delete, or modify the order of test segments. All changes including establishing new test plans, test segments, channels, and applying new algorithms shall all be by selection through pull down menus and dialog boxes.

3.3.4.2.3.11 Manual Mode Operation

The test software shall operate identically in both automatic and manual PLC selected modes. In manual mode a dialog box is used to input changes to the test routine that are desired. The default values will be the automatic mode set points. In manual mode, any speed, any test vent position, and data sample rate shall be changeable via keyboard input. Changes in manual mode via the keyboard input will be limited to those that do not violate safety or performance conditions of the test stand. In addition, phases and delays may be deleted, shortened or elongated. The changes shall be effective immediately (without reboot or compile time of greater than 30 seconds) and the stand shall execute the revised test automatically in manual mode once the start input is selected. The data shall be stored automatically as if it was a full automatic cycle.

The state of all I/O (Intake Vent, Oil Circuit Valve, etc.) shall be easily configurable (for example, a check box) for each part of the Automatic Test or Manual Mode.

Test software shall be capable of executing data acquisition and processing in a manual running mode. Speed and test selected are variable and controllable by Buyer engineer via keyboard / mouse.

3.3.4.2.3.12 Modifying Automatic Test Sequence

A test sequence editor for copying, enabling, and reordering of test segments shall exist for creating new test versions and sequences.

3.3.4.2.3.13 Calibration Software

Extensive calibration verification and calibration functionality shall be included. There are two intended uses of this calibration functionality, the first is for calibration verification, where results are displayed, but calibration values are not stored. The second use is for calibration adjustments, where results are displayed and calibration adjustments are stored.

- Software shall be capable to realize the n-point calibration for each sensor.
- Test stand software shall contain calibration screens with user settable set points and store and print utilities.
- The software shall be capable to input the gain and offset manually.
- The software shall have fields for each channel to enter the transducer serial number and the calibration unit serial number.
- The software shall automatically save and store all previous calibrations with; the Transducer Serial Number, Calibration Unit Number, Date, Time, Set Points, and Actual Readings for each set point, Gain, Offset and whether manually input.
- The software shall be able to recall and print previous calibrations.
- The user shall have the ability to select any previous calibration and set it as the current calibration.

The calibration screens shall show the real time value, running average over last second sampled and running span over the last second sampled. Calculate the average and span readings over the last second sampled at a 10 kHz rate. This helps for a better calibration by avoiding a calibration point with maximum electrical noise. Use the span to help determine the amount of noise on the channel.

For example, when the user selects the set PB, freeze the display of the average value and span for calibration verification. Prompt the user to store the calibration result. If the user ignores or cancels the store prompt, then the calibration is not changed. If the user acknowledges the store prompt, then the software uses the average reading for



calibration adjustments. This example process is for illustration purposes, the test supplier must meet the intent of this process in order to meet the specification requirements.

On the calibration screen (or calibration verification screen), provide:

- Sampling frequency (probably set at 1 MHz)
- Length of time (probably set at 30 seconds for plant periodic 4-month check and 120 seconds for checkout at supplier)
- Average value (acceptance criteria: +/- 0.2 % full scale of the transducer as read on the calibration verification screen)
- RMS value (for accelerometers and Microphone) (acceptance criteria: +/- 0.2 % full scale of the transducer as read on the calibration verification screen)
- Maximum (acceptance criteria: +0.5 % full scale of the transducer as read on the calibration verification screen)
- Minimum (acceptance criteria: -0.5 % full scale of the transducer as read on the calibration verification screen)
- Span (Maximum – Minimum)

3.3.4.2.4 Usability Features

3.3.4.2.4.1 Navigation

- The 'Esc' key shall be used to close any open window except the main window.
- Standard Microsoft Windows functions shall be available for selecting items from a list or table. Use mouse to select one item, Ctrl-mouse to select additional items, Shift-mouse to select a range, etc.
- The TAB key shall step through fields on the screen properly.
- The software shall be intuitive and designed for user efficiency minimizing the time required for a task. The software should be easy enough to use that training or help menus are rarely needed.
- The entire program shall be menu driven. With the exception of passwords, there shall not be any commands that have to be remembered, and then typed.

3.3.4.3 Test Cycle Diagram

- Example test sequences and a test cycle diagram are depicted below. The supplier is responsible for the entire station cycle time, adjusted for the design of the engine in the SOR, not just the times indicated in the sequences below.
- The gasoline test sequence depicted is for a V8 DOHC with Quad-Cam Phasing, Active Fuel Management™, eight (8) individual exhaust transducers and eight (8) individual intake transducers.
- The diesel test sequence depicted is for a V8 DOHC with two (2) exhaust transducers and two (2) intake transducer and fuel provided to lubricate the fuel pump.
- Actual test cycle operating parameters for speed, duration, intake, and exhaust pressures shall be approved by Buyer.

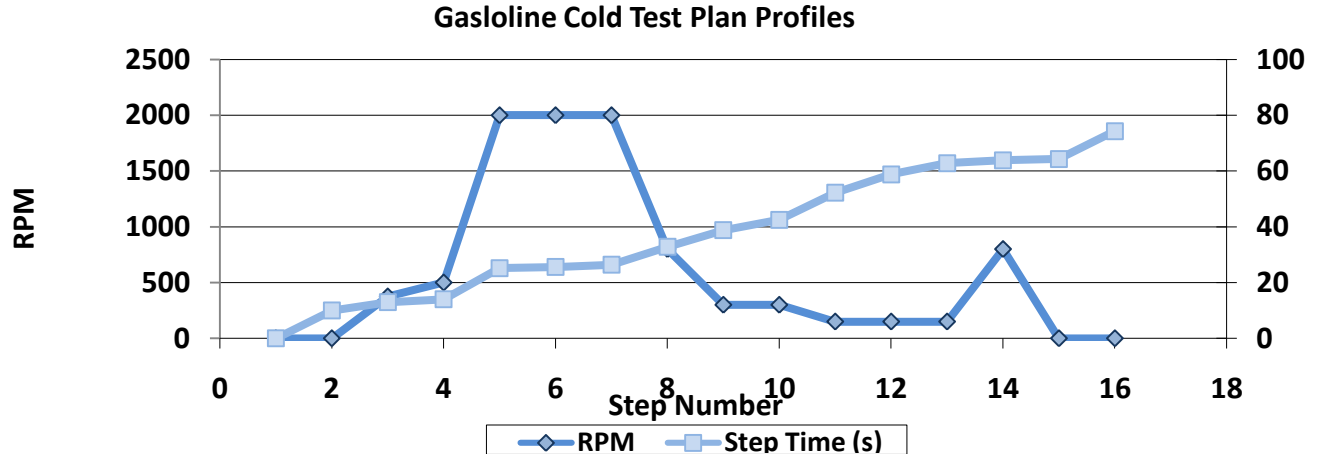

Figure 18: Gasoline Test Profiles (Reference Only)

Table 3: Gasoline Test Sequence Example (Reference Only)

Step	Step Name	Intake Vent	Exhaust Vent	Last RPM	RPM Ramp Rate	RPM	PLC Delay	Step Delay	Crank Rev's	Sample Dur	Step Dur	Test Dur	DAQ Card
1	Start of Test	Open	Open	0	250	0	0	0	0	1	0.0	0.0	Cold Test
2	Test Motions	Open	Open	0	250	0	0	10	0	0	10.0	10.0	
3	Break Away Torque	Open	Open	0	250	375	0.5	0	0	1	3.0	13.0	Cold Test
4	Cam/Crank/Reluctor Test	Open	Open	375	2000	500	0.5	0	2	0	1.0	14.0	Cold Test
5	Oil Relief/HS NVH Test	Open	Open	500	2000	2000	0.5	9.5	10	0	11.1	25.2	Cold Test
6	Ignition High Speed Test	Open	Open	2000	2000	2000	0	0	16	0	0.5	25.6	Ignition
7	Cam Phaser Sweep	Open	Open	2000	2000	2000	0.5	0	8	0	0.8	26.4	Cold Test
8	Active Fuel Management™	Open	Closed	2000	2000	800	0.5	4.5	8	0	6.4	32.8	Cold Test
9	Intake Test	Open	Closed	800	2000	300	0.5	4.5	2	0	6.1	38.8	Cold Test
10	Ignition Low Speed Test	Open	Open	300	2000	300	0.5	0	16	0	3.7	42.5	Ignition
11	Exhaust Test	Supercharge	Closed	300	2000	150	0.5	7.5	2	0	9.7	52.2	Cold Test
12	Torque Test	Open	Open	150	2000	150	0.5	4.5	2	0	6.6	58.8	Cold Test
13	Oil Gallery/LS NVH Test	Open	Open	150	2000	150	0	0	10	0	4.0	62.8	Cold Test
14	Cam Phaser Final Positioning	Open	Open	150	2000	800	0.5	0	2	0	1.1	63.9	Cold Test
15	Stop, Orient, Hold	Open	Open	800	2000	0	0	0	0	0	0.4	64.3	
16	End of Test Motions	Open	Open	0	2000	0	0	10	0	0	10.0	74.3	

Test speeds and test step positions may vary depending on individual engine requirements determined during engine mapping. Buyer approval required.

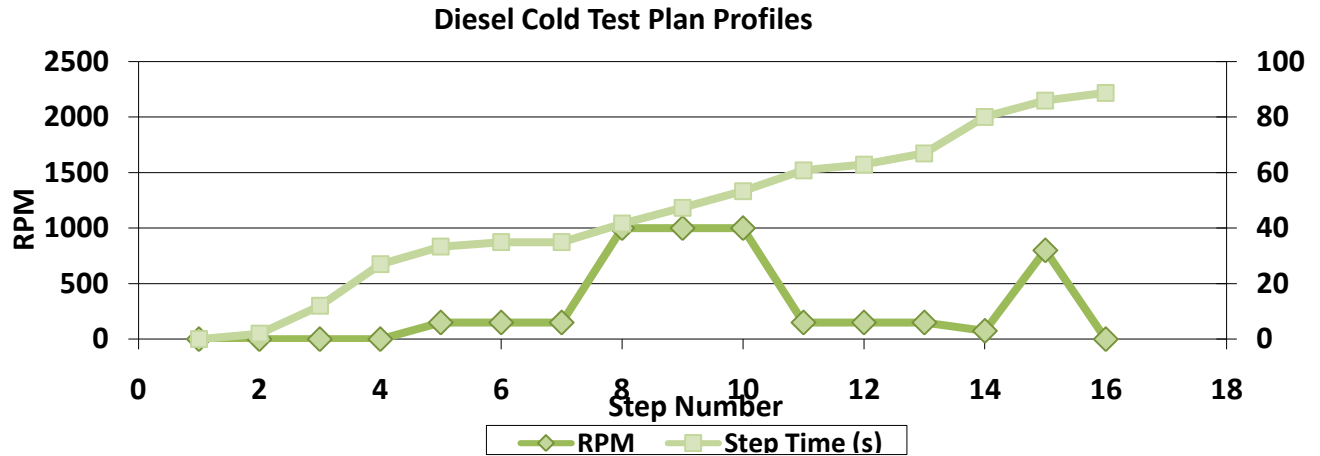

Figure 19: Diesel Test Profiles (Reference Only)

Table 4: Diesel Test Sequence Example (Reference Only)

Step	Step Name	Intake Vent	Exhaust Vent	Last RPM	RPM Ramp Rate	RPM	PLC Delay	Step Delay	Crank Rev's	Sample Dur	Step Dur	Test Dur
1	Start of Test	Open	Open	0	500	0	0	0	0	0	0.0	0.0
2	Fuel System Low Pressure LT	Open	Open	0	500	0	0	2	0	0	2.0	2.0
3	Test Motions	Open	Open	0	500	0	0	10	0	0	10.0	12.0
4	Fuel Prime	Open	Open	0	500	0	0	15	0	0	15.0	27.0
5	Break Away Torque	Open	Open	0	500	150	0.5	4.5	0	1	6.3	33.3
6	Cam/Crank/Reluctor Test	Open	Open	150	500	150	0	0	2	0	1.6	34.9
7	Fuel Abort	Open	Open	150	500	150	0	0	0	0	0.0	34.9
8	Ramp Order Analysis	Open	Open	150	500	1000	0.5	4.5	0	0	6.7	41.6
9	Oil Relief/HS NVH Test	Open	Open	1000	500	1000	0	5	10	0	5.7	47.3
10	Fuel System Dynamic	Open	Open	1000	500	1000	0	0	0	6	6.0	53.3
11	Intake Test	Close	Open	1000	1000	150	0.5	4.5	2	0	7.5	60.8
12	Torque Test	Open	Open	150	1000	150	0.5	0	2	0	2.1	62.9
13	Oil Gallery/LS NVH Test	Open	Open	150	1000	150	0	0	10	0	4.0	66.9
14	Exhaust Test	Supercharge	Close	150	1000	75	0.5	9.5	2	0	13.3	80.1
15	Fuel Hi Prs LT Start	Open	Open	75	1000	800	0.5	4.5	0	0	5.7	85.9
16	Stop, Orient, Hold	Open	Open	800	1000	0	0.5	1.5	0	0	2.8	88.7
17	Fuel LT Eval, Unclamp	Open	Open	0	1000	0	0	15	0	12.5	15.0	103.7
18	Fuel Evacuation/ Start of EOT Motions	Open	Open	0	1000	0	0	0	0	0	0.0	103.7
19	End of Test Motions	Open	Open	0	500	0	0	10	0	0	10.0	113.7

Test speeds and test step positions may vary depending on individual engine requirements determined during engine mapping. Buyer approval required.

3.3.4.4 Test Step Definitions

The test steps and evaluations shall be configured as described in the Application Note (see section 4.2.20). Each should be capable of detecting typical engine anomalies, listed under paragraph 3.7.6.6, for the particular engine(s) to be tested.

3.3.4.5 Safety Abort Tests

- If readings are outside the limits, then the test shall immediately abort.
- Limits shall be unique and configurable for each test step.
- All statistical tools shall be available.
- The available options for abort condition shall include:
 - Abort and release (no auto retest), without dropping Auto Cycle. Consecutive abort counter shall drop Auto Cycle. PLC sees this as a Level 3 fault, unless consecutive preset is met, then Level 1
 - Abort and stop in station, immediately drop Auto Cycle and fault station. PLC sees this as a Level 1 fault.

3.3.4.5.1 Torque Safety Abort

If this step fails, then abort and release.



- Monitor torque peak minimum hold and peak maximum hold over the entire test step, allowing for different limits while drive speed is constant and while drive is ramping to different speed.
- Store all data collected up to the abort condition.
- Store results only, no waveform data.

3.3.4.5.2 NVH Safety Abort

If this step fails, then abort and release.

- Monitor NVH running average, peak minimum hold, and peak maximum hold over the entire test step.
- Store all results. Store the waveform in case of abort.

3.3.4.5.3 Oil Pressure Safety Abort

If this step fails then abort and release.

- Monitor oil pressure running average, peak minimum hold, and peak maximum hold over the entire test step.
- Store results only, no waveform data.

3.3.4.5.4 Diesel Fuel Pressure Safety Abort

If this step fails, then abort and stop in station.

- Monitor diesel fuel pressure for minimum and maximum safe pressures relative to engine speed during the entire test cycle.
- Monitor fuel rail pressure and supply pressure running averages, peak minimum holds, and peak maximum holds over the entire test step.
- Store all results. Store the waveform in case of abort.

3.3.4.5.5 Diesel Runaway Safety Abort

Continuously monitor the driveline and engine to detect if the engine starts to diesel. If this step fails, then abort (close off intake air and mechanically brake and stop the motor with the drive) and stop in station.

- Monitor torque channel for torque reversal over the entire test step,
- Monitor drive speed (derived from drive controller) verses engine speed (derived from crank signal) over the entire test step for excessive mismatch
- Store all results. Store the waveforms in case of abort.

3.3.4.6 Data Analysis

Data analysis tools as described in Section 3.6, page 49, shall be available locally at the test station. These same data analysis tools shall run concurrently with the Test Station Software and not impair station operation.

3.3.5 Additional Cold Test Types

3.3.5.1 Ignition Only Test

If a separate "Ignition Test" station is required due to engine design or process sequence, it shall conform to the same specifications described within this document. This would apply for both static and dynamic ignition testing. Probing and clamping requirements would be modified as needed to meet the requirements of the particular ignition test type selected. The supplier shall configure the equipment and test steps according to the application notes (see 4.2.20 and 4.2.21) provided as part of the SOR.

3.3.6 Test Station/Test System Interfacing

- After reboot, the software shall automatically boot to the test software and automatic mode if the PLC is in automatic.
- The test stand, via operator intervention at the test station HMI, shall be able to re-run an engine test in Auto or Manual Modes whether the engine previously passed, failed or aborted.
- The communication between the pallet, test stand, and host computer shall be fully functional and confirmed by the test supplier. The test station shall be able to read and write to the pallet RF-tag and transfer data to the host computer. The equipment supplier shall supply an error (fault) and reject code log file.
- There shall be a method between the conveyor controller and the test stand(s) to disable the continuous aborts, for only one test. This method shall guarantee the engine will not leave the test area (go to the

conveyor unload station) under any circumstance. This is so mapping/special engines will complete the test without aborting.

- The HMI controls the test PC mode. When the HMI is in Auto mode or Manual mode then the test application follows.

3.3.7 Reject Management - In Station

A selectable Reject Management strategy shall be part of the test stand software. The software must be configured to handle two types of Reject Management. The first type is an automatic Retest. The second type is an automatic Recycle. If a test step is re-run then both the original and re-run waveform(s) and results shall be stored. At a minimum, the original waveform and the last two re-run waveforms shall be stored. All stored data shall be able to be recalled and analyzed with all statistical tools.

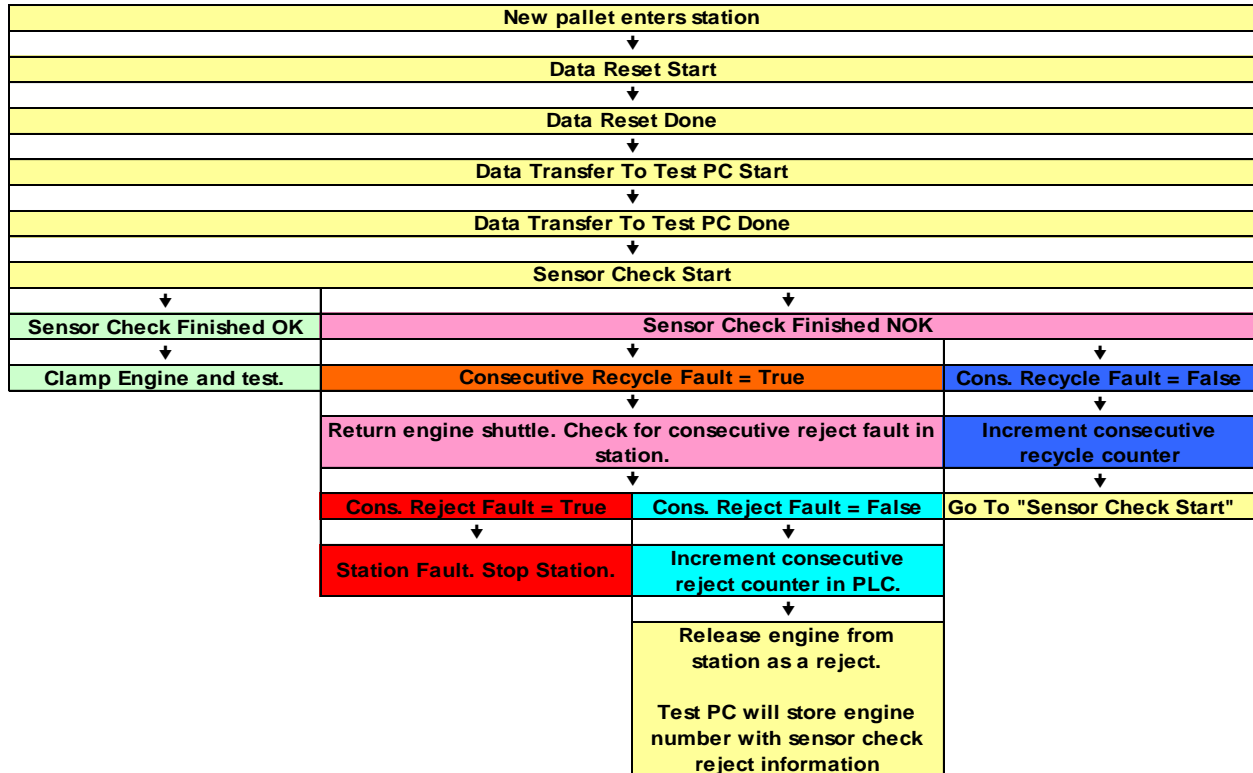

Figure 20: Retest Strategy (Reference Only) for Sensor Check (Shunt Calibration)

3.3.7.1 In Station Automatic Retest (Auto Retest)

The Auto Retest assumes that a mechanical probe, an electrical probe, or a sensor has failed to engage an engine component satisfactorily. The decision to trigger this kind of retest must allow for both PLC motion faults and for rejected waveform evaluations. This would therefore require that the test station probes must automatically retract and advance prior to continuing the test.

- The Auto Retest includes unclamping everything, returning all locators, and then re-locating and re-clamping. Cycle time shall be a consideration before deciding to unclamp everything. For example: If the station is advancing probes to clamp an engine for test, and a single motion (oil pressure probe, crank sensor probe, cam sensor probe, ignition probe) fails to show advanced, then immediately retry that single motion rather than unclamping everything. Critical clamping motions (engine clamps and stabilizers, exhaust and intake) should force all motions to retry.
- The “number” of Auto Retests must be programmable in the test setup.
- The “parameters” that will initiate an Auto Retest must be programmable in the test setup.
- After an Auto Retest on a prior step fails, subsequent parameter failures shall be programmable to enable or disable additional Auto Retests.

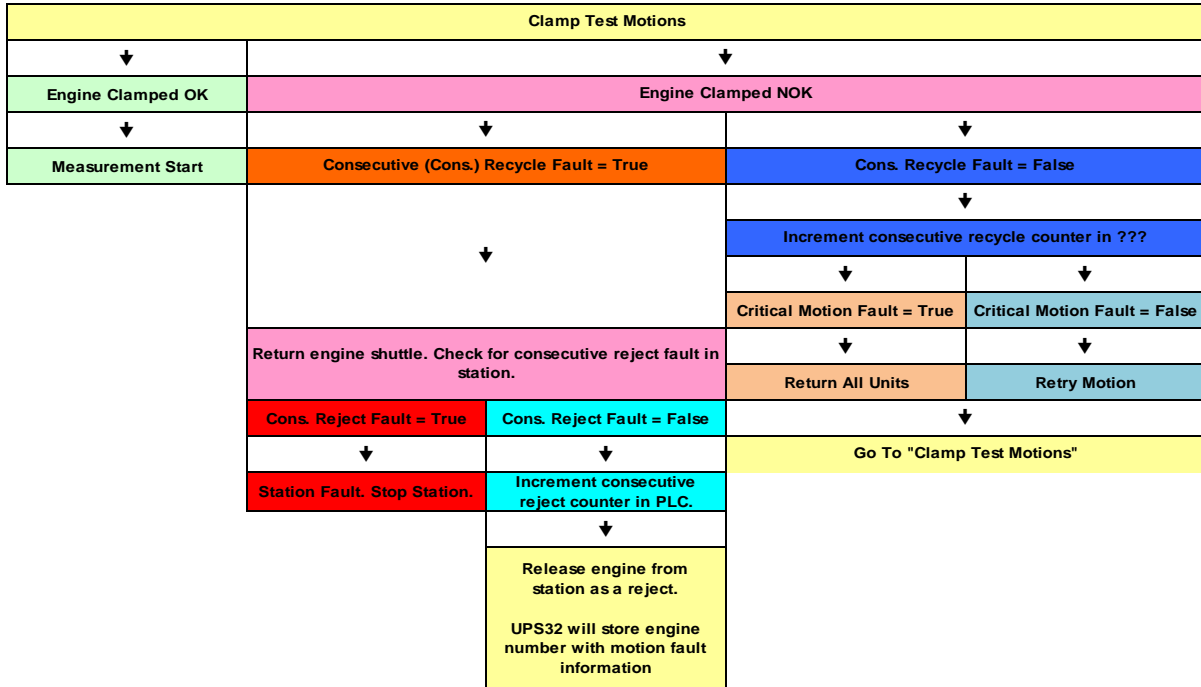

Figure 21: Retest Strategy (Reference Only) for Auto Retest

3.3.7.2 In Station Automatic Recycle (Auto Recycle)

The Auto Recycle assumes that an evaluation has failed due to insufficient engine stabilization time and that there is a good possibility that, given more stabilization time, the evaluation will pass the next time around. This would therefore require that the software will automatically jump to a predetermined (test evaluation dependent) segment of the test plan to allow for further engine stabilization prior to continuing the test.

The term “test evaluation dependent” refers to the program’s ability to handle multiple evaluation cases (Figure 22) to determine recycle criteria. An evaluation case shall consist of a single parameter or a logical combination of parameters determined by a test engineer. If the evaluation case returns a reject value, then the test engineer shall have the ability to enable recycle, disable recycle or abort the test for that specific evaluation case.

The strategy shall be flexible so that a segment may be rerun automatically after an evaluation case that requires an automatic recycle returns a reject value. Prior to the segment retest, a Buyer defined intermediate test step is completed. The original reject value shall be retained as part of the test record. The test step shall be Buyer engineer flexible for any test step condition, including but not limited to:

- RPM
- Duration
- Intake vent position
- Exhaust pressure vent position
- Number of reruns per segment

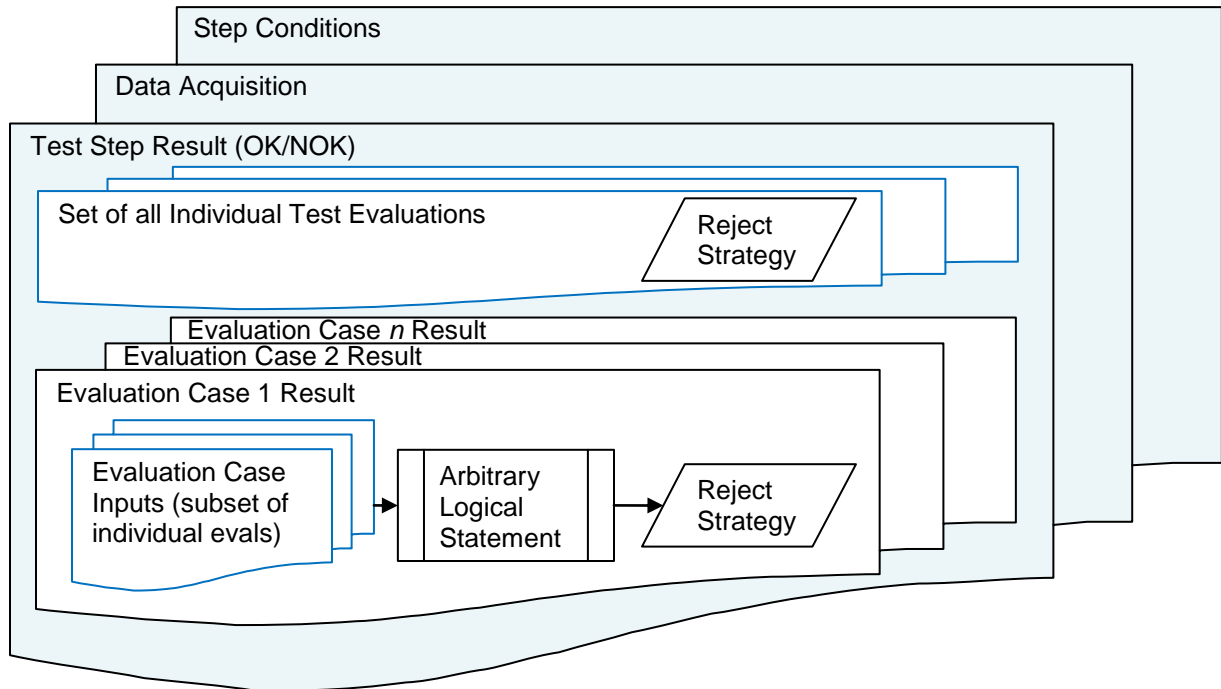

Figure 22: Test Segment with Evaluation Case Illustration

3.3.8 System Backup and Restore

All PCs except for server should have only one partition on the hard drive to make backup easier. The intent of having only one partition is to enable an unattended backup and restore of the entire hard drive during system backup. All PCs shall be configured for unattended back up and restore in accordance with Reference 4.2.2 and section 3.7.9.

3.4 DIAGNOSTIC STATION REQUIREMENTS

3.4.1 Diagnostic Stand Requirements (see overview in 3.2.2.1)

The Diagnostic PC (see 2.1.13) will communicate with the Conveyor Controller HMI (see 2.1.2) to meet the operational requirements in Reference 4.2.16.

- Each test record shall be able to store five diagnostic codes. Diagnostic Codes are three digit alpha-numeric strings. When a diagnostic code is entered at the Conveyor Controller HMI, the diagnostic code shall be automatically sent to the Cold Test Diagnostic PC and the diagnostic code stored with the most recent test of that engine.
- The diagnostic code entered on the Conveyor Controller HMI is for the current engine in the station, not the engine displayed on the Diagnostic Station PC.
- The Conveyor Controller shall be interlocked to the Cold Test Diagnostic PC. When an engine is selected or re-selected on the Conveyor Controller HMI, then the Cold Test Diagnostic Station PC shall automatically load the test results for that engine.
- If the Cold Test Diagnostic PC is turned off or if it faults, then the Conveyor Controller shall continue to operate in Auto Cycle without stopping Auto Cycle Mode. If the Conveyor Controller HMI is turned off or if it faults, then the Cold Test Diagnostic Station PC shall continue to operate without faulting.

3.4.2 Diagnostic Cabinet Requirements (see overview in 3.2.2.2)

3.4.2.1 Hardware Requirements

- The Diagnostic Equipment enclosure shall comply with Reference 4.2.8.
- A weather station shall be provided on the Diagnostic Station enclosure to use as a verification master with calibration certificates. This weather station shall be configured so that it is easy to swap with the test area weather station.



3.4.2.2 Software Requirements

- The maximum allowable time to display online engine data at the diagnostic station during regular production shall not exceed 5 seconds for the most recent test result of the engine in question. Additional (earlier) test reports shall be made available to the diagnostic station operator at a read rate not to exceed 5 seconds per additional test. This means that if an engine has been tested five times, then the most recent report must be available for analysis by the operator within 5 seconds of the request. It also means that all test results, in this example, shall be made available to the operator within 25 seconds (5 tests X 5 seconds per test) of the initial request. This requirement assumes that the engine travel time from the test stand to the diagnostic station has allowed enough time for the test record to be transferred to the host system.
- There shall be a pushbutton (PB) on the main screen to display a list of all tests for the currently displayed engine.
- The PgUp and PgDn keys shall scroll through all tests for the currently displayed engine. This shall work for the main screen and all sub screens.

3.4.3 System Backup and Restore

All PCs except for server should have only one partition on the hard drive to make backup easier. The intent of having only one partition is to enable an unattended backup and restore of the entire hard drive during system backup. All PCs shall be configured for unattended back up and restore in accordance with Reference 4.2.2 and section 3.7.9.

3.5 HOST SYSTEM REQUIREMENTS

3.5.1 Overview

- This section describes a real-time data collection and analysis host system. The system will utilize the hardware and Microsoft Windows operating system specified in Reference 4.2.2, with the most recent Service Pack installed and all critical Windows updates (same for all client PCs). The system will function according to the Client/Server architecture. The Server will be responsible for data collection and storage. The Client will run data analysis software. The server and client will be connected via an Ethernet network. The Ethernet managed switch, specified in Reference 4.2.2, shall have a minimum of four spare ports.
- Each PC or Server shall be self-sustaining, if not connected to the network. Example1: Server database management may not be triggered or run by a process on the Report PC. Example2: The Server may not regularly trigger the Test Stand PCs daily hard drive cleanup.
- All supplied software shall be compiled as a 32-bit application, at a minimum.
- All applications interacting with the database shall be compliant with the Microsoft Open Database Connectivity (ODBC) standard. All external applications interfacing with the database shall connect to the database using at least 32-bit ODBC drivers and be programmed using native ODBC function calls.
- Uninterruptible power supplies (UPS) are required for all computers and Ethernet switches.
- All applications shall be Windows common dialog compliant.
- The Host enclosure shall comply with Reference 4.2.8.
- After reboot, the host system and all available clients reconnect automatically.

3.5.2 Data Collection/Database Structure

The database will run on the Server. The database product deployed shall be relational and SQL based as specified in Reference 4.2.2. It shall have the following features:

3.5.2.1 ODBC Compliant

- Security features including creation of user accounts and the ability to grant user privileges.
- Support for a minimum of six concurrent users.
- Support for all required stored parameters, as defined in Data Analysis and Storage tables..
- Support for direct database access using Microsoft Office Professional, as specified in Reference 4.2.2, applications.
- The process of collecting, inserting and archiving the data should happen without need for user intervention. The application responsible for data collection should run on the server. The mechanism for data collection should be configurable with respect to its ability to “fetch” data from test stand or “receive” data from the test stand (configurable as a push or pull system).

- The test data streams should be captured to file for archive purposes. All data collected should be removed from the system and archived to Archive Media (see 2.1.1). Application will archive data for all parts regularly, but keep data online for time specified in the application.
- The software shall have an automatic incremental daily backup of test data from the current day's production to protect from data losses. Backup software provides an option to select incremental or full backup based on the plant and personnel requirements.
- The data collection software should also include a mechanism for inserting a shift number and a shift hour number (i.e. shift number 1, hour number 3). The shift specification routine should support up to 5 shifts per day and up to 16 hours per shift with individual support for odd length hours (i.e. 1 shift hour = 50 minutes). The odd length hour support is necessary for accurate calculation of target and actual:
 - For example, if a shift hour is non-productive for 20 minutes, due to a break for the operator, then the uptime calculation needs to exclude this time when calculating the target number of engines produced that hour.
 - Similarly, if a shift starts on the half hour, then only count production once the shift starts.

3.5.2.2 Version Control

The parameter data (application) for all test stands performing the same operation are equal and are stored at the server. Within the application, station related parameters are possible – they are stored multiple with a station suffix added. The parameter (application) database contains all the different versions created by the user and one or more work parameter sets, as needed. For editing the parameter and limits (any part of the application), the system uses only the work parameter set specified by the user. If the result of the development work is successful and should be stored, then the user creates a new “version” of the parameter dataset and identifies this by a version-ID.

- The version-ID must not be just a number. Allow the user to specify the ID.
- If the user specifies the same name multiple times, then the application shall maintain version history so the user is able to retrieve older versions.
- The version contains information about the user, time and date of creation and an info text (should contain the reason for the change) to trace back the parameter history. This information can be printed.
- The version-ID of the actual parameter set is stored in the engine data to allow access to all data valid for data acquisition and evaluation (all limits are stored in each dataset).
- The number of versions to keep must be configurable. When the limit is exceeded, the oldest version is removed. This should apply to the entire application, not just the parameters.
- For small changes (limit values, parameter values) the system must be able to distribute the new values automatically with a minimum of user input.

After starting the application, the test stations read the parameter data (application) from the set commanded by the user. If the user specified a set stored on the server and the server is not available, then the stand must continue with production using the local working set. When the server becomes available, the application downloads the new application data to the test stand without user intervention.

- Application data must be able to be copied from one site to another.
- Applications running different parameters but performing the same operation must be able to share the application data. This allows the greatest flexibility while providing the maximum protection.
- If an upgraded version of an underlying application is available, the system must be capable of installing the new version without user intervention.

This setup allows flexible parameter data handling. Under normal operating conditions, all test stands are using the newest (best) version. The server parameter setup can be processed at any PC running the server work parameter set (Normally the report PC). Changes are done in the work parameter set. After finishing this process, the work parameters are labeled as a new version, which can be, used at all other stands. In the case of a fault, the operator can easily step back to an older version. Versions can be created or deleted but not be changed. There shall be the option to label any older version as the newest version to allow returning to an older limit set if there are problems with the current limit set. The advantages of this version control compared to a log-file system are: easy switching to older versions store only major steps of the development, not each individual change full access of a engine dataset to all parameter (not only limits which are stored in the engine dataset)



The application shall automatically perform version checking on a regular basis (between cycles) and be configured in a way that does not interfere with production operation. In event of a discrepancy, the server shall log the discrepancy and the test stand number. The server shall also automatically copy the newest version to the test stand for use starting on the next test.

3.5.3 Local Parameter Database

If the server database is not accessible, then the test stand switches automatically to the local parameter data to run the application. A replication service compares and updates periodically the local parameter data (application) with the server to make sure that the local (application is complete) data is a complete copy of the server parameter.

The user cannot change parameter at the local database to prevent multiple data change at the different stations. This feature can be switched off manually for special purposes (e.g. commissioning without a server). Once the server has been restored, the test stand data shall be transferred to the server without disrupting production cycle time.

3.5.4 Acquisition

During the test cycle, all data are stored locally in the Local Data Area. A new dataset of engine data is created when an engine arrives in a test stand and the PLC transfers engine type, engine unit number (EUN) and pallet number to the test stand computer. A header is created containing all engine data, time stamp, test station, and program version information. Directly after execution of an individual test, the waveform, results, windows and limits are stored. Error messages and aborts (e.g. low oil pressure, no trigger, and emergency stop) are included in the dataset. Flags (included in the header) indicate total test result, the engine test status (e.g. new data – not transferred to the server) and that the test cycle is finished.

3.5.5 Data Transfer to Server

Write:

The application checks if there are new engine datasets stored at the Local Data Area. If this is true and the network connection to the server is OK, then the dataset is transferred to the server. The Local Data Area is set up as a variable sized buffer (programmable by engine count, megabytes of data, remaining hard disk space, etc.). If the limit is reached, then sufficient warning shall be provided to the operator before it becomes necessary to delete engine data. The operator shall then have the ability to move old data to an alternate storage media temporarily until the normal operation can be restored.. The warning shall be constantly repeated, so as not to be ignored, but shall not interfere with normal operation of the Test Station. If the operator fails to move data from the test station hard drive before the hard drive is full, then the test application should fault (Level 1) with a complete description of the reason for the fault including the necessary corrective action to clear the Level 1 fault.

Read:

The data sources "load from server", "load from local" or "load from Archive Media" (Archive Media on all PCs) can be selected to read back data. The default setting allows the "server" to have direct access to the server database. If the setting, "local," is used for commissioning, or if the network is inoperative, then the system uses the "Temporary Engine Data" area. The "load from Archive Media" setting is used to access data from the Archive Media automatically, as needed. The Archive Media Drive is always connected.

Archive:

The "Archive Manager", at the Host, automatically archives test data. The "Archive Manager" continuously transfers the "stale data" to an export data area. Data that meets archive criteria and that has not transferred to archive is "stale data". The archive criteria may be based on a fixed number of engines, a fixed timeframe, or it may be based on the size of the media because it is very difficult to predict the size of the data and number of tests per part. Once the archive criteria are met, the Archive Manager writes the export data area to Archive Media. If the transfer is successful, a flag to prevent multiple archiving marks the copied records.

An archive of time stamp information is included in the engine data set. This timestamp information can be used later as a reference to the Archive Media. After successful Archive Media writing, clear the temporary export data area.

The parameter data is stored on each Archive Media (backup of program parameters and limits). A message shall be displayed on both the Report PC and the Diagnostic PC when the Archive Media needs to be changed (user configurable parameter for disk free space). The operator is responsible to label the Archive Media properly with the archive time stamp and to load new Archive Media into the system.



3.5.6 Remote Diagnostic Support

- Remote system support/diagnostic capability shall be provided between the test supplier and the plant site.
- Ethernet shall serve as the physical connection between the test supplier and the plant site. Specifically, the connection will be from the test system network, through the plant IT network, out the firewall and to the Internet. If an alternate connection type is required due to specific plant requirements, then the test supplier shall propose an alternate solution through the deviation process.
- A web based collaboration tool (AT&T's WebMeeting, WebEx, or Microsoft Live Meeting, or SSL/VPN) shall be used as the remote support software mechanism. A support session will be conducted between the test supplier support PC and the appropriate test system PC (typically the Report PC, as preferred by the Buyer plant).
- All remote support sessions require approval, through a direct action by the responsible Buyer engineer. For example, the engineer may make or break a physical connection, or the engineer may have to provide a password in order to allow a remote session to start.
- The test supplier will need to install the appropriate web meeting plug-in software on their support PC.
- The test supplier will have access to the test stands via the use of PCAnywhere.
- The test supplier shall provide and install copies of PCAnywhere on all networked test system PCs.

3.5.7 Backup and Restore

All PCs except for server should have only one partition on the hard drive to make backup easier. The intent of having only one partition is to enable an unattended backup and restore of the entire hard drive during system backup. All PCs shall be configured for unattended backup and restore in accordance with Reference 4.2.2 and section 3.7.9.

3.6 REPORT CLIENT REQUIREMENTS

The Report Client enclosure shall comply with Reference 4.2.8.

3.6.1 Quality Gates (detailed separately on the system cost spreadsheet)

There must be built-in system detection of special cause quality or equipment problems. System will continuously monitor pass rate and test-rejects for statistically significant trends. Engineer will predetermine parameters to set alarms. Alarms should include e-mail, pager, and screen notification. The equipment supplier shall quote this as a separate line item in the system cost spreadsheet.

3.6.2 Limit Assistant (detailed separately on the system cost spreadsheet)

System server utility that computes recommended test limits based on engineer inputs. With the advent of increased quantity of parameters and new tests, a utility that assists the test engineer in limit setting and maintenance of limit parameters is needed. The equipment supplier shall quote this as a separate line item in the system cost spreadsheet.

3.6.3 Data Analysis

- All tables or lists shall sort (ascending or descending) by any column (mouse click on column header).
 - All tables and lists shall allow a sort by more than one column.
 - Column headers for all tables or lists shall indicate which column(s) is sorted and whether ascending or descending.
 - The default sort for all tables and lists shall be stored and retain the previous sort order the next time the table is accessed.
- All tables or lists shall allow mouse double click on any line to load that engine test result.
- All tables or lists shall automatically format column width to display all information in the column and header. The column width shall also be able to be adjusted manually with the mouse or mouse double clicked to auto format column width again.
- All screens shall have a print button and automatically print in Landscape Mode using the whole page.
- Engine test lists shall have a column (or indicator) for Pass/Fail with Pass indicated by the color green and fail indicated by the color red.
- All graphs shall have the ability to let the user set the x-axis and y-axis scales or auto scale. All graphs shall have the ability to auto scale the x and y axes independently as well as the ability to return to the original scaling.
- All graphs (both waveforms and SPC graphs) shall have the ability to zoom in by selecting a window on the graph.



- All graphs shall have two crosshairs available to drag with the mouse to their desired positions. The crosshairs shall keep their positions as the graph is zoomed (in or out). The screen shall display x and y-axis positions for each crosshair, values for x_2 minus x_1 , and values for y_2 minus y_1 , and slope $\frac{(y_2 - y_1)}{(x_2 - x_1)}$.
- All SPC graphs shall have the ability to graphically select a data point, or a range of data points, on the graph to load that data points test results. If a point on the graph represents more than one test result, then return a table of all tests represented by that point. This option shall also be available on the drop down menu from right clicking the data point.
- The user shall be able to edit parameters/limits in the data analysis screens, without having to navigate through several other screens first.
- All waveform graphs, SPC graphs, and tables and lists shall be exportable to an ASCII file for import to Microsoft Excel using the default parameters for import to Microsoft Excel.
- Any parameter shall have the same name on all screens, tables, lists, reports, etc.

3.6.4 Common Report Configuration Requirements

- All reports and utilities should be user configurable. Reports and utilities should be able to run in three modes:
 - Full interactive – This mode would prompt the user for all necessary information.
 - Semi interactive – This mode would prompt the user for configuration options
 - Fully Automatic – The user would only launch the pre-configured application.
 - Once report information entry is complete in full interactive mode, the user should be able to save the setup for future use.
- There shall be only one screen to select information for reporting. All values on select screen shall be retained as the default the next time the screen is accessed.
- A user shall be able to run any report without first accessing the select screen.
- The selection screen shall include the following options:
 - Select Database to use
 - Test Stands selectable (all, single or multiple possible)
 - Pallet Number (option to enable or disable)
 - Date/Time of Test range (option to enable or disable)
 - EUN range (option to enable or disable) - shall search for only one EUN if only one EUN field is entered
 - EUN search (option to enable or disable) that allows wildcard characters or accepts partial EUN's
 - First Time Test (option to enable or disable)
 - Select all tests, everything except the first test, select last N tests, or select first N tests
 - Select by shift
 - Select by day
 - Select engine type from list (all, single or multiple possible)
 - Select engine suffix from list (all, single or multiple possible)
 - Select all, only OK, only NOK, or only OK and NOK results.
 - Select any parameter or combination of parameters as a conditional statement from lists and apply operators from lists such as <, >, =, <=, >=, LIKE, TRUE, FALSE, AND, OR, etc. Order of operations shall be configurable with parentheses and/or brackets.
 - Select 'All Engine Tests' or 'Good Engine Tests' or 'User Verified Bad Engine Tests'
 - Select only engine tests with 'Engine Defect Information' (has enable check box)
- Reports should support relative date/time variables. For example, the user should be able specify that the report include data from some time increment less than the current time (i.e. -1 day, -5 minutes, -2 months, etc.).
- The user should be able to view a list of the configuration options (filtered data) that created the report, including, but not limited to:
 - Database selected
 - Table selected
 - Parameters selected
 - Date/time range selected; including relative date/time variables
 - Selection of a maximum number of rows to return
 - Filtering using relational operators such as <, >, =, <=, >=, and LIKE
 - Conditional tests



- Logical operators such as AND/OR
- Title and Subtitle lines
- Direction of output to screen or printer or file
- When outputting to the screen, the user will have the option of printing the entire report or only the data viewable on the screen
- Automatic or manual scaling of the x and y axis
- Reports should be able to read and write execution details to the registry. There should be user level variables that apply only the person logged into the system, as well as system wide variables that would apply to all users. The registry entries would hold items including, but not limited to, default values or last value used for dialog boxes, as well as database connection information.
- Data regarding parameter display issues such as formatting, scaling factors, column width, labels, outlier values and units of measurement should be stored in a centrally administrated location. All reports will reference this repository at the start of execution.
- All SPC graphs shall have an associated table with all data points and test result information. From the table any test result(s) can be removed from analysis. The graph and result data are then refreshed.
- Windows such as the 'Top 20 Rejects', Histogram, Scatter Plot, etc. shall be kept open when a test result is mouse double clicked for viewing. This allows for faster analyzing. Example: the 'Top 20 Rejects' are reviewed every day and each of the top test failures are reviewed, but to re-run the 'Top 20 Rejects' every time between viewing test results takes a long time. Use keyboard shortcut (such as ALT-TAB) to switch windows and the standard 'Window' toolbar dropdown menu to switch windows.
- Any requested database operation that takes more than 3 seconds shall have an active status indicator showing the application is 'working'. There also shall be a cancel button to cancel the operation. Standard reports and queries shall execute and display results to the operator within a reasonable amount of time. This means that a report that uses a week or less of production data shall execute and display within 10 seconds of the request. Likewise, a report that requires processing a month or quarter of data may take longer but shall not exceed 20 seconds. These rules apply for a fully populated database, for example, a one week snapshot of data from the earliest database records shall not take longer to process than a one week snapshot of data from the most recent records in the fully populated database.
- All PCs (Report, Diagnostic, and Test Stands) shall have complete SPC and report capability.
- Number enter fields shall be flexible. Example: -0.6 shall be able to be entered by typing (without quotes) "-0.6" or "-.6". Insert, backspace and delete shall be capable of modifying existing number fields.
- Software routines and applications shall be created or changed via menu driven dialog boxes.

3.6.5 Common Report Characteristics

- All graphs (Histogram graph, Trend Graph, scatter plot, etc.) shall show the limits as a dashed line on graph. The limits displayed shall be the currently active limits ((server or local) and (newest or working or labeled)) for the engine type of the currently displayed engine test record. The parameter limits shall be able to be edited from right mouse clicking on the graph and selecting from the drop down menu.
- All tables or lists of engine tests shall have columns for engine pass/fail, EUN, engine type, station number, and test start time. The 'Main Engine Select List', 'Diagnostic Station Engine List', and 'Current Engine List' shall also have columns for 'Test Number', 'Diagnostic Code 1', and 'Engine Defect' (right most column and fit as many characters as possible). Tables and lists relating to result data shall also have column(s) for the result data with the column header being the result name. Any other data relevant to a table or list shall also be included and all printouts of engine tables or engine lists or SPC graphs or reports shall include the 'Engine Select Information'.
- There shall be an option to print a full report for an engine test. The full report includes all graphs; all test results, the engine test list, and the engine test parameters. There shall be a select screen to select which pages are to be included in the full report. The selections shall default to the last selections by that user.
- All histograms shall display the class bars on the graph with different colors like the 'Top N Reject Graph'. The colors shall be selectable to represent the test stands, the engine types, or the suffixes.
- All waveform graphs shall have a check box to display vertical lines to represent intake valve and exhaust valve openings and closings. All waveform graphs shall also have a check box to display vertical lines for TDC and BDC for each cylinder.
- No printouts shall print the background colors. This conserves ink, saves time, and makes for easier reading.

3.6.6 Reports

3.6.6.1 Statistical

- All statistical calculations utilizing formulas shall be implemented using recognized industry standard methods (examples: **Handbook of Mathematical Functions, With Formulas, Graphs, and Mathematical Tables**, L.C. card 64-60036. Item 239, OpenMath, www.openmath.org, XML MathML, etc.).
- The standard methods chosen by the test supplier shall be fully documented with evidence indicating the software is compliant with the standard selected.
- Only one set of statistical tools shall be used for both long term and short-term statistical calculations.

3.6.6.2 Ad Hoc Report

- The Ad Hoc Report allows the user to view data in spreadsheet format.
- Parameters should be displayed from left to right in the order selected.
- The ad hoc report should also allow for export to an ASCII file.
- The report should return a small number of rows initially with the option to return more on demand.

3.6.6.2.1 Display Capabilities:

The output for the ad hoc report should include the following features:

- The report should display a count of the records returned and the current date/time.
- Specify units of measurement of parameters.
- Specify column width for individual columns on the report.
- Sort data in ascending or descending order.
- Apply column labels.
- Numeric and Date/Time formatting.
- Substitution of characters for null data.
- Resize columns interactively.

3.6.6.2.2 Configuration Options:

In addition, the Ad Hoc Report should be able to calculate statistics on the columns included in the report, individually or for all columns. Further, the user should have the option to display the column data or just the statistics. The statistics are listed below:

- Count of the number of data items in a column
- The minimum value for a column.
- The maximum value for a column.
- The sum of the values in a column.
- The mean of the values in a column.
- The range of the values in a column.
- The standard deviation of the values in a column
- $((3\sigma) / \text{mean})$ for the values in a column.
- $(\text{mean} + (3\sigma))$ for the values in a column.
- $(\text{mean} - (3\sigma))$ for the values in a column.

The ad hoc report should also have the ability to present an average of data points as a single point; similar to a non-graphical \bar{X} . The user should be able to specify the group size as well as the interval at which the sample will be taken.

3.6.6.3 Short Test Report

The Short Test Report shall be a 2 to 3 page long report when printed. All test results with limits shall be included in the report. The layout shall be user friendly and make functional sense. The main screen shall have button to print a Short Report for the engine currently displayed.

3.6.6.4 Top N Rejects

The user shall have the ability to specify if results outside the lower limit too low or the upper limit too high are in the same or different classes. The user shall have the ability to specify if the same parameter for different cylinders is in

the same or different classes. The 'Top N Rejects' Report shall have the results in both graph format (only top N rejects) and table/list format (all rejects). Selecting a class from either the graph or the table/list shall produce an Engine List of all Test Results in that class. There shall be a column with the evaluation result. The number of rejects in the list must be user settable.

3.6.6.5 Histogram

The histogram report should generate a normalized or standard bell curve superimposed over a histogram. The Y-axis is percent of total. The control limits should also be displayed on the chart.

3.6.6.5.1 Display Capabilities:

The histogram report should also display the following statistical information on the report:

- sample size
- mean
- standard deviation
- range
- lowest value
- highest value
- capability
- number in each frequency class
- number below specified low tolerance limit
- number above specified high tolerance limit
- number between specified tolerance limits
- A listing of the numeric ranges of the histogram classes.
- High, Low and Mean tolerance limits drawn on the chart as well as a textual specification of the tolerances.
- Display N frequency classes.

3.6.6.5.2 Configuration Options:

The histogram should also have the following configuration options:

- The option of specifying different process capability measurements, including CR, CP, CPK, 3σ and 4σ .
- Specify the number of histogram classes displayed.
- Specify the lower boundary of the maximum histogram class.
- Specify the upper boundary of the minimum histogram class.
- Specify the maximum and minimum values for the Y-axis.
- Specify the number of classes outside the limits. (2, 4, 6, 8, etc.)
- Option to scale the y-axis as counts instead of as a percent of total

3.6.6.6 Trend Graph

The graph report should plot the data points of up to eight parameters. If more than one parameter is displayed, the lines are displayed in different colors. The X-axis is selectable between sample number and date/time; the Y-axis is data values. Seeing trends as a function of Date and time is very useful for weather trends and daily shift trends. Seeing trends as a function of sample number is very useful when looking at trends with wide gaps between runs (allows contiguous display).

3.6.6.6.1 Display Capabilities:

The output should include the following features:

- Display 100 data points with the rest of the data scrollable.
- Display the high, low and a count of null values encountered.
- A color key for the graph lines.
- A crosshair mouse pointer can be used to pick out graph points and display the data value for that point as well as the date/time that the data was collected.
- Manual or automatic scaling of X and Y axis

3.6.6.6.2 Configuration Options:

The graph report should also allow for the following configuration options:

- Specify the maximum and minimum of the X-axis.
- Specify the maximum and minimum of the Y-axis.
- Specify a label for the X-axis.
- Specify a label for the Y-axis.
- Specify the size of the page frame (i.e. points displayed on screen without scrolling).

3.6.6.7 Scatter Plot

The scatter report can use either one or two parameters. If only one parameter is used, the data values for the parameter are plotted on the Y-axis against the date/time on the X-axis. If two parameters are selected, they should be plotted against each other. All data shall be available for use with the scatter plot. When the scatter plot is opened the previous X and Y-axis choices shall be the default.

The scatter plot shall do a least-squares-fit approximation on the data, and draw the line on the scatter plot, and display the slope and offset. This is used mainly for weather and oil pressure compensation.

3.6.6.7.1 Display Capabilities:

The output for the scatter plot should include the following features:

- Manual or automatic scaling of X and Y axis
- Group by Test Stand or Model and display as separate color on plot

3.6.6.7.2 Configuration Options:

The scatter plot should also allow for the following configuration options:

- Specify the maximum and minimum of the X-axis.
- Specify the maximum and minimum of the Y-axis.
- Specify a label for the X-axis.
- Specify a label for the Y-axis.

3.6.6.8 X Bar and R Chart

The X should be possible to plot up to 5000 sub-groups on one chart. The X bar and R report can produce four different variations.

3.6.6.8.1 Display Capabilities:

The output for X bar and R chart should include the following features:

- Display 100 data points with the rest of the data scrollable.
- Display the high, low and a count of null values encountered.
- Manual or automatic scaling of X and Y axis
- Display High, Low and Mean on both the X bar and Range charts.

3.6.6.8.2 Configuration Options:

- X bar and Range
- X bar and Moving Range
- X bar and Standard Deviation
- Moving X and Moving Range
- Display approximately 100 sub groups, the rest of the data should be scrollable.
- Specify the size of the page frame (i.e. points displayed on screen without scrolling).
- Specify the Y-axis label for the X bar graph
- Specify the Y-axis label for the Range graph
- Specify the group size
- Specify interval at which the sample will be taken.

3.6.6.9 Frequency Histogram

The Frequency Histogram report should allow the operator to improvise selections for classifications of data and produce a chart based on the frequency of occurrences of a unique parameter value. Classifications are displayed graphically as vertical bars representing the parameter value as a percentage of all data. The Frequency Histogram

may be configured to divide each classification into categories so that each classification bar is further divided based on another parameter value (i.e. test stand number) resulting in a stacked bar graph . The report should sort the X-axis first by frequency (high to low), then by classification. The report should function with both integer and character data types.

For example, the user may wish to investigate which test steps (classification) by model (category) are producing the most rejects. The process should be to build a custom engine list and then run the report. The label for the vertical bar would be the step name. The height of the bar would represent the percentage of engines from the engine list that rejected for that step. Subdivide each vertical bar to show the percent contribution of each model for the test step failures.

Typical selections might be:

- Overall result (Pass, Fail, Operator Abort, Test Stand Abort) by (station or model or recycle count or pallet or day or month or shift, selectable from list);
- Specific Step Result (Pass, Fail, Abort, Recycle) by result type (Opening, closing, max, min, avg, etc);
- Result Type (Exhaust Opening or Torque Average, selectable from list) by cylinder

3.6.6.9.1 Display Capabilities:

The output for Frequency Histogram should include the following features:

- Classification data value.
- A count of the data in classification.
- Percentage of data in classification.
- A color key for the stacked bar sections.

3.6.6.9.2 Configuration Options:

The Frequency Histogram should include the following configuration options:

- Display a label instead of the data value on the report output.
- Display a cumulative sum curve on the report output.
- Specify the number of classifications displayed.
- Grouping of similar classifications into a single classification for display.
- Suppression of classifications with no members.
- Option for Percent or count to be displayed on the Y-axis.
- Sorting of histogram classifications alphabetically; by classification total; by category within classification; in ascending or descending order.
- Pareto Chart

3.6.7 Utilities

3.6.7.1 Data Export to Microsoft Excel format

Database or engine lists, saved in excel spreadsheet format.

Single menu dialog box is used to select sort ranges:

- Starting date
- Ending date
- Model type(s)
- Stand(s)
- Engine number(s)
- Shift
- Pass / fail / first test / never pass / no retest or recycles / all tests
- Parameters or Phase data to export
- Export destination / file name

Output is to contain data in rows.

Columns to contain record header information and desired parameters.



3.6.7.2 Production Report

- First Time Pass (FTP): Only considered FTP if there were no individual retests (recycles) and no overall retests.
- First Time Accept (FTA) (includes FTP plus False Rejects): Report that shows engines which passed with no repair done. Include engine quantities, percentages, and engine list. The report shall be able to create an engine list with engines that retested and passed with no repair done. Use engine list of failed first time but eventually passed with no repair done to help determine if false rejects could be avoided by modifying the test plan or opening limits.
- For first time calculations, the term First Time refers only to green, previously untested engines. First time calculations shall exclude all other tests of that engine. For example, if a date range is selected for a first time calculation and if within that date range, there are instances where engines were run on a day prior to the start of the selected date range, then those previously tested engines shall not be counted. They are not to be considered in the first time totals for the selected date range.
- Overall Production (Good parts: includes defect free plus repaired): Report that shows engines which eventually passed, even if repaired. Include engine quantities, percentages, and engine list. The report shall be able to create a list of engines scrapped and a list of engines repaired including the last recorded repair code description (presumably the root cause for not passing the first test).

Cold Test Production Report

Report includes 300 engines that were First Time Tested from 2/19/03 to 2/19/03

General Information:

300 Engines Tested	73 Total Retests	All Stands	Stand 1	Stand 2	Stand 3
		24.30%	33.30%	22.70%	25.50%

Overall Production:

273	91.0% Good Parts (Defect Free + Repaired)
4	1.3% Suspect Parts (Failed engines that have not yet passed as of 2/19/03 2:39:00 PM)
23	7.7% Pulled Parts (Failed engines pulled off for heavy repair or further defect analysis)
0	0.0% Scrap Parts (Failed engines pulled off for tear-down that will never be reentered with the same EUN).

Overall First Time Accept:

253	84.30%	Defect Free Engines (First Time Pass + False Rejects)
------------	---------------	--

Overall First Time Capability:

First Time Capability by Family:

Count	Percent	Result of First Test	Retest & Pass	SIDI	PFI	IEM
260	86.7%	Passed (43 of 260 or 16.5% retested).	58.9% (43/73)	86.7% (260/300)	N/A	N/A
6	83.3%	Stand 1 Summary	100.0% (2/2)	83.3% (5/6)		
141	86.5%	Stand 2 Summary	56.3% (18/32)	86.5% (122/141)		
153	86.9%	Stand 3 Summary	59.0% (23/39)	86.9% (133/153)		
		(1 of 260 eventually passed)				
36	12.0%	Failed (29 of 36 or 80.6% retested).	39.7% (29/73)	12.0% (36/300)	N/A	N/A
6	16.7%	Stand 1 Summary		16.7% (1/6)		
141	12.1%	Stand 2 Summary	40.6% (13/32)	12.1% (17/141)		
153	11.8%	Stand 3 Summary	41.0% (16/39)	11.8% (18/153)		
		(12 of 36 eventually passed, 20 pulled)				
2	0.7%	Low Oil Pressure Abort (1 of 2 or 50.0% retested).		0.7% (2/300)	N/A	N/A
1	0.3%	Breakout Torque Abort (1 of 1 eventually passed)		0.3% (1/300)	N/A	N/A
1	0.3%	Cam and Crank Test Abort		0.3% (1/300)	N/A	N/A

Figure 23: Production Report Example (Reference Only)

3.6.7.3 Limit Manager

The Limit Manager utility is used to edit tolerances for the histogram, and control limits for the X bar and Range, X bar and Moving Range, X bar and Standard Deviation, and Moving X Moving Range charts. Each parameter should have its own limits for each chart (high, low and mean). The X bar and Range charts will require limits for both the X bar graph and the Range graph. The Limit Manager should also include the functionality to specify outlier values that are

not to be included in the calculation of limits or the report output. All tolerances, control limits and outlier values should be stored in a centrally administered repository.

3.6.7.4 Limit Calculator

The Limit Calculator utility is used to calculate control limits for X bar and Range, X bar and Moving Range, X bar and Standard Deviation, and Moving X Moving Range charts using the parameter values stored in the database. The new calculated limit should be inserted into the appropriate fields of the Limit Editor. The Limit Calculator should have the following configuration options:

- Issue a warning to the user if there is less than the optimal number of data points needed to calculate reliable limits.
- Option to not to update limits if a warning occurs.
- Specify the number of data points or the engine list to be used to calculate the limits.
- Use either the first or the last rows chronologically in the database.
- Calculate limits using industry standard formulas

3.6.7.5 SQL Processor

The SQL Processor allows the user to perform basic data manipulation tasks against the database. SQL code can be executed via an ASCII script file or entered at a command line. The SQL Processor requires commands for spooling the SQL code and the result set to a file.

3.6.7.6 Import Data

The Import utility allows the user to insert data from a comma delimited ASCII text file into the database. For example, Diagnostic Codes may need to be imported to a table in the database. Importing a test record from a file is beyond the scope of this feature.

3.6.7.7 Export Data

The Export utility allows the user export data from the database to a comma delimited ASCII file.

3.6.7.8 Database Cleanup

The Database Cleanup utility allows the user to remove data from the database by either deleting the data or by moving it to another table or database. Rows may be selected either by a date/time range or by specifying a count of rows for removal.

3.6.7.9 Editing Test Parameters

All test parameters shall be able to be edited by right mouse clicking the parameter or lower limit or upper limit and selecting 'Edit Parameter' from the drop down menu. The user shall have access rights to make any changes. The default limits and all engine type limits for that parameter shall be editable from the displayed dialog window. The cursor shall default to edit the limit for the currently displayed engine type.

There shall also be a Parameter Editor with a row for each parameter and columns for each engine type. New engine types can be created from this screen. Windows standard Cut/Copy/Paste/Delete/Insert/New/Select/etc. functions shall be available from menus and with mouse to manipulate engine type parameter sets and to manipulate individual or groups of limits.

3.6.7.10 User Verified Bad Engine Test

There shall be a check box for each engine test to manually mark an engine test as bad. The test may be bad because the engine was bad or a transducer was out of calibration, etc. This box is used to exclude tests from Statistical Analysis when analyzing limits etc. This box is not used to change the pass/fail status of an engine. The check box shall be active (settable/clearable) from the main engine test screen with the proper login security level. From any engine table/list, by right mouse clicking, the drop down menu shall have a choice to set/clear the 'Bad Engine Test' box for all engine tests selected in the engine table/list.

3.6.7.11 Re-Run Old Tests with New Limits

The software shall have the ability to re-run old engine tests using new limits. All of the engines in the 'Main Engine List' are re-ran with a new limit set and an engine list is returned showing which engines originally "passed and now



fail” and which engines originally “failed and now pass”. Manipulation of the original record is not possible by this function.

3.6.8 System Backup and Restore

All PCs except for server should have only one partition on the hard drive to make backup easier. The intent of having only one partition is to enable an unattended backup and restore of the entire hard drive during system backup. All PCs shall be configured for unattended backup and restore in accordance with Reference 4.2.2 and section 3.7.9.

3.7 ADDITIONAL REQUIREMENTS/DELIVERABLES

3.7.1 Specification Compliance

- The equipment shall comply with all Buyer applicable specifications. See *General Project Specifications (SP-G-General*, 4.2.12, for complete details).

3.7.2 Mapping (detailed separately on the system cost spreadsheet)

3.7.2.1 Provide a mapping rig and labor for the following required activities:

- Mapping to properly size components on the test stand (driveline sizing, transducer sizing, clamping requirements, etc.).
- Develop/demonstrate test steps that are engine design specific. For example, Active Fuel Management™
- Develop/demonstrate defect detection capabilities (see 3.7.6.6).

3.7.2.2 Option to continue defect mapping at Buyer site after equipment installation.

3.7.3 Calibration Equipment

- Provide all certified calibration equipment (traceable to NIST) required for equipment set-up and run-off (see 4.2.9 and 4.2.10). In addition, pricing shall be detailed separately on the system cost spreadsheet for Buyer to purchase the commercially available calibration equipment.
- Ignition Sensor alignment tool (described in 3.3.2.3) included as base equipment.
- Laser alignment fixture (described in 3.3.2.2.2) included as base equipment.
- All transducer calibration fixtures (described in 3.3.2.11) included as base equipment.

3.7.4 Training

- The equipment supplier shall quote performance based training for the test stations in compliance with the Training Specification for Manufacturing/Assembly Systems and Equipment (SP-G-Training), 4.2.13.
- The cost for training shall be documented in the “Supplier Training Summary Worksheet” as detailed in 4.2.13.
- The cost for training shall not be included in the equipment pricing.

3.7.5 Installation and Startup Support

- Reference the Installation Support and Startup Support requirements in the Statement of Requirements (SOR).
- The cost for support shall not be included in the equipment pricing.

3.7.6 Documentation

- All documentation shall be provided in an orderly and well organized manner. The use of binders, folders and other organization tools with proper labeling shall be used as appropriate.

3.7.6.1 Drawing Package

- A complete drawing package (e.g. mechanical, electrical) shall be provided per the requirements in the Global Manufacturing Drawing Specification Document (SP-G-Drawing), 4.2.14.
- In addition to these requirements, the drive system parameters shall be documented in the drawings.
- Two electronic and two hard copies of the drawings shall be provided. The hard copies shall be printed on 11”x17” (or A3 format depending on the plant site requirements), sheets and bound.

3.7.6.2 Technical Manuals

- Technical manuals shall be provided per the requirements in the Maintenance of Machinery Specification (SP-G-Maintenance), 4.2.15. Additionally, the manuals shall describe procedures for:
 - Calibration



- Screen display changes
- I/O assignment changes
- Test algorithm changes
- Test data channel and/or additions
- Configuration and programming of the test software, parameters, and limits
- The technical manuals shall be provided in both hard copy and electronic formats. The electronic format shall be editable by a Microsoft Office application.

3.7.6.3 Test Program

- The test supplier shall submit an annotated diagram and program listing of all data acquisition and test algorithms, test parameters, and limits for each test application on electronic media.
- In addition, the test program documentation shall contain:
 - Detailed description of the system architecture
 - Description of the test software directory and file structure
 - Error (fault) and diagnostic code descriptions

3.7.6.4 Software Licenses

- All software licenses shall be provided to the responsible Buyer (engineer or IS&S) contact at time of equipment delivery to the plant site. Proof must be provided that all software has been delivered to the Buyer contact.
- The supplier shall provide licensed copies of all software used by the system (commercial “off the shelf” and test supplier specific).
- Costs for individual and site licenses for the test supplier specific software shall be provided at the time of quotation.
- The supplier shall supply one software documentation package including all test supplier specific software licenses, including all digital media (CD, DVD, etc.) that is available with the software.

3.7.6.5 Calibration Certificates

- The supplier shall provide a hard copy of the calibration certificate for each measurement device including the transducers, accelerometers, microphones and validation/calibration equipment.
- The calibration certificates shall be supplied prior to the start of preliminary run-off.

3.7.6.6 Defect Mapping Report

- The supplier will be responsible to provide labor and testing time to build and demonstrate 10 defects selected by GM from the list below.
- The supplier shall quote time and material for additional mapping beyond the 10 required defects.
- The supplier shall provide a report demonstrating defect detection capability of each failure mode selected for mapping.
- The report shall state each parameter for each failure mode, a waveform showing the difference between good and bad, and the values of each failed test point.
- The defect mapping report shall be submitted and approved prior to the start of the preliminary run-off.

3.7.6.6.1 Oil System

Connecting Rod Bearing Shell missing or wrong location, all cylinder locations, rod side, cap side. Main Bearing Shell missing or wrong location, all cap locations, case side, cap side. Oil Hole blocked in block, crank, and head, Oil Hole oversized in tappet position, Defective Oil Pump, Oil Suction Pipe missing/blocked, Tappet missing, OCV not operating, Timing Chain Tensioner not operating, Oil Filter Assembly incorrect, Oil Filter Assembly blocked, Piston Squirter blocked, No Oil, cylinder deactivation inoperative, cylinder reactivation inoperative

3.7.6.6.2 Torque

Swarf on main bearings, rod bearings, and cam bearings, Tight Tappet, Tight Bearings, Piston/Ring damage, Foreign Material.



3.7.6.6.3 Intake/Exhaust

Timing advanced, timing retarded, wrong cam, cam out of specification, tappet soft, tappet hard, valve bent, valve seat damaged, intake leak vacuum pipe/line leak, cam roller missing, pushrod bent, pushrod mixed, AFM™ lifter inoperative.

3.7.6.6.4 Electrical

Faulty ignition coil assembly, coil spring missing, plug gap out of tolerance, plug isolator cracked, plug incorrect, crank sensor faulty, cam sensor faulty, OCV faulty, Crank Timing Ring out of specification, LOMA inoperative.

3.7.6.6.5 Diesel Fuel System

Faulty fuel pressure control components (rail pressure sensor, pressure regulating valve, metering valve), fuel leaks.

3.7.6.7 Quality Reports

- Quality data shall be provided for each run-off/acceptance test as described in the Machine and Assembly Run Off Specifications (SP-Q-MARO), 4.2.9 and the Measurement Systems Specification (SP-Q-MSS), 4.2.10. with the following clarifications:
 - qs-STAT will be utilized to conduct Type 1A studies. This study verifies the repeatability of the transducers. Data will be manually entered into qs-STAT on a separate PC.
 - qs-STAT will not be utilized to conduct Type 1 studies. This study verifies the repeatability of test measurements on the same engine. Since the engine characteristics change as testing proceeds (green engine vs. broken-in), the value and results of the Type 1 study require manual interpretation.
 - qs-STAT will not be utilized to conduct Type 2 and Type 3 studies. The Type 2 study verifies the repeatability of data on one stand with multiple engines. The Type 3 study verifies the repeatability of data from test stand to test stand with the same set of engines. For the same reasoning described for Type 1 studies, manual interpretation will be used to determine the results of these tests.
- The supplier shall conduct the Type 1A studies and provide the documentation prior to preliminary run-off.

3.7.7 Spare Parts Proposal

- A spare parts proposal shall be provided per the requirements in 4.2.15 and/or the SOR package. In addition to the recommended list, pricing shall be provided for the following items:
 - Seals
 - Electrical probes
 - Synchronization boards
- The supplier shall have spare parts available for a minimum of ten years commencing with start of production.

3.7.8 Preventive Maintenance Plan

A preventive maintenance plan shall be provided per the requirements in 4.2.15.

3.7.9 Disaster Recovery – System Backup and Restore Requirements

A disaster recovery procedure for each hard drive shall be documented and implemented prior to equipment run off at the equipment supplier's site. The documentation shall include detailed procedures to backup and restore hard drives automatically. The equipment supplier is responsible for maintaining current image files of all hard drives during system installation and debug. Buyer will assume responsibility for maintaining image files after the system has been run off at rate at the plant.

3.7.9.1 Backup and Restore of Server Hard Drives

There shall be two written procedures to restore the server.

- **Restoring the server with the same hardware:** The entire server (all hard drives and partitions) shall be backed up and restored using digital media. Provide for unattended recovery of the entire server after initiating the recovery sequence.
- **Restoring a server with different hardware:** This written procedure shall describe in detail how to install the Operating System and then all other software. In addition, there shall be a procedure to fill the database with the old test records from the backup media, and from the Test Stands, and from the Report PC. No duplicate test records in the server database.



3.7.9.2 Backup and Restore of Test Stand / Diagnostic / Report Hard Drives

There shall be a common procedure to backup and restore all PC Hard Drives except for the Server. The PC hard drives shall be backed up to a network hard drive. After installation of a new unformatted hard drive, booting from the portable media (USB drive) shall restore the PC hard drive. The restore program shall be capable of restoring to a hard drive of a different size.

3.7.9.3 Common Requirements for Backup and Restore

3.7.9.3.1 Network Connectivity

- The test PCs' network card device driver shall be pre-loaded, and the network card shall be configured and ready to be connected to the plant network.
- The network settings, such as PC name, Domain name, IP address, DNS address, and Wins address, of the test PCs shall be pre-configured according to settings provided by the Buyer site IT department.
- The equipment supplier shall verify with Buyer that the test PCs' operating system versions are compatible with the plant network relative to service packs and security patch levels.
- The test PCs shall have the Buyer approved anti-virus software installed with up-to-date virus definition files loaded at the time of site run-off. See Reference 4.2.2 for specific details.
- All PCs shall be loaded with the latest BIOS and software versions.

3.7.9.3.2 Backup and Restore Capability

- A well-documented step-by-step procedure shall be provided to backup and restore all test PC hard drives.
- The procedure shall be based on using a hard drive image on portable media for commercial "off the shelf" software and test supplier specific software and on portable media for the station/application specific files.
- In addition, provisions shall be made (as denoted below) to support a network based backup and restore system.

3.7.9.3.3 Commercial "off the shelf" and test supplier specific software

- A hard drive image shall be provided as the means of backup and restore.
- The test PCs shall be configured so that their hard drives can be imaged using the Buyer approved backup and restore software. See Reference 4.2.2 for specific details.
- The hard drive image shall be common for identical test PCs and shall NOT contain any station/application specific files.
- Bootable portable media shall be provided to initiate the restore process for network based backup and restore.

3.7.9.3.4 Station/application specific files

- All station/application specific files shall be organized in a single file folder named *C:\project*.
- The station/application specific files shall be copied to the *C:\project* directory. These files shall be copied in native format and not be zipped or compressed. Loading the station specific files into the *C:\project* folder on a hard drive with only the common hard drive image loaded shall make the test system functional and enable the test PC to be connected onto the plant network.
- Portable media (e.g. floppy disks, CDs, DVDs, USB drive) shall serve as the primary means of backing up and the restoring files. A copy of the portable media with the saved files shall be placed in each test PC.
- In order to facilitate network based backup and restore, the *C:\project* folder shall be configured to be "shared" on the network with correct domain user group privilege.

3.8 BUYER RESPONSIBILITIES

- Provide engine components/assemblies for mapping.

3.9 RUN OFF

Refer to Section 3 of the Machine and Assembly Run Off Specifications (SP-Q-MARO). Reference paragraphs 4.2.9 and 4.2.10.

The equipment supplier shall provide evidence that any developed software is capable of verifying the acceptability of the intended product. This shall be done prior to the release of production, installation, or servicing. The software will



be rechecked at prescribed intervals. The equipment supplier shall set up the frequency and extent of such checks and maintain a log for evidence.



4.0 APPENDICES

4.1 INDUSTRY STANDARDS

- 4.1.1 IEC-60204-1 Fourth Edition (2002) Safety of Machinery – Electrical equipment of machines, Part 1: General Requirements

4.2 GENERAL MOTORS DOCUMENTS

- 4.2.1 GM Sound Level Specification (GM-1619)
- 4.2.2 Engine Test Approved Components List (CL-M-EngineTestACL)
- 4.2.3 Safety and Ergonomics Specification (SP-S-Safety and Ergonomics)
- 4.2.4 Supplement to IEC-60204-1 (SP-E-60204)
- 4.2.5 GM Laser Alignment Specification No. A1-2004 (GM-1907)
- 4.2.6 GM/Delphi Vibration Standard for Machinery & Equipment (GM-1761)
- 4.2.7 Project Specific Specifications as Outlined in the Bid Package or Project Specific Project Books
- 4.2.8 Assembly System Controls Requirements (SP-E-Assembly Systems Control)
- 4.2.9 Machine and Assembly Run Off Specifications (SP-Q-MARO)
- 4.2.10 Measurement Systems Specification (SP-Q-MSS)
- 4.2.11 Mechanical Specification (SP-M-Mechanical)
- 4.2.12 General Project Specifications (SP-G-General)
- 4.2.13 Training Specification for Manufacturing/Assembly Systems and Equipment (SP-G-Training)
- 4.2.14 Global Manufacturing Drawing Specification Document (SP-G-Drawing)
- 4.2.15 Maintenance of Machinery Specification (SP-G-Maintenance)
- 4.2.16 Roller Conveyor Systems Operational Requirements (SP-M-Roller Conveyor Systems)
- 4.2.17 Hydraulic System Requirements (SP-F-Hydraulic)
- 4.2.18 Lubrication System Requirements (SP-F-Lubrication)
- 4.2.19 Pneumatic System Requirements (SP-F-Pneumatic)
- 4.2.20 Application Note: Engine Cold Test Step Definitions (AN-M-Engine Cold Test Step Definitions)
- 4.2.21 Application Note: Static Spark Plug Test (AN-M-Static Spark Plug Test)

4.3 OIL TEMPERATURE CORRECTION

The oil pressure build up in the engine depends on the viscosity of the oil and therefore on the oil temperature. Measure the oil temperature (t) to allow for a numerical correction back to a nominal temperature (T). A 5th order polynomial is developed through mapping and is used as a factor in the pressure correction. The application shall save the uncorrected values to allow recalculation with a revised correction formula.

For Example:

Equation 5 Oil Pressure as a Function of Oil Temperature

$$p_{corr}(t) = p_{base}(T) - f(t) + p_{meas}$$

Equation 6 Oil Temperature correction function (polynomial form)

$$f(t) = a_0 + a_1 * t + a_2 * t^2 + a_3 * t^3 + a_4 * t^4 + a_5 * t^5$$

Where

t : The measured oil temperature in Celsius

$p_{corr}(t)$: The corrected oil pressure

$p_{base}(T) = f(T)$: The base oil pressure reading at nominal temperature (e.g. $T = 25$ °C)

p_{meas} : The measured oil pressure

$f(t)$: The correction function (in pressure units)

a : The scale factors to establish pressure at nominal temperature (e.g. $t = 25$ °C)

Remarks:

Equation 5 is the base formula. Insert Equation 6 into Equation 5 to perform the compensation.

4.3.1 Temperature correction shall compensate for a temperature range of 10 °C to 60 °C

4.3.2 The coefficients must be double precision and utilize as many decimal positions as possible. Experience shows that at least 10 decimal locations is needed to make the correction accurate.

4.3.3 Temperature Correction Mapping Test Plan

The test supplier shall provide a test plan to enable collection of temperature verses pressure for determination of the coefficients. The base procedure would be to sample temperature and pressure at fixed intervals as the engine is cycled between the high speed oil pressure test RPM and the low speed oil pressure test RPM over the full temperature range. Two curves would be generated, high speed oil pressure verses temperature and low speed oil pressure verses temperature. These curves would then be exported to an ASCII file for determination of the 5th order polynomial coefficients using Microsoft Office Excel (example Figure 24). The low speed curve is different depending on how the oil is heated (i.e. from oil fill or from air temperature or from re-running the engine). Due care should be taken when setting up the coefficients for production use. Averaging coefficients from different runs may help.

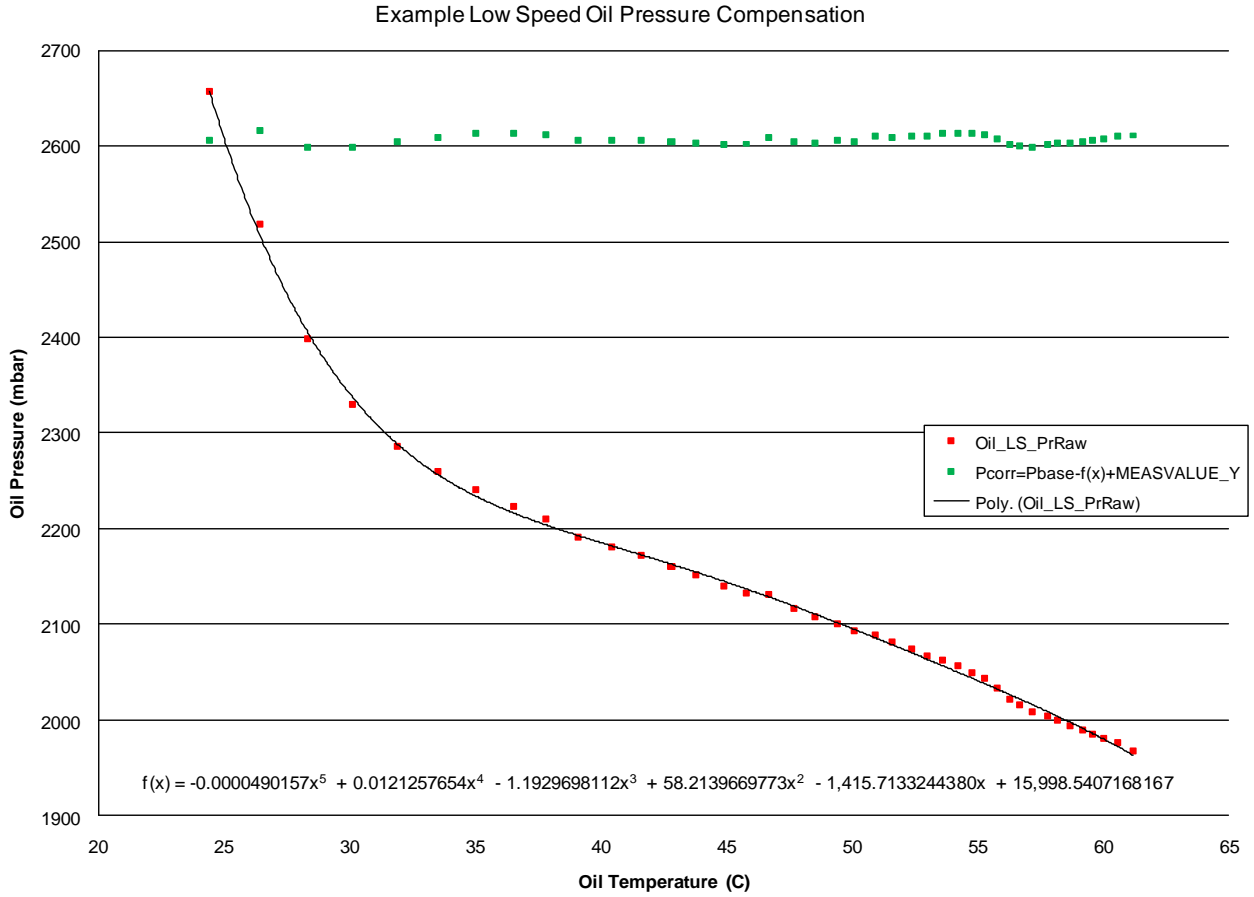

Figure 24: Oil Compensation Curve (Reference Only)

4.4 INTAKE PRESSURE COMPENSATION

It may be necessary to compensate intake pressure for changes in barometric pressure. The same principles discussed in section 4.3 shall be made available for Intake Pressure Compensation

4.5 TORQUE COMPENSATION

It may be necessary to compensate torque for changes in barometric pressure. The same principles discussed in section 4.3 shall be made available for Torque Compensation

INDEX

A

aborts, 26, 42, 48
 acquisition, 12, 16, 29, 30, 33, 35, 36, 37, 38, 47, 59
 Ad Hoc, 52
 adaptations, 21
 adapters, 15
 add a new limit set, 36, 37
 AFM™, 13, 60
 algorithms, 15, 36, 38, 59
 alignment, 18, 20, 21, 58
 Analog, 36
 Analysis, 11, 12, 16, 17, 20, 33, 35, 36, 37, 41, 42, 46, 49, 50, 51, 57
 Approval, 24, 31, 32, 34, 35, 36, 39, 40, 41, 49, 63
 Architecture, 16, 17
 Archive, 46, 48, 59
 Archive Media, 11, 47, 48
 Area under curve, 36
 ASCII, 50, 52, 57, 64
 atmosphere, 23, 24
 Automatic, 11, 15, 20, 21, 37, 38, 42, 43, 44, 47, 49, 53, 54
 Average, 36, 39, 55
 axis, 36, 49, 50, 51, 53, 54, 55

B

backpressure, 24
 backup, 33, 37, 45, 46, 47, 48, 49, 58, 60, 61
 Bad Engine, 50, 57
 BDC, 13, 51
 bell curve, 53
 belt, 28
 bends, 24
 blocked, 59
 board level pre-processing, 33, 36
 Break Away, 40, 41
 Breathing, 15
 Breating, 15

C

cabinet, 33
 Calculate, 35, 52, 56, 57
 Calibration, 12, 21, 23, 24, 29, 30, 36, 37, 38, 39, 45, 57, 58, 59
 cam phaser, 34
 capability, 21, 28, 49, 51, 53, 59
 change log, 37
 channel reading, 38
 Clamp, 12, 18, 19, 20, 42, 43, 58
 Clarification, 60
 Class, 51, 53
 Client, 10, 12, 16, 17, 46, 49
 Clock, 28, 35
 color, 49, 53, 54, 55
 column width, 49, 51, 52

commercially available, 33, 58
 common, 22, 30, 36, 37, 46, 61
 communication, 16, 36, 42
 compare, 22, 23
 compensated, 36
 compensation, 65
 compile, 38
 compliance, 10, 20, 58
 Components, 10, 11, 15, 16, 17, 20, 26, 27, 30, 32, 34, 35, 58, 60, 61, 63
 compression, 23, 33, 35
 conditional statement, 50
 Conductor, 30, 31
 configuration, 17, 23, 24, 50, 53, 54, 55, 57
 conflict, 10
 connections, 20, 26, 31, 33
 construction, 18
 containment, 20, 25
 continuous, 26, 31, 33, 35, 36, 42
 Conveyor, 11, 12, 15, 16, 18, 42, 45, 63
 Conveyor Controller, 11, 16, 42, 45
 copy protection, 35
 costs, 26, 27
 coupling, 15
 Crank, 30, 35, 43, 60
 crank signals, 36
 crosshairs, 50
 current calibration, 38
 custom, 33, 55
 cycle time, 18, 33, 36, 39, 43, 48
 cylinder deactivation, 22, 24, 34, 59

D

Data, 11, 12, 15, 16, 18, 28, 29, 30, 33, 34, 35, 36, 37, 38, 42, 43, 46, 47, 48, 49, 50, 51, 52, 53, 54, 55, 57, 59, 60
 Database, 11, 14, 16, 36, 46, 47, 48, 50, 51, 57, 60
 Date and time, 37, 53
 default, 20, 38, 48, 49, 50, 51, 54, 57
 Defect, 58, 59
 Degrees, 36
 Design, 10, 12, 18, 19, 20, 21, 22, 23, 24, 25, 26, 27, 30, 31, 32, 33, 35, 39, 42, 58
 Detailed Separately, 10, 26, 27, 49, 58
 diagnostic, 11, 12, 18, 33, 45, 46, 49, 59
 dialog boxes, 38, 51
 Diesel, 11, 13, 15, 20, 22, 23, 25, 26, 27, 28, 33, 34, 39, 41, 42, 60
 digital, 11, 36, 59, 60
 disable, 42, 43, 44, 50
 discrepancy, 48
 displayed, 36, 37, 38, 45, 46, 48, 51, 52, 53, 54, 55, 57
 Documentation, 20, 33, 37, 58, 59, 60
 DOHC, 13, 39
 down, 15, 23, 28, 33, 38, 50, 51, 57
 drawings, 30, 31, 58
 drip pan, 20, 25



Drive, 18, 19, 20, 24, 28, 29, 33, 35

E

ECM, 13, 16
ECU, 13
edit parameters, 50
EGR, 13, 22
emergency stop, 20, 48
encoder, 28, 35
Encoder, 28, 35
Engine, 11, 12, 13, 15, 16, 28, 30, 31, 34, 35, 36, 37, 41, 48, 50, 51
engineering units, 37
equipment, 2, 10, 17, 18, 20, 21, 25, 26, 27, 28, 30, 31, 32, 33,
42, 45, 49, 58, 59, 60, 61, 63
Ergonomics, 63
Error messages, 48
evacuated, 15
evacuation, 20, 25, 26, 27, 41
evaluation case, 44
EVC, 11, 13
event driven, 28
EVO, 11, 13
Excel, 50, 55, 64
exclude tests, 57
exemption, 10
exhaust, 11, 12, 18, 19, 20, 23, 24, 25, 29, 30, 32, 35, 36, 39, 43,
51
Export, 48, 50, 52, 55, 57

F

false rejects, 56
fan noise, 20
fetch, 46
Filters, 11, 23, 25, 26, 33, 34, 36, 50, 59
firmware, 33
Fixture, 12, 18, 20, 30, 58
flag, 48
flexible, 24, 27, 37, 44, 47, 51
Flywheel, 15, 20, 33
format, 37, 49, 52, 53, 55, 58, 59, 61
formulas, 52, 57
FPGA, 13, 35
free-floating, 20
FTP, 56
FTQ, 56
Fuel Return, 11
Fuel Supply, 11, 20
full report, 51
full scale range, 31

G

gain, 36, 38
Gain, 38
gasoline, 39, 40
Glow Plug, 13

Glow Plug Control Module, 13
GPCM, 13
graph, 38, 49, 50, 51, 53, 54, 55, 56
Ground, 30, 31

H

Hard Drive, 11, 16, 35, 36, 45, 46, 48, 49, 58, 60, 61
head, 24, 30, 32, 59
header, 48, 49, 51, 55
help, 10, 11, 22, 23, 36, 38, 39, 56, 64
high, 12, 15, 16, 18, 20, 24, 25, 32, 33, 36, 37, 52, 53, 54, 55, 56,
64
histogram, 36, 51, 53, 55, 56
HMI, 11, 13, 16, 35, 36, 37, 42, 43, 45
Host, 10, 11, 16, 17, 33, 36, 37, 42, 46, 48
HPLT, 13, 26
Hydraulic, 20

I

Ignition, 12, 18, 21, 30, 32, 33, 34, 36, 39, 42, 43, 60
Import, 50, 57
installation, 20, 30, 58, 60, 61
intake, 11, 12, 18, 19, 20, 22, 23, 24, 25, 29, 30, 32, 35, 36, 39, 42,
43, 51, 60, 65
integrated, 18, 23, 24, 25, 26, 35
Interactive, 50
interface, 25, 34
interfere, 48
intervention, 33, 35, 36, 42, 46, 47
Isolate, 11, 18, 20, 30, 31, 34, 35, 36
IVC, 11, 13
IVO, 11, 13

K

keyboard, 12, 38, 51

L

Landscape, 49
language, 37
laser, 20
least-squares-fit, 54
licensing, 33
Limit, 15, 35, 36, 37, 41, 42, 47, 48, 49, 50, 51, 52, 53, 56, 57, 59
lists, 49, 50, 51, 55
local, 11, 47, 48, 51
Locate, 12, 16, 18, 19, 20, 24, 25, 33
Log, 37, 42, 51
LOMA, 13, 21, 60
low, 11, 13, 15, 24, 31, 32, 33, 36, 48, 52, 53, 54, 55, 56, 64
low point, 24
LPLT, 13, 26



M

machining locating holes, 18, 19
main screen, 37, 46, 52
Maintenance, 20, 25, 26, 49, 58, 60, 63
manual, 23, 24, 29, 33, 38, 51, 60
Mapping, 58, 59, 64
MARO, 60, 61, 63
Master, 11
Maximum, 28, 29, 36, 39
mean, 10, 52, 53, 56
menu driven, 39, 51
meter, 30
Metering valve, 22, 60
Minimum, 36, 39
model, 24, 35, 36, 55
Module, 13, 16, 30, 33
motor, 12, 15, 20, 29, 42
mouse, 12, 37, 38, 39, 49, 50, 51, 53, 57
MU, 13
multitask, 37

N

Navigation, 37, 39
Network, 16, 17, 33, 36, 46, 48, 49, 61
new tests, 38, 49
NIST, 13, 36, 58
noise, 20, 23, 24, 31, 38
NVH, 13, 18, 20, 21, 33, 34, 36, 40, 41, 42

O

OCV, 13, 21, 59, 60
ODBC, 13, 16, 46
offset, 36, 38, 54
Offset, 38
Oil, 13, 14, 15, 20, 21, 25, 30, 31, 32, 33, 35, 36, 38, 40, 41, 42,
43, 48, 54, 59, 60, 64, 65
operating system, 35, 46, 61
operators, 25, 50, 51
Oscilloscope, 30, 36
outlier, 51, 56
overlay, 32, 38

P

P/S, 13
Pallet, 11, 12, 15, 18, 19, 20, 42, 48, 50, 55
parallel, 35, 37
Parameter, 34, 36, 39, 43, 44, 46, 47, 48, 49, 50, 51, 52, 53, 54, 55,
56, 57, 58, 59
partition, 45, 46, 49, 58
password, 37, 49
patent, 33
PB, 13, 38, 46, 51
PC, 11, 12, 16, 31, 35, 36, 37, 43, 45, 46, 47, 48, 49, 60, 61
PCL, 11, 13

PCM, 13, 16
PCV, 13, 22
per cylinder, 23, 24, 32, 36
phaser position, 35
POL, 11, 13
Power, 12, 30, 33, 46
pressure, 11, 12, 20, 22, 23, 24, 25, 26, 30, 32, 33, 34, 42, 43, 44,
48, 54, 60, 64, 65
prime, 20, 26, 41
Print, 49
probe, 18, 19, 20, 21, 24, 26, 30, 32, 43
procedure, 20, 36, 37, 60, 61, 64
processing, 16, 33, 36, 38, 51
Proposal, 15, 21, 27, 60
protection, 20, 30, 35, 37, 47
PRV, 13
pull down menus, 38
pump, 20, 22, 25, 26, 32, 39
purging, 25, 27
push or pull, 46

Q

QD, 13, 25
qs-STAT, 60
qualified, 37
quick disconnect, 25, 30
quotation, 18, 33, 59
quote, 26, 27, 49, 58, 59

R

range, 28, 31, 32, 33, 39, 50, 52, 53, 56, 57, 64
reboot, 36, 37, 38, 42, 46
receive, 26, 46
Recycle, 43, 44, 55
referenced to, 35
regulating valve, 22, 26, 33, 60
rejected, 12, 18, 36, 43, 55
Reluctor Test, 40, 41
Remote system support, 49
Repair, 10, 11, 12, 16, 30, 36, 37, 45, 46, 48, 51, 56, 61
Report, 10, 12, 16, 17, 36, 37, 46, 48, 49, 50, 51, 52, 53, 56, 59, 60,
61
Report/Client, 12
requirements, 10, 12, 18, 19, 20, 29, 30, 32, 33, 37, 39, 40, 41, 42,
45, 47, 49, 58, 60
Rerun, 33, 36, 42, 43, 51, 57, 64
resistance, 29, 34
restore the server, 60
Retest, 35, 41, 43, 44, 55
RF Tag, 13
right angle, 24
rigid, 24
RPM, 20, 24, 26, 28, 29, 31, 32, 33, 35, 40, 41, 44, 64
RPS, 13
RTSI, 13
Runoff, 60, 61, 63



S

Safety, 30, 41, 42, 63
SAI, 14, 22, 23, 24
Sample, 28, 29, 37, 38
sample size, 53
scalable, 38
scatter, 51, 54
Screen, 37, 38
Seal, 20, 24, 25, 30
Secondary Air Injection, 14, 22
Security, 37, 46
self-locating, 20
sensors, 12, 15, 31, 32, 34
serial number, 38
Server, 36, 46, 48, 60, 61
Set Point, 15, 38
Shall, 2, 10, 12, 15, 17, 18, 20, 21, 22, 23, 24, 25, 26, 27, 28, 29,
30, 31, 32, 33, 34, 35, 36, 37, 38, 39, 41, 42, 43, 44, 45, 46, 47,
48, 49, 50, 51, 52, 54, 56, 57, 58, 59, 60, 61, 64, 65
Shield, 30, 31
shift, 12, 47, 50, 53, 55
Should, 2, 10, 20, 26, 36, 37, 39, 41, 43, 45, 46, 47, 48, 49, 50,
51, 52, 53, 54, 55, 56, 57, 58, 64
Shunt, 32, 36
shuttle, 12, 18
SIDI, 14
signal, 12, 21, 24, 30, 31, 32, 33, 34, 35, 36, 42
signal-conditioning, 30
slide, 18, 23, 24
Slope, 36, 50, 54
Software, 12, 16, 26, 28, 33, 34, 35, 36, 37, 38, 39, 42, 43, 44, 46,
47, 49, 52, 57, 59, 60, 61
SOR, 14, 26, 39, 42, 58, 60
sort, 49, 55
Sound, 24, 63
spare, 33, 46, 60
SPC, 49, 50, 51
specification, 2, 11, 13, 15, 20, 39, 47, 53, 60
speed, 12, 15, 16, 18, 26, 28, 29, 32, 33, 35, 36, 38, 39, 42, 64
spreadsheet, 10, 26, 27, 49, 52, 55, 58
stabilization delay, 35
stabilizer, 19
standard, 25, 29, 38, 46, 51, 52, 53, 57
Standard Deviation, 36, 54, 56, 57
statistical analysis, 16
statistical tools, 12, 35, 36, 41, 43, 52
status, 16, 36, 48, 51, 57
studies, 60
supercharging, 23
Supercharging, 22, 23, 29
supplier, 10, 15, 17, 20, 21, 22, 23, 25, 26, 27, 28, 30, 31, 32,
33, 34, 37, 39, 42, 49, 52, 58, 59, 60, 61, 64
synchronized, 28, 36
system, 10, 11, 12, 15, 16, 17, 18, 20, 21, 22, 23, 24, 25, 26, 27,
28, 31, 33, 34, 35, 36, 37, 41, 42, 45, 46, 47, 48, 49, 51, 58, 59,
60, 61, 63

T

tables, 46, 49, 50, 51
tag, 15, 42
TDC, 14, 28, 35, 51
Temperature, 11, 21, 25, 26, 33, 35, 36, 64
Terminate, 30, 31
Test, 15, 16, 22, 23, 24, 28, 29, 30, 31, 32, 33, 35, 36, 37, 38, 39,
40, 41, 42, 43, 44, 46, 47, 48, 49, 51, 54, 55, 58, 59, 60, 65
threshold, 36
throttle body, 30
Time, 13, 29, 37, 38, 50, 52, 56
timestamp, 48
Timing, 12, 13, 14, 23, 24, 35, 59, 60
tolerance, 53, 60
top dead center, 28, 35
torque arm, 29
Training, 39, 58
Transducer, 11, 12, 16, 20, 22, 23, 24, 25, 29, 30, 31, 32, 33, 38,
39, 57, 58, 59, 60
Transfer Unit, 12, 18
Transforms, 36
transmission flange, 18, 19
trends, 49, 53
trigger, 35, 36, 43, 46, 48
tubing, 20, 24, 31
Type 1, 60
Type 1A, 60
Type 2, 60

U

units, 12, 20, 32, 37, 51, 52, 64
UPS, 12, 33, 46
User, 37, 46, 51

V

values, 36, 38, 47, 50, 51, 52, 53, 54, 56, 57, 59, 64
valves, 23, 24, 26, 30, 32, 33
VDO, 14
verification, 12, 37, 38, 39, 45
version, 2, 38, 47, 48
version changes, 38
volume, 22, 23, 24, 26, 27, 30
VSI, 14
VVT, 14

W

Waveform colors, 37
Weather, 33, 35, 45
well-documented, 61
Windows, 39, 46, 48, 51, 57
work parameters, 47
wraparound, 36



X

X bar and Moving Range, 54, 56, 57
X bar and R, 54, 56, 57
XDCR, 14

Z

zero crossing, 36
zoom, 37, 49