



---

*GM Powertrain*

**Global Machinery and Equipment  
Request for Quotation  
Statement of Requirements (SOR)**

**Global FWD 6 Speed Transmission**

**Project Number: F269**

**RFQ Number: 2400655605**

**Document:**

**Version: G1.0**

Published Date: 12-Nov-2008

Revised Date: 03-Dec-2009

Revised Date: 15-Mar-10

Release Date: 05 April 2010

SOR created and approved by: GF6 Leads

Global Manufacturing Engineering Organizations of GM Powertrain  
Approval signatures on file at GMPT Global Headquarters Pontiac, MI.

**Document Management Information**

This SOR shall take effect as of the Published Date of the document.

The controlled version of this document is maintained by the responsible GMPT Manufacturing Engineering Department. Any printed copy is an uncontrolled copy.

Any questions or comments with respect to this specification should be directed to the GMPT Manufacturing Engineer responsible for the project.

**Revision History**

Published	Version	Section Number	Change Description & Impact
19-SEP-2008	G1.0	ALL	APPROVED GLOBAL RELEASE.
12-NOV-2008	G1.1	3.3	REVISED WARRANTY PERIOD TO DURATION OF ONE YEAR.
02-OCT-2009	G1.2	2.6, 2.8, 5.1, 5.3, 6.0-11.0	GF6 TEMPLATE SOR FOR REVIEW – FUTURE SPECIFICATIONS & COMPONENTS UPDATES
15-OCT-2009	G1.2	7.6, 7.10	GMW16037 TEST METHOD TO QUANTIFY CLEANLINESS ADDED, DPM PART MARKINGS UPDATED TO NEW EUN/PUN.
29-OCT-2009	G1.2	7.14.1 (7.15)	QUALITY ANDON SPEC UPDATE FOR CMM STACKPOLE LIGHT CLARIFICATION
02-NOV-2009	G1.2	2.6, 2.8, 7.10, 8.2, 9.0	USA PLANT POWER INFORMATION UPDATED. DUAL LANGUAGE REQUIREMENT TO INCLUDE TEST PC'S, SP-E-POWERTRAIN MEMORY MAP SPECIFICATION DATE CHANGED. MEMORY MAP APPLICATION NOTES DELETED. UPDATE PILZ PROJECT BOOK DATE/VERSION.
05-NOV-2009	G1.2	2.7, 3.4, 4.1, 5.3, 9.0, 10.0	DRAWINGS, BOM AND SPARE PARTS CLARIFICATIONS
09-NOV-2009	G1.2	2.6	BAY CITY NO CHILLED WATER AVAILABLE.
12-NOV-2009	G1.2	5.3	PLANT ENGINEERING REBUILD AND REHABILITATION REQUIREMENTS
17-NOV-2009	G1.2	7.10 7.12 8.2.1	CELL CONTROLLER FUNCTIONAL REQUIREMENTS ADDED AS ADDENDUM TO SP-E-MACHINING-SYSTEM SPECIFICATION. SLASH-RATED COMPONENTS NOT ALLOWED. UPDATED FASTENING SPEC INCLUDED.
18-NOV-2009	G1.2	2.7, 2.7.1 2.8	DUAL LANGUAGE PRICING REQUIREMENTS. CANADA TSSA, ESA AND PSR REQUIREMENTS.
18-NOV-2009	G1.2	7.10	CNC PART PROGRAMMING REQUIREMENTS ADDED (PCOS, COMP, ETC.)
19-NOV-2009	G1.2	4.5	EXPORT COMPLIANCE CLARIFICATION
03-DEC-2009	G1.2	9.0	PLANT FLOOR CONTROLS SYSTEM REQUIREMENTS, MINIMUM PC REQUIREMENTS



**Table of Contents**

**1.0 INTRODUCTION ..... 6**

1.1 CONTRACTUAL INTENT ..... 6

1.2 ACCESS TO GMPT SPECIFICATIONS ..... 6

1.3 DEVIATIONS TO GM/GMPT STANDARDS, SPECIFICATIONS, AND COMPONENTS ..... 6

1.4 SUPPLIER COMPLIANCE CERTIFICATION ..... 7

1.5 PRIMARY POINT OF CONTACT - GMPT MANUFACTURING ENGINEER ..... 7

    1.5.1 GMPT DESIGNATED SECONDARY POINT(S) OF CONTACT ..... 7

**2.0 PROJECT OVERVIEW ..... 8**

2.1 PROJECT SUMMARY ..... 8

2.2 PROJECT TIMING DATES ..... 8

2.3 DESTINATION SITE LOCATION ..... 9

2.4 SHIPPING ..... 10

2.5 SELLER INSTALLATION AND COMMISSIONING SUPPORT ..... 11

    2.5.1 DESTINATION SITE LANGUAGE REQUIREMENTS ..... 11

**3.0 QUOTATION ..... 11**

3.1 “NO QUOTE” AND RETURN OF GMPT DOCUMENTATION ..... 11

3.2 QUOTATION TIMING AND DELIVERY ..... 12

    3.2.1 QUOTATION CLARIFICATION MEETING(S) ..... 12

3.3 REQUIRED WARRANTY ..... 12

3.4 SPARE PARTS ..... 12

3.5 PERISHABLE ITEMS ..... 12

**4.0 GMPT BASELINE REQUIREMENTS ..... 13**

4.1 PRODUCT INFORMATION ..... 13

4.2 MANUFACTURING SYSTEM REQUIREMENTS ..... 14

4.3 BASELINE PROPOSAL REQUIREMENTS ..... 14

    4.3.1 Feature Charts ..... 14

    4.3.2 Manufacturing Process ..... 14

    4.3.3 Part Traceability / Identification ..... 14

    4.3.4 Locating and Clamping ..... 17

    4.3.5 Manufacturing Capability Requirements ..... 17

    4.3.6 Manufacturing System Architecture ..... 17

    4.3.7 Special Machine (Bushing Press) ..... 17

    4.3.8 Machine Requirements ..... 18

    4.3.9 Tool Path Part Programming Requirements ..... 18

    4.3.10 Part Fixturing Concepts and Requirements ..... 18

    4.3.11 Tooling Concept and Requirements ..... 20

    4.3.12 Error Proofing Features ..... 20

    4.3.13 GMPT REQUESTED OPTIONS TO BASELINE PROPOSAL ..... 20

    4.3.14 SUPPLIER REQUESTED OPTIONS OR ALTERNATES ..... 20

4.4 QUOTATION DELIVERABLES ..... 20

4.5 TECHNICAL DATA TO SUPPORT EXPORT CLASSIFICATION OF MACHINERY AND EQUIPMENT ..... 21

4.6 SUPPLIER PROJECT PLAN ..... 21

4.7 SUPPLIER INITIAL PRICING SPREADSHEET ..... 21

4.8 PROJECT QUALITY REQUIREMENTS ..... 21

4.9 ENVIRONMENTAL REQUIREMENTS ..... 22

**5.0 PROJECT ENGINEERING AND IMPLEMENTATION ..... 22**

5.1 CONCEPT DESIGN CONFIRMATION (SE PHASE) ..... 22

5.2 “IN-PROCESS” REQUIREMENTS AND DOCUMENTATION ..... 23



**Table of Contents**

5.3 REBUILD AND REHABILITATION REQUIREMENTS ..... 24

5.4 INTERFACING TO AUTOMATION, EQUIPMENT, OR SYSTEMS PROVIDED BY OTHERS..... 25

**6.0 GMPT PROVIDED ATTACHMENTS ..... 26**

**7.0 GMPT PROJECT SPECIFICATIONS ..... 26**

7.1 GENERAL PROJECT SPECIFICATION ..... 26

7.2 SAFETY & ERGONOMICS SPECIFICATION ..... 27

    7.2.1 ASSEMBLY SYSTEM ERGONOMIC LINE HEIGHT ..... 27

7.3 MAINTENANCE SPECIFICATION ..... 27

    7.3.1 PREDICTIVE MAINTENANCE TECHNOLOGIES ..... 27

7.4 DRAWING SPECIFICATION ..... 28

7.5 TRAINING SPECIFICATION ..... 29

7.6 LAYOUT SPECIFICATION ..... 29

7.7 QUALITY PRE-ACCEPTANCE AND FINAL ACCEPTANCE RUNOFF SPECIFICATION ..... 29

    7.7.1 QUALITY PRE-ACCEPTANCE AND FINAL ACCEPTANCE RUNOFF PLAN..... 29

7.8 MEASUREMENT SYSTEMS APPLICATION SPECIFICATION ..... 29

7.9 GAGE AND COORDINATE MEASURING MACHINE (CMM) SPECIFICATION..... 30

7.10 ELECTRICAL CONTROL SPECIFICATION ..... 30

    7.10.1 Transmission Line and Sub-Assemblies ..... 33

    7.10.2 Forecasting of Primary Controls Supplier Long Lead Components ..... 34

    7.10.3 Sub Contracted Hardware and Software Controls Design ..... 34

    7.10.4 Robot Simulation ..... 34

    7.10.5 Retool of Equipment ..... 34

    7.10.6 Training & Support..... 34

    7.10.7 FACS & NMS..... 34

    7.10.8 Pneumatic..... 35

    7.10.9 Electrical ..... 35

    7.10.10 Safety ..... 36

    7.10.11 Error Proofing Vision Systems ..... 38

    7.10.12 IT Systems ..... 39

    7.10.13 Fastening Network ..... 40

    7.10.14 HMI..... 40

    7.10.15 MWS and Conveyor Controller Node Plate Requirements..... 40

    7.10.16 Flash Drive PC..... 40

7.11 FLUID POWER CONTROL SPECIFICATION ..... 40

7.12 PROCESS MECHANICAL EQUIPMENT SPECIFICATION ..... 41

7.13 TOOLING SPECIFICATION..... 42

7.14 PLANT ENGINEERING PROCESS SUPPORT EQUIPMENT SPECIFICATION..... 42

7.15 GLOBAL MANUFACTURING SYSTEM AND QUALITY ANDON REQUIREMENTS ..... 42

    7.15.1 Andon: ..... 42

    7.15.2 Material low/high:..... 43

    7.15.3 Assembly: ..... 43

    7.15.4 Gage spurs and reject spurs: ..... 44

    7.15.5 Controls: ..... 44

    7.15.6 Line of Sight:..... 44

    7.15.7 Gage Tables and visual inspection areas: ..... 44

    7.15.8 ATT (Actual Takt Time): ..... 44

    7.15.9 Independent Repair & Confirmation: ..... 45

    7.15.10 Built in Quality: ..... 45

    7.15.11 Maintenance: ..... 45

    7.15.12 Coordinate Measurement Machine (CMM) Andon & Stackpole Light Functionality Clarifications ..... 45

7.16 FIRE PROTECTION REQUIREMENTS..... 48

7.17 LASER REQUIREMENTS..... 48

**8.0 EQUIPMENT COMPONENTS AND SUBSYSTEMS..... 49**



**Table of Contents**

8.1 SUPPLIER PREFERRED COMPONENTS AND SUB-SYSTEMS ..... 49

8.2 GMPT APPROVED COMPONENTS AND SUB-SYSTEMS..... 50

    8.2.1 ELECTRICAL COMPONENT LISTS AND PROJECT BOOKS ..... 50

    8.2.2 FLUID POWER COMPONENT LISTS AND PROJECT BOOKS..... 51

    8.2.3 MECHANICAL AND PROCESS EQUIPMENT COMPONENT LISTS AND PROJECT BOOKS ..... 51

9.0 GMPT PROJECT APPLICATION NOTES ..... 52

10.0 GMPT PROJECT FORMS..... 52

11.0 SUPPLIER COMPLIANCE CERTIFICATION STATEMENT ..... 55



GMPT Document

GF6 F269 Transmission Case  
Machining**Supplier Compliance  
Confirmation**  
(YES – Comply)  
(NO - Deviation Request Required)

## 1.0 INTRODUCTION

GMPT Specification **SP-G-General (General Project Specifications)** provides the Supplier guidance in completing the SOR in accordance with GMPT's common general requirements for quotation and Supplier project management requirements for all machinery and equipment purchases. The Supplier shall prepare their quotation in compliance with the requirements of this **SOR, SP-G-General (General Project Specifications)**, and applicable requirements found in GM/GMPT Standards and Specifications.

All information provided by GMPT either verbal, part print, process details, or otherwise written, is to be considered CONFIDENTIAL and shall not be released to competitors of General Motors without the explicit written consent of General Motors. GMPT information is being provided to assist in your quotation preparation and shall not be divulged to other third parties except as necessary to complete this quotation and held in strict confidentiality.

### 1.1 CONTRACTUAL INTENT

This Statement of Requirements (SOR), and associated GM/GMPT Standards, Specifications, data, and information issued in support of this project, are issued by General Motors Powertrain (GMPT) as a part of the formal GM/GMPT Request for Quote (RFQ) package and shall not initially be considered to be a contract of any sort.

This SOR may be amended and revised during the quotation, discovery, and evaluation process. All amendments to this SOR shall be agreed to by both GMPT and the selected Supplier and documented in writing by GMPT.

Upon award of a Purchase Order the following become part of the binding contract agreement:

- This SOR, including attachments, documented amendments, and referenced GMPT data and information.
- GM/GMPT Specifications, Standards, and Component Lists. Including any exceptions granted to the Supplier in accordance with the GMPT Supplier Deviation Request process (Refer to **FM-G-Deviation Request**).
- Changes and alterations to the contract as approved by GMPT through GMPT **Manufacturing Engineering Change Request (MECR)** change management procedures.
- Supplier quotation and project information submitted to GMPT.

The revision level of all documents and information referenced herein will be fixed at issue of the Purchase Order (PO), unless otherwise agreed upon by both Supplier and the responsible GMPT Manufacturing Engineer (ME) in writing and in accordance with GMPT change management procedures.

### 1.2 ACCESS TO GMPT SPECIFICATIONS

The Supplier shall access the authorized versions of applicable GM Standards, GMPT Specifications (SP-x-yyyy), Component Lists (CL-x-yyyy), and standard GMPT forms (FM-x-yyyy) and additional documentation such as Application Notes (AN-x-yyyy) for this project via the internet at <http://www.gmsupplypower.com/>.

The Supplier must work with their GPSC Buyer to have their company information entered into the GPSC CSIDS database then follow registration instructions posted on the <http://www.gmsupplypower.com/> internet website. The Supplier must be registered with Dun & Bradstreet (<http://www.dnb.com/us/>) and have an appropriate DUNS number before GPSC can enter the Supplier information into the CSIDS database.

**If the Supplier is not currently registered as a user in GM SupplyPower early enrollment is strongly recommended to avoid excessive delays in obtaining GMPT information required for this project.** (Refer to application note **AN-G-GM SupplyPower Access**)

### 1.3 DEVIATIONS TO GM/GMPT STANDARDS, SPECIFICATIONS, AND COMPONENTS

The Supplier may submit requests for deviation, or exception, to GM/GMPT standards prior to quotation submittal, or as part of their quotation response.



GMPT Document

GF6 F269 Transmission Case  
MachiningSupplier Compliance  
Confirmation  
(YES – Comply)  
(NO - Deviation Request Required)

Deviation Requests shall not be in effect and cost impact shall not be included in the Supplier's quoted pricing, until GMPT provides written approval to the Supplier in accordance with GMPT change management procedures (Refer to **SP-G-General** and **FM-G-Deviations Request**).

#### 1.4 SUPPLIER COMPLIANCE CERTIFICATION

The authorized Supplier agent shall certify compliance of all deliverables with the requirements of GM/GMPT Standards and Specifications, the SOR, and resulting contract agreements with GMPT by completing and signing the SOR Supplier Compliance Certification Statement at the end of the SOR and submitting it to GMPT with their quotation.

#### 1.5 PRIMARY POINT OF CONTACT - GMPT MANUFACTURING ENGINEER

The GMPT Manufacturing Engineer listed below is the primary point of contact responsible to communicate project technical requirements to Suppliers. The GMPT Manufacturing Engineer may authorize additional designated GMPT Manufacturing Engineers to communicate project technical requirements to the Supplier. **The GMPT Manufacturing Engineer – Primary Point of Contact must be copied on all communications transmitted between the Supplier and designated GMPT Secondary Points of Contact.**

<b>GMPT Manufacturing Engineer:</b>	Daniel Gullede
<b>Street Address:</b>	777 Joslyn Ave
<b>City, State, ZIP Code:</b>	Pontiac, MI 48340
<b>Mail Code:</b>	483-720-450
<b>Phone / Fax:</b>	248.343.7397
<b>E-mail address:</b>	daniel.gullede@gm.com

#### 1.5.1 GMPT DESIGNATED SECONDARY POINT(S) OF CONTACT

<b>GMPT Controls Engineer:</b>	Kim Fuller	<b>GMPT Plant Engineer:</b>	Omar Monge
<b>Street Address:</b>	823 Joslyn Ave	<b>Street Address:</b>	823 Joslyn Ave
<b>City, State, ZIP Code:</b>	Pontiac, MI 48340	<b>City, State, ZIP Code:</b>	Pontiac, MI 48340
<b>Mail Code:</b>	483-730-362	<b>Mail Code:</b>	483-730-107
<b>Phone / Fax:</b>	248-830-8772	<b>Phone / Fax:</b>	248 632 3134
<b>E-mail address:</b>	kimberly.fuller@gm.com	<b>E-mail address:</b>	luis.monge@gm.com
<b>GMPT Industrial Engineer:</b>	Deanna Hawker	<b>GMPT Central Layout Engineer:</b>	Michael Schmitz
<b>Street Address:</b>	777 Joslyn Ave	<b>Street Address:</b>	823 Joslyn Ave
<b>City, State, ZIP Code:</b>	Pontiac, MI 48340	<b>City, State, ZIP Code:</b>	Pontiac, MI 48340
<b>Mail Code:</b>	483-720-450	<b>Mail Code:</b>	483-730-107
<b>Phone / Fax:</b>	248-977-9284	<b>Phone / Fax:</b>	248-804-6761
<b>E-mail address:</b>	deanna.hawker@gm.com	<b>E-mail address:</b>	michael.schmitz@gm.com
<b>GMPT Tool Engineer:</b>	Gabriel Gonzalez		
<b>Street Address:</b>	777 Joslyn Ave		
<b>City, State, ZIP Code:</b>	Pontiac, MI 48340		
<b>Mail Code:</b>	483-720-450		
<b>Phone / Fax:</b>	248-978-8869		
<b>E-mail address:</b>	gabriel.gonzalez@gm.com		



GMPT Document

GF6 F269 Transmission Case  
MachiningSupplier Compliance  
Confirmation  
(YES – Comply)  
(NO - Deviation Request Required)

## 2.0 PROJECT OVERVIEW

### 2.1 PROJECT SUMMARY

The project will deliver a manufacturing metal-cutting system to produce the 6T40 and 6T45 Transmission Cases and flexibility to accommodate the 6T30 and BAS+ Transmission Cases within the GF6 Family. The system will produce these components safely, at high quality, at the desired production rate, on schedule, and with design consideration for a high level of flexibility.

To achieve the goals, the project will use existing Metal Cutting Machines and Ancillaries/Material Handling, new Automation and Material Handling, new Fixtures, new Tools, and any other required new ancillary equipment.

In general, the scope of supply is to:

- Receive and Install General Motors Equipment on the Suppliers Floor
- Complete a full evaluation of the equipment
- Remove any existing fixtures, tooling, and machine sub-system not required for the project for disposition by General Motors.
- Design and Build necessary updates to the machines (to achieve project goals and SOR requirements)
- Design and Build new Fixtures and Tooling
- Design and Build new Automation, Material Handling, and Ancillary Equipment as needed for the system
- Setup and Debug manufacturing system per runoff requirements
- Prepare Equipment for shipment to the General Motors facility
- Provide on-site installation and qualification support personnel at the General Motors facility

### 2.2 PROJECT TIMING DATES

Project dates given in this SOR are subject to change based on the future GMPT development of the project. The following are forecasted key dates provided by GMPT as a basis for the Supplier to forecast their milestone dates for the project.

KEY PROJECT DATES	FORECAST DATE (YYYY-MM-DD)
Quotation Due Date	2010-05-15
Anticipated Contract Award Date	2010-06-30
1 <sup>st</sup> Equipment Delivery at GMPT Facility	2011-04-15
Last Equipment Delivery at GMPT Facility	2011-08-15
1 <sup>st</sup> Equipment Ready for Final Acceptance at GMPT Facility	2011-06-15
Last Equipment Ready for Final Acceptance at GMPT Facility	2011-10-15
GMPT Facility Start of Production (SOP) Date	2012-01-02



GMPT Document

GF6 F269 Transmission Case  
MachiningSupplier Compliance  
Confirmation  
(YES – Comply)  
(NO - Deviation Request Required)**2.3 DESTINATION SITE LOCATION**

GM will be responsible for all civil engineering functions to prepare the site for the machinery and equipment installation. The Supplier shall include in their quotation response package notification to GMPT of any machinery and equipment having installation and operational requirements exceeding the site specific parameters listed below.

The Supplier may request access to the project site, but will not be compensated to do so.

The following site specific parameters shall be used in quoting and design considerations:

Glendale Avenue Plant, 570 Glendale Avenue, St. Catharines, Ontario, Canada	
Plant Ambient Temperatures Range:	
Minimum Temperature	50°F (when production is not running)
Maximum Temperature	100°F (when production is not running)
Steady State Temperature:	78°F (when production is running, steam is turn on when plant temperature drops below 65°F)
Humidity	Fluctuate Accordingly (none condensing)
Plant Air Conditioning / Tempering:	Tempering
Plant Altitude:	426 feet above sea level
Plant Main Air Pressure:	85 psig, (Header Pressure: 75 psi), 34°F Dewpoint at the PH
Equipment Design Air Pressure:	60 psig
Raw Water Pressure:	
Operating Pressure	50 psig
Maximum Pressure	75 psig
Winter Temperature	40°F
Summer Temperature	75°F
City Water:	
Operating Pressure	60 psig
Maximum Pressure	90 psig
Process Chilled Water:	
Normal Pressure Across Any Heat Exchanger	? 7 psig
Maximum Pressure Across Any Heat Exchanger	10 psig
Minimum Temperature Supply	55°F
Maximum Temperature Supply	60°F
Power Distribution System:	13.8 KV / 480 V ± 10%, 3 Phase, 3 Wire, 60 Hz
West Plant Transformer Windings	Δ / Y High Resistance Grounded (Ungrounded System)
East Plant Transformer Windings	Δ / Δ (Ungrounded System)
Maximum Floor Space Available:	N/A
Plant Truss Height:	Varies (16' to 52' from the floor to the underside of the roof truss)
Floor Construction:	8"-15" Thick Concrete Slab, Steel Fibre Reinforced Concrete or Re-bar Reinforced Concrete
Floor Trenches, Channels, and Pits:	Yes



<b>GMPT Document</b>	<b>GF6 F269 Transmission Case Machining</b>	<b>Supplier Compliance Confirmation</b> (YES – Comply) (NO - Deviation Request Required)
----------------------	---	--

### 2.4 RE-DEPLOY EQUIPMENT DOCUMENTATION

Documentation (drawings, schematics, etc) for the equipment that is planned to be reused (existing General Motors assets) can be found in Appendix Z. A preliminary list of asset assignments is included in the table below:

Transmission Case			Torque Converter Housing			Valve Body		
OP	Model	Asset Tag	OP	Model	Asset Tag	OP	Model	Asset Tag
10	N4Q	100005463	10	N4Q	100005470	10	N4V	100005449
		C00362			C00369			100005450
		100037257			100037269	100037727		
		C00377			C00384	100005455		
20	N5H	100005464	20	N4Q	100005471	20	N4V	100005456
		C00363			C00370			100005457
		100037259			100037271	100037728		
		C00378			C00385	100037731		
30	N4Q	100005465	25	Press	100037842	30	N4Q	100037734
		C000364			100037843			100005453
		100037261	100005467	100037737				
		C00379	C00366	10003778				
40	N4Q	100005466	30	N5H	100037265	HP Coolant Unit	HP Coolant	100005461
		C00365			C00381			100005462
		100037263			100005472	100064233		
		C00380			C00371	C01123		
50	N5H	100005468	40	N4Q	100037273	Pumpback System	Pumpback w/platform	100064235
		C00367			C00386			C01125
		100041705			100006582	100037739		
		C00382			C00779			
60	N5H	100005469	Automation	Overhead Robot System	C00780			
		C00368			C00776			
		100037267			100005478			
		C00383			100005479			
Case Automation	Overhead Robot System	100006579	HP Coolant Unit	HP Coolant	C01036			
		100006580			C01037			
		C00778						
		C00777						
Case HP Coolant Units	HP coolant	C01129						
		100037280						
		100037281						
		C01130						

### 2.5 SHIPPING

Shipping method shall be as per GM GPSC requirements.

Unless otherwise directed by GM GPSC:

- The Supplier shall be the Exporter of Record
- The Supplier shall be responsible for all shipping documentation, import/export duties, taxes, and sea worthy packaging.

Supplier shipping costs shall be itemized in the quotation response as required in the GMPT provided Cost Breakdown Spreadsheet.



GMPT Document

GF6 F269 Transmission Case  
Machining**Supplier Compliance  
Confirmation**  
(YES – Comply)  
(NO - Deviation Request Required)

## 2.6 SELLER INSTALLATION AND COMMISSIONING SUPPORT

***GMPT is responsible for installation of the equipment.***

The Supplier must support this installation activity with supervision personnel. GMPT will install the equipment with the supervision of the supplier and based on the information provided by the supplier.

The Supplier shall provide a minimum of (2) mechanical and (2) electrical / software people per component on-site at each GMPT destination plant. Supplier's installation support personnel shall knowledgeable in the installation, set-up, and debug requirements for the equipment. It is GMPT's preference that Supplier installation support personnel be involved in the building, qualification, and pre-acceptance run-off of the equipment at the Supplier facilities. Supplier support personnel shall be prepared to work 10 hour shifts, 2 shifts per day, and six days per week. The additional details of the installation support plan will be determined during Design Concept Confirmation after the order is placed. A total of 4000 man-hours shall be quoted.

### 2.6.1 DESTINATION SITE LANGUAGE REQUIREMENTS

The Supplier shall provide all final machinery and equipment documentation delivered to the destination site(s) in the language(s) as specified below. All costs related to create and produce tags, signs, drawings, and documentation in the language(s) of the final destination site(s) for the equipment shall be included in the Supplier's quoted pricing. Supplier engineering and service personnel servicing the destination site(s) for the equipment shall be able to communicate in the listed specified language(s). English

## 2.7 CANADA TECHNICAL SAFETY AND STANDARDS AUTHORITY AND ESA COMPLIANCE

Equipment entering Canada must conform to the specifications of the TSSA (Technical Safety and Standards Authority) and ESA (Electrical Standards Authority). The TSSA specification requires inspection of and submitted reports for high pressure piping systems (high pressure coolant) and any air lines that are sized greater than  $\frac{3}{4}$ ". The details of this specification can be obtained from the website [www.tssa.org](http://www.tssa.org). Ontario Hydro approval is also required.

PSR (Pre-start Health and Safety Review) is also required for equipment going to Canada.

Each Piece of equipment must have an option pricing for TSSA, ESA, and PSR.

## 3.0 QUOTATION

### 3.1 "NO QUOTE" AND RETURN OF GMPT DOCUMENTATION

This SOR and associated documentation may disclose technical or other content of GMPT current or future products. Accordingly, should a Supplier elect to not submit a quotation to GMPT, this SOR package and associated documentation shall be returned to the GMPT Buyer along with a written explanation detailing the reason(s) why the Supplier has chosen not to quote.



<b>GMPT Document</b>	<b>GF6 F269 Transmission Case Machining</b>	<b>Supplier Compliance Confirmation</b> (YES – Comply) (NO - Deviation Request Required)
----------------------	---	--

**3.2 QUOTATION TIMING AND DELIVERY**

The Quotation Due date is set by GMPT Purchasing and will not change unless specifically communicated to all Suppliers involved in the quotation process. Dates are estimated per current status of the project at this time.

QUOTATION TIMING	DATE
<b>Supplier Line-Up Meeting</b>	TBD
<b>Clarification Meeting(s) (optional)</b>  <b>Location:</b>	As Necessary  GMPT Engine Engineering Building 823 Joslyn Avenue, Pontiac, MI 48340
<b>Number of Quotation Copies to Submit and Required Format:</b>	Three (3) complete hard copies & 3 complete sets of CDs

**3.2.1 QUOTATION CLARIFICATION MEETING(S)**

All questions and requests for clarification regarding this SOR, or any GMPT Specifications, shall be submitted via e-mail to the GMPT Manufacturing Engineer Primary Point of Contact listed above. Suppliers may be invited to attend Quotation Clarification Meeting(s) as deemed necessary by GMPT.

**3.3 REQUIRED WARRANTY**

The Supplier shall quote warranty of the system and equipment for a period of one (1) year beginning with the date of Start of Regular Production (SORP) for the equipment in accordance with GMPT Terms and Conditions (Refer to **SP-G-General** and **GPSC Terms and Conditions** for further warranty coverage requirements).

**3.4 SPARE PARTS**

Quoted as an OPTION, the Supplier shall provide replacement parts for the equipment during the warranty period. Replacement parts shall be delivered and received by the GMPT destination site within **twenty-four (24)** hours of notification by GMPT. The replacement parts shall be mutually agreed to by the Supplier and GMPT and total **two and one half percent (2.5%)** of the total purchase order contract. Spare parts shall be identified on the FM-G-BOM as spelled out in the FM-G-Technical Documentation list.

If the option is ordered, replacement parts may be reduced to less than 2.5% of the purchase order contract based on a detail review of the NEW material provided by the Supplier and of the current GM spare parts inventory available for the existing redepoly GM equipment.

The Supplier shall itemize the cost to stock replacement parts for both the base warranty period and any optional warranty period requested by GMPT in their quotation.

**3.5 PERISHABLE ITEMS**

It is the equipment supplier’s responsibility to ensure an adequate supply of replacement perishable items (for example: tools, seals, filter media, etc.) are available during installation, power on, debug, and PPAP, in addition to providing the full complement of perishable items required with equipment delivery. The following perishable items are required to be delivered with equipment delivery:



**GMPT Document**

**GF6 F269 Transmission Case Machining**

**Supplier Compliance Confirmation**  
(YES – Comply)  
(NO - Deviation Request Required)

**Cutting Tools:**

- 2 sets of Durable tooling (for example, tool holders, mill bodies for insert-style mills)
- 3 sets of Perishable tooling (inserts, drills, reamers, taps, etc)
  - SET is the material required for a complete assembly.
  - Quantities are PER SPINDLE.

**Part Touching details (in automation grippers, pallets, fixtures, etc):**

3 sets per UNIQUE part touching detail.

### 4.0 GMPT BASELINE REQUIREMENTS

#### 4.1 PRODUCT INFORMATION

Product design documents for quotation are provided for reference only. Detailed product information will be provided as available at the time of order confirmation.

GMPT shall make available to the selected equipment Supplier all available product models in Unigraphics format . It is the Supplier’s responsibility to subscribe to required web access service, or make arrangements with the service to obtain the data. This is Trubiquity for the suppliers. GM knows it as AutoWEB. The equipment Supplier shall have provisions in place at time of order to be able to use the data in the format provided by GM, with no impact on timing or cost.

Changes to the product design may require changes to the machinery & equipment during project implementation. These changes shall be documented and approved through the GMPT change management process at the time the change is identified.

The Supplier shall notify GPSC Buyer and the GMPT Manufacturing Engineer of an adjustment in price due to Product Engineering design changes. In the event that the Supplier fails to inform the GPSC Buyer and GMPT Manufacturing Engineer of the necessity for a price change within 24 hours of receiving notice of a product design change, the Supplier and GMPT agree that the design change is accommodated in the original amount of the Purchase Order agreement.

Workpiece Description	
<b>Product:</b>	Transmission Case (including Bushing assembly/machining)
<b>Material:</b>	Aluminum (refer to casting prints for detail material specifications)
<b>Hardness:</b>	Refer to casting prints material specifications
<b>Weight:</b>	Varies (refer to machining prints)
<b>Reference Drawing #s:</b>	Refer To Appendix A for detail list of all workpiece drawings

The manufacturing system supply shall include all tooling, software, and material handling necessary to machine the 6T40 and 6T45 Workpieces from Raw Casting Load until the High Pressure Deburr & Wash operation. The process steps are described in Appendix B.

The remaining workpiece drawing numbers provided as “REFERENCE & PROTECTION” shall be considered in the design of all machine fixtures, software, pallets, grippers, and material handling. The goal of this protection is to ensure manufacturing flexibility such that tools and cutting programs are the only changes required to produce the model.



GMPT Document

GF6 F269 Transmission Case  
MachiningSupplier Compliance  
Confirmation  
(YES – Comply)  
(NO - Deviation Request Required)

Sample workpieces (casting and machined parts) will be used to test compliance to this requirement during equipment qualification at the Supplier facility.

#### 4.2 MANUFACTURING SYSTEM REQUIREMENTS

MANUFACTURING SYSTEM REQUIREMENTS	
Equipment / Mfg. System Name	<i>Transmission Case Machining</i>
System Availability	85%
Actual Takt Time (seconds)	56 JPH
Maximum Cycle Time Per Line	219 seconds
Operating Plan	235 Days, 3 Shifts, 21.5 Hrs/Day
Minimum Stand Alone Machine Availability (%)	97%
Equipment Life (in years)	ten million cycles and ten years

(Refer to **SP-G-General** : Equipment Reliability & Maintainability)

**\*Cycle Time Note:** Maximum allowed cycle time is defined as the time between good part to good part at steady state condition (operation and/or line is not blocked or starved)

- System must be capable to machine all variants without manual changeover
- System must be capable to machine all variants in a batch size of one

#### 4.3 BASELINE PROPOSAL REQUIREMENTS

**IT IS MANDATORY THAT THE SUPPLIER SHALL QUOTE THE REQUIREMENTS OF THIS GMPT STATEMENT OF REQUIREMENTS (SOR) AS THEIR “BASELINE PROPOSAL”. FAILURE TO QUOTE THE BASELINE REQUIREMENTS WILL RESULT IN DISQUALIFICATION FROM ANY FURTHER CONSIDERATION ON THIS PROJECT.**

##### 4.3.1 Feature Charts

Feature naming convention is included in Appendix C.

##### 4.3.2 Manufacturing Process

Refer to Appendix B for a process flow diagram and to Appendix D for reference picture process sheets. The project goal is to replicate established processes from existing GF6 manufacturing locations in such combination to achieve quality and cycle time requirements. Use of this reference information in developing designs and process do not eliminate supplier responsibility; the supplier is fully responsible to provide a functional system that meets all safety, quality, and throughput requirements.

##### 4.3.3 Part Traceability / Identification

The manufacturing system shall include a system to apply and verify identification markings to the part (machine and human readable) within the location defined on the casting drawings. The baseline technology to apply the mark is dot-peen. A laser marker is also acceptable to use, provided it meets safety standards. Specific details and related specifications for the format and quality of the mark can be found in Section 7.10 of this document.

GMPT Document

**GF6 F269 Transmission Case Machining**

**Supplier Compliance Confirmation**  
(YES – Comply)  
(NO - Deviation Request Required)

The case castings have a binary coding feature—nibs / bumps. These shall be used as error proofing and identification of the casting upon loading to the system. The high level details of these features are shown on the following page. A sample photo of a nib reading mechanism and of the nibs (on a 6T40 Case) is shown below, only for reference and clarification.

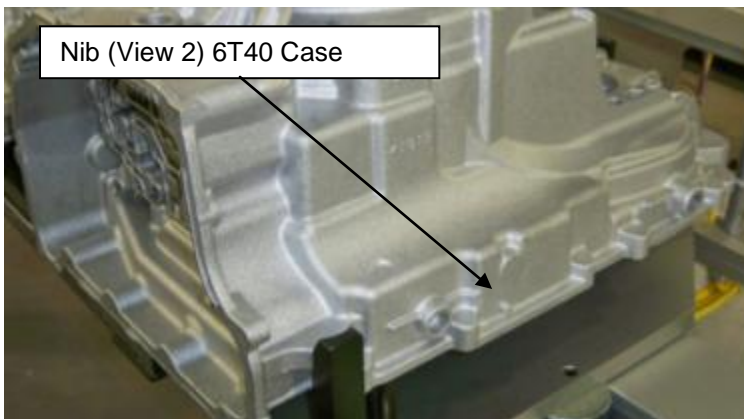
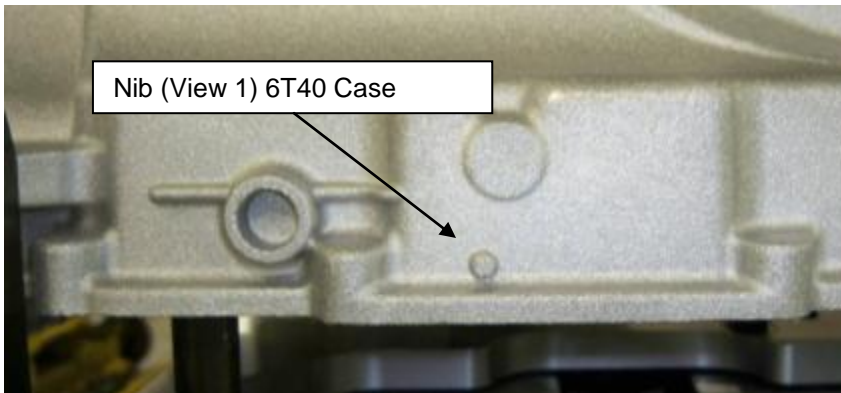
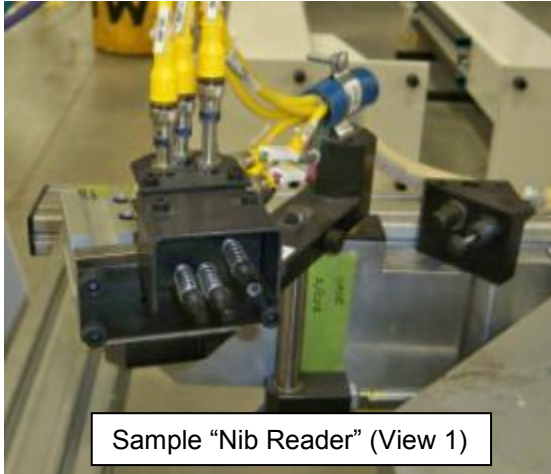

<b>GMPT Document</b>	<b>GF6 F269 Transmission Case Machining</b>	<b>Supplier Compliance Confirmation</b> (YES – Comply) (NO - Deviation Request Required)
----------------------	---	--

<b>GF-6 NIB MODEL TYPE BINARY CODING SYSTEM</b>												
POS. NO.	Marking code	NIB LOCATION							Part Number	CASE CONFIG.	COMMENTS	
		1	2	3	4	5	6	7				
A	A								● ●	24230711 or 24237194 or 24250640	X23 HD	6T45
B	B								●	24231894 or 24242248 or 24250637	X23 SD	6T40
C	C								●	24231615	X24	6T30
D	D								● ● ●	24240893	BAS+	BAS+

*Note: "●" denotes nib is present on casting*

To Valve Body Mounting Area (-V-)

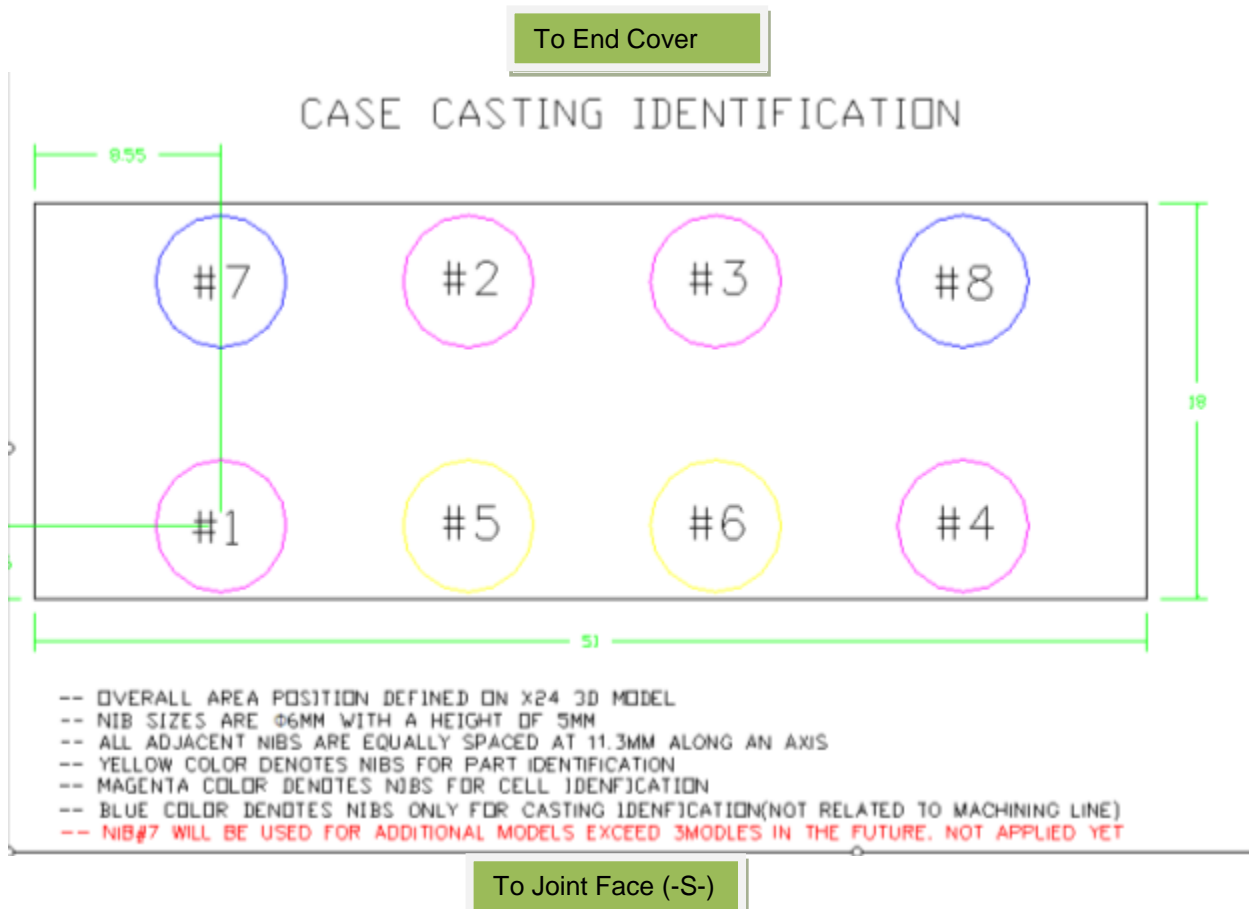



GMPT Document

**GF6 F269 Transmission Case  
Machining****Supplier Compliance  
Confirmation**  
(YES – Comply)  
(NO - Deviation Request Required)**4.3.4 Locating and Clamping**

Utilize CG lugs and/or Cast Datums for material handling, Cast Datums for Locating in OP10, Manufacturing Holes / Pads for all other operations. Primary clamping points shall be directly opposite locating points.

**4.3.5 Manufacturing Capability Requirements**

All Product Quality Characteristics (designated PQC on part prints) shall demonstrate a minimum 2.0 Cp and 1.67 Cpk during runoff and final acceptance. All other features (including Documentation Required-DR) shall demonstrate a minimum 1.67 Cp and 1.33 Cpk during runoff and final acceptance. The more stringent of these quality requirements or the information referenced in Section 7.7 shall be respected.

**4.3.6 Manufacturing System Architecture**

A concept system layout is included in Appendix E. The machining system shall be loaded manually, with automatic part transfer from the loading station through all operations to the point of transfer from machining operations to the deburr/wash operation. The loading area shall have capacity for an operator to load a minimum of six pieces before releasing the lot to the automatic station. The machine-to-machine automation baseline concept is overhead robot(s) on moving carriers.

System shall be flexible for quick change (automatic) robot part grippers, including “park” stations for maintenance of the robot.

Robots will be supplied by General Motors. The robot selection process will be followed (refer to Robot application specification), a joint effort between the Supplier, Fanuc, and GM. General Motors supplies the robots only—end of arm tooling, additional protection (for application), and integration are the responsibility of the selected supplier. There are some existing robots available for re-use, however if those robots are not heavy duty enough, new robots would be provided.

The machining system must communicate part status and other information necessary to integrate with the deburr/wash system.

Provision must be made for safely unloading and loading partially finished parts (in-process workpieces).

All Automation and Machines shall be DRY FLOOR compliant. Provisions to automatically drain accumulated fluid (from trays, pans, etc) shall be included.

**4.3.7 Special Machine (Bushing Press)**

Reference designs of existing Case bushing press machines can be found in Appendix F. Use of these drawings and information do not change the requirement for the supplier to provide a functional system that meets all safety, quality, and throughput requirements. In addition to the requirements in the GM Specifications for new equipment applied to this project, the machine shall have the following features:

- Integration with plant and system andon and control
- Automatic feeding system for bushings to press mandrel
- Capability for periodic measurement of the bushing bore diameter (pre-assembly)—for example, auto gaging station in press with mastering/verification capability. Measurement of bushing bore diameter must be completed (whether automatic or manual) without the need to lockout the machine.
- Force and distance monitoring and control capability (recommend Promess EMAC system)

GMPT Document

GF6 F269 Transmission Case  
MachiningSupplier Compliance  
Confirmation  
(YES – Comply)  
(NO - Deviation Request Required)

#### 4.3.8 Machine Requirements

Include probing system (Renishaw or equivalent) hardware and software.

High Pressure Coolant filtration to 30 micron absolute particle size or spindle/coupling/machine system application requirements (whichever is more stringent).

Include Tool ID memory tag read capability for conveying tool offsets and error-proofing information.

Include non-contact broken tool detection capability, however the project goal is to utilize existing hardware in the machines.

Machine structure / guarding / plumbing (coolant, hydraulic, pneumatic, etc) / access doors may require re-design to accommodate the system layout. Existing machines have individual coolant pumpbacks in front, and parts are loaded through side access doors. The new system concept is top or front load for automatic and front load for manual. Coolant should be routed to the ends of the cell in a manner that does not interfere with part loading.

#### 4.3.9 Tool Path Part Programming Requirements

Part programs and offsets shall be compatible with GM's COMP tool. Refer to Section 7.10 for more details.

#### 4.3.10 Part Fixturing Concepts and Requirements

Reference 3D models of GF6 Fixtures are included in Appendix G, and reference detail drawings are included in Appendix H. These can be used as a baseline only for initial process analysis, as the supplier is fully responsible to provide a function system that meets safety, quality, and throughput requirements. The following design elements shall be incorporated with this project, unless a deviation is approved in writing (refer to the deviation process and forms).

- 1) A GM Standard Fixture plate shall be included between the machine and the fixture. The hole pattern and definitions are included in Appendix I. The detail design between the machine and fixture plate shall be developed by the supplier.
- 2) Established GF6 work support methods (in addition to part clamping) shall be followed, with engineering analysis completed to identify additional needs based on Machine-Fixture-Part interaction and cutting loads (Finite Element Analysis).
- 3) Clamping Power shall be hydraulic.
- 4) Push-Pull Block included for Diamond Locating Pin Adjustment.
- 5) Broken fixture pins are detected by means of a closed circuit (coolant or air) that will become open in the event of a broken pin—refer to the example below. The circuit shall be monitored automatically to detect an abnormal condition.

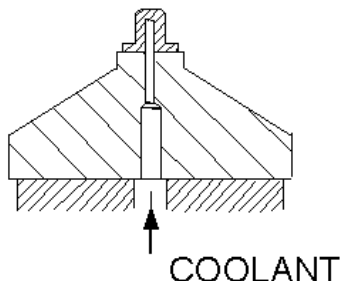

## GMPT Document

GF6 F269 Transmission Case  
Machining

**Supplier Compliance  
Confirmation**  
(YES – Comply)  
(NO - Deviation Request Required)

- 6) Part Seated Detection shall be capable to detect a gap of 0.025-0.050mm between the workpiece and any one of the locating pads. After load, if the fixture air part seated check detects an error in the locating interface, the machine will initiate an unclamp and re-clamp cycle. If this is unsuccessful, the machine will then prepare for the manual intervention and call (via Andon and stack light) for operator assistance to clear the fixture. To continue production, the operator shall only need to confirm part OK and (after manual cleaning of fixture and loading the part) restart the machine
- 7) Verification / setup device for Part Seat Detection shall be included in the fixture design.
- 8) Part Seated Detection shall be monitored throughout the machining cycle.
- 9) Chip Flush (coolant) is required for each rest pad. If possible incorporate coolant through rest pad (separate hole from air part seat detect passage)—for example, see illustration below.

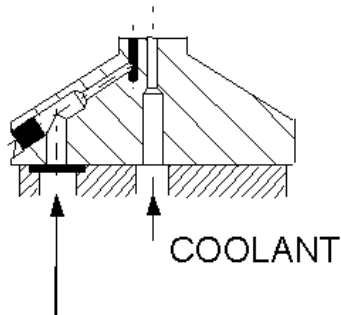

## PROVISION FOR AIR

- 10) Use positive mechanical motion to remove part from fixtures (no gravity).
- 11) Sequencing Valves are allowed for secondary motions (work support lock, crowding, etc). Multiple hydraulic circuits should be used to maintain specific clamp sequences and timing.
- 12) Cutting force should be applied toward fixed locators (not clamp arms) as much as possible (to be reviewed during detail design phase).
- 13) Clamps should be applied directly opposite fixed locating pads.
- 14) Clamp position shall be monitored for over/under travel of clamping arms.
- 15) Clamp force shall be designed such that the resultant frictional force (workpiece-fixture) is a minimum of three times greater than the maximum cutting force resultant parallel to the machined face.
- 16) Overall fixture design shall incorporate angled surfaces, flushes, and clearances to prevent chip or coolant accumulation.
- 17) The fixtures shall include qualified surfaces to use for alignment and probing in the machine (Linear and Rotary Axes).
- 18) Fixtures shall include hard-piped coolant lines or internal passages to be used for flushing.
- 19) Flush lines shall use nozzles, the spray style shall be fitted to the application (example: cone pattern for locators, fan pattern for part).
- 20) Switches and Sensors must be waterproof and protected from chips.
- 21) Fixture pads shall have minimum hardness Rockwell C 58-60.
- 22) All Fixture seals shall be Viton.



GMPT Document

GF6 F269 Transmission Case  
Machining**Supplier Compliance  
Confirmation**  
(YES – Comply)  
(NO - Deviation Request Required)

#### 4.3.11 Tooling Concept and Requirements

Reference Tool Layouts and Material Lists are included in Appendices J & K. The project shall incorporate tool designs and components from the Appendix J Layouts to the greatest extent possible. For Cycle Time savings, some tools in Appendix K have been identified for application to this process.

Any new tooling concepts or designs shall comply with all applicable GMPT specifications.

#### 4.3.12 Error Proofing Features

The system shall include error-proofing features to correctly identify the part type/model and NC program for each operation.

All parts shall be checked for presence (100% inspection) of the bushing after exit from the Bushing Press machine and before being unloaded to the wash station.

### 4.4 GMPT REQUESTED OPTIONS TO BASELINE PROPOSAL

#### 4.4.1 Manual System Option:

A reference / sample layout for conceptual purposes is included in Appendix L. For this option, all stations are manually loaded and unloaded in a U-Cell Configuration. Part Transfer between stations will be achieved manually (no powered conveyors).

The scope of supply is from system load to deburr system loading; the part must be positively located with precision sufficient to allow reliable pickup by a robot or equivalent automation.

Special care must be followed for ergonomics consideration. Refer to the Ergonomics specification on the project for more details (SP-S-Safety & Ergonomics G2.0). The work envelope shall meet the combination of horizontal reach less than 380mm (from outer surface edge to the palm of the hand) and vertical reach between 950-1100mm (from floor to working area on the part). This work envelope shall include the "cycle start" device.

#### 4.4.2 Gantry Style Automatic System Option

Rather than use GM provided robot for automation, the supplier may quote as an option a gantry system for load/unload of the machining centers. For this option, the supplier is fully responsible to provide a working system

### 4.5 SUPPLIER REQUESTED OPTIONS OR ALTERNATES

Supplier alternate proposals must be identified as "Alternates to Baseline Requirements" and quoted and listed separately from the Baseline Proposal with the same level of information detail, and in the same format, as the Baseline Proposal. For alternate proposals the Supplier shall include the cost and schedule impact of implementation on the project as compared to the Baseline Requirements.

### 4.6 QUOTATION DELIVERABLES

The Supplier shall submit all Quotation deliverables as specified in this SOR, as required by GMPT specifications, and as listed on GMPT form **FM-G-Technical Documentation**, to GPSC with the Supplier's quotation.

Refer to Appendix M for the Cost Breakdown Spreadsheet (Requirement 1.5 from Group 1-Quotation in the FM-G-Technical Documentation form).

Requirement 1.3 (from Group 1-Quotation in the FM-G-Technical Documentation form) Clarification:

Cycle Time diagram must be detailed by each machine and tool, and by automation steps.



<b>GMPT Document</b>	<b>GF6 F269 Transmission Case Machining</b>	<b>Supplier Compliance Confirmation</b> (YES – Comply) (NO - Deviation Request Required)
----------------------	---	--

**4.7 TECHNICAL DATA TO SUPPORT EXPORT CLASSIFICATION OF MACHINERY AND EQUIPMENT**

The products, services and / or technical data (hereinafter referred to collectively as “items”) to be delivered under this RFQ may be subject to U.S. export control laws and regulations and / or export laws of other countries. The Supplier agrees to comply with all such laws and regulations and agrees to obtain all necessary authorizations to export, re-export or import such items, as may be required by such laws and regulations.

GM is providing four templates in order to obtain the necessary Technical Data based on the type of equipment sold to GM. GM requires the Technical Data for each different machine model sold to GM. GM assumes that the Technical Data does not vary from machine to machine within a model. If that statement is true, then only one template is required for each model of machines sold to GM. In addition, under the US Export Administration Regulations (EAR), the Export Control Classification Number (ECCN) associated with the hardware, software and /or technical data is to be provided by U.S. Suppliers.

Please refer to the following templates located in the Project SOR package issued with the SOR:

- FM-G-CNC-Export-Compliance*** (for CNC Machines)
- FM-G-CMM-Export-Compliance*** (for CMM machines)
- FM-G-Robot-Export-Compliance*** (for Robots)
- FM-G-Misc-Export-Compliance*** (for Miscellaneous Equipment)

**4.8 SUPPLIER PROJECT PLAN**

The Supplier shall provide their Project Plan per the requirements of GMPT ***SP-G-General*** specifications.

**4.9 SUPPLIER INITIAL PRICING SPREADSHEET**

The Cost Breakdown Spreadsheet must be completed and submitted with the quotation, the form is found in Appendix M.

**4.10 PROJECT QUALITY REQUIREMENTS**

If the Supplier determines that part tolerances at required quality levels, or other requirements identified, are unobtainable, these shall be identified in writing as part of the Supplier’s quotation.

- Detail quality requirements are found in the Machine Runoff specifications and in Section 4.3.5 of this document.
- Supplier shall demonstrate the ability of the system to meet all part print requirements. The Supplier shall provide measurement results from a certified inspection facility for all part print features on at least one piece from the capability test.
- Since these machines are being retooled, consideration for the quality requirements for the features cut in a given machine should be given when evaluating retool requirements. A roughing or drill/tap operation may not need the same level of rework as a finish operation where tighter tolerances are required.
- The Supplier shall identify its measurement system capability to be used during setup and qualification at its facility. The coordinate measuring machine (CMM) shall make use of General Motors (GM)-Provided and designed part holding fixtures, probe tooling, and measurement programs. The CMM must include the CETC CMM Software Build-Calypso including GM version GSOI, & Qs-stat. Programs are written with Calypso software version 4.6.10.23XXX. Any alternatives must be reviewed and mutually beneficial for the Supplier and GM. This GM equipment (or equivalent) will be intended for use at the GM facility for monitoring production results. The



GMPT Document

GF6 F269 Transmission Case  
MachiningSupplier Compliance  
Confirmation  
(YES – Comply)  
(NO - Deviation Request Required)

Supplier shall have on-site capability of performing general CMM system support ie; making minor CMM program modifications, calibrating probes, recovering from collisions etc.

#### 4.11 ENVIRONMENTAL REQUIREMENTS

Refer to **SP-G-General** for general environmental requirements that must be met for all projects.

### 5.0 PROJECT ENGINEERING AND IMPLEMENTATION

This section describes the basic equipment design requirements and project management methodology to be adhered to by the Supplier in implementing GMPT projects. The requirements and services described here are required to be provided by the Supplier and are common to all GMPT projects. The Supplier is responsible to adhere to all GMPT Specification requirements and perform timely completion and submittal of all required GMPT Project deliverables. (Refer to GMPT Specifications for further information)

#### 5.1 CONCEPT DESIGN CONFIRMATION (SE PHASE)

1. Review the equipment, or system, design and the Supplier's Detailed Price Breakdown Spreadsheet. GMPT and the Supplier shall identify opportunities for cost, performance, and quality opportunities for improvements. Approval for implementing identified opportunities for improvement shall be made in full compliance with GMPT change management procedures.
2. Review and Detailed Project Schedule. Project management tracking methods, frequencies, specific to the project shall be defined.
3. Evaluate part print revisions for engineering and material costs or savings.
4. Develop and review locating plans, fixture, and tooling concepts. The Supplier shall develop tooling proposals that include tooling costs, estimated tool life, etc. for each tool. All concepts and proposals shall be reviewed and approved by GMPT.
5. Develop and Review tool path part programs, including the implementation of COMP.
6. Develop and Review system flexibility design features.
7. Finalize the selection of subcontractors and sub-suppliers to be used on the project and review their selections with GMPT for agreement.
8. Review the Supplier's M-FMEA for the equipment and finalize the equipment functional requirements. Automation and associated equipment requirements shall be included in the reviews. As deemed necessary by GMPT, the Supplier shall participate in Design for Manufacturing (DFM) / Design for Assembly (DFA) workshops, simulation workshops utilizing Supplier provided information (MTTR, MTBF), and other design studies to identify potential design improvements to be made to the equipment. The Supplier shall also review and support GMPT in development of the Process (P)-FMEA and Control Plans for equipment and system integrity.
9. Review the Supplier plans for order and delivery of long lead time equipment components.
10. Develop the Error Proofing and Traceability requirements for the equipment.
11. Review Andon requirements (see section 7.15)
12. Develop the controls architecture for the equipment, and the integration of the equipment within the GMPT manufacturing system including development of common software memory maps for the equipment. Initiate planning for equipment Pre-acceptance Runoff at Supplier, and Final Acceptance at the GMPT destination site. The plan for order and delivery of sample, tryout, and runoff production parts, gauging methods, acceptance requirements, and personnel requirements shall be determined.
13. Review concepts for machine design, disassembly, shipment, and installation to facilitate the rapid installation of the equipment at the GMPT destination site. The review shall identify opportunities such as mounting peripheral



GMPT Document

GF6 F269 Transmission Case  
MachiningSupplier Compliance  
Confirmation  
(YES – Comply)  
(NO - Deviation Request Required)

equipment integral to the machine to facilitate equipment installation. Where integral mounting is not possible the Supplier shall employ modular and quick-connect type methods approved by GMPT.

14. Develop detailed equipment and system layouts including all support equipment, and work with GMPT layout engineering departments on plant layouts. The Supplier shall work with GMPT to determine a common drop area for mechanical and electrical utilities; and the main lockout points for each piece of equipment. All common drop locations shall be submitted for approval by GM Plant Engineering/Layout. A scaled detailed equipment installation drawing consisting of equipment anchoring details, utility drop locations, and equipment lockout points shall be submitted to GMPT Engineer before equipment build and followed up with a verified “as-built” revision delivered to GMPT before equipment teardown for shipment.
15. Reduce Energy Usage of the equipment and support systems by implementing Minimum & Maximum Energy Conservation Modes, Implement Coolant Conservation methods, Reduced Air Consumption, Include Dirty Air Filter monitoring switches, and Provide Air Consumption measurements.
16. Review the Machine Data Spreadsheets, *FM-P-Mach Data (FM-P-Utilities Information, FM-P-Engr Install Data)* Forms, with GMPT. The information shall be regularly maintained and updated by the Supplier for all equipment and submitted to GM Plant Engineering at a frequency as required by GMPT Plant Engineering.
17. For applications using machining coolants - review the coolant management and conservation concepts and plans for the equipment with GMPT. The Supplier shall develop concepts and designs for pumpback and coolant / chip conveyance, flow and filtration requirements, high pressure coolant usage, conservation valving, and containment of coolant and mist.
18. Review *FM-G-Training Summary* to begin development of training requirements and plan.
19. Develop the plans for warranty and service needs including such items as equipment installation support, spare parts, part exchange procedures for warranty items, stocking locations for potential warranty materials, etc.
20. New Equipment utilizing computers (those applications that **can not** be PC less) shall follow the given parameters and utilize the most current Memory Map:

Processor Speed – Sufficient to run Controls Program(s) at no more than 25% CPU Utilization

- RAM Memory – Minimum 2GB (no more than 50% RAM usage with all programs running)
- Drive Storage – Free Space on System Drive Partition at Delivery – 50% of drive space or 1GB whichever is greater
- CD Drive
- USB Port(s) accessible from front panel
- Windows XP Service Pack 3
- McAfee VirusScan Enterprise 8.5 configured for GMPT Controls.
- Current Applicable Microsoft Security Patches
- Solidcore Version: 4.6.5-2209
- Upload, Download & Compare (UD&C) Software
- Backup Software - Acronis Workstation True Image Version 9.1 build 3946

## 5.2 “IN-PROCESS” REQUIREMENTS AND DOCUMENTATION

The Supplier shall determine final tolerance stacks to meet part print requirements. This includes the development of “in-process” dimensions and tolerances based upon limit stacks. The final tolerance stacks shall be reviewed and approved by GMPT.



GMPT Document

GF6 F269 Transmission Case  
MachiningSupplier Compliance  
Confirmation  
(YES – Comply)  
(NO - Deviation Request Required)

### 5.3 REBUILD AND REHABILITATION REQUIREMENTS

All equipment requiring rebuild or rehabilitation shall be renovated by the Supplier to meet the System Availability and machine Stand Alone Availability specified in the SOR and GMPT specifications, utilizing components and systems according to the GMPT recommended components.

Unless otherwise specified by the User in the SOR all equipment requiring rebuild or rehabilitation shall be renovated by the Supplier to meet current GMPT Safety Specifications SP-S-Safety & Ergonomics. The itemization of costs for rebuilding equipment shall be detailed on the Initial Pricing Spreadsheet and Detailed Cost Breakdown Spreadsheet forms provided by the User.

**NOTE:** Short circuit Slash-rated components (480/277Volt) shall not be used. The plant power distribution systems include Delta-ungrounded and Wye-Star-Resistive-Neutral, and these systems require either straight-rated components (480V), or machine isolation transformers. Retooled machines with slash-rated components shall include machine isolation transformers, or shall replace slash-rated (480/277) components with straight-rated (480) components.

1. Receive and clean machinery and equipment.
2. Clean, flush, inspect and test all hydraulic, pneumatic, lubrication and coolant systems including pumps, tanks, valves, distribution blocks, lines, piping, tubing, etc.
3. Repair all leaks, including hydraulic, pneumatic, lubrication and coolant.
4. Inspect all motors for vibration, wear, noise, and current draw. Replace motors that do not meet specifications.
5. Replace all filters on hydraulic, pneumatic, lubrication and coolant systems.
6. Replace pressure switches (i.e. Vogel) and flow switches with IFM Efeclor switches.
7. Replace all damaged field wiring. Replace all damaged raceways, enclosure wiring, enclosure doors and enclosures.
8. Replace the electrical control system components that cannot be supported (become mature and/or obsolete) for at least five years after start of regular production (SORP), or are not readily available. See Flow Chart after section 10.
9. Electrical components shall be inspected for functionality. Defective components, damaged raceways, enclosure wiring, enclosure doors and enclosures shall be replaced as needed.
10. Replace all batteries in all components, including but not limited to controllers, drives, position feedback devices, Uninterruptable Power Supplies (UPS) controllers, etc.
11. Replace any Honeywell safety gate switches with Euchner. Quote as a line item.
12. Replace any and all General Electric relays and contactors with approved components.
13. Replace any General Electric variable frequency drives model numbers AF300E\$ with approved components.
14. Replace all NT platform frontends with current components from appropriate Project books.
15. Replace any Xycom and Nematron computers (the computers shall be salvaged and returned to General Motors).
16. Remove SOI (Hughes Standard Operator Interface) on CNC PC's, and replace with appropriate HMI screens and PM&C/Andon Interface mechanisms to meet the specifications.
17. Replace any 'Open Control' machine control software with PLC/HMI as listed in the approved components book for the project.

**GMPT Document****GF6 F269 Transmission Case  
Machining****Supplier Compliance  
Confirmation**  
(YES – Comply)  
(NO - Deviation Request Required)

18. Upgrade PC controlled machines to a PLC and one of the non-PC based operator interfaces, listed in the F269 project books. Field and Panel I/O only requires upgrade if necessary to meet the above requirement
19. Update machine to current GMPT Safety specifications including Dual Channel Safety circuits, guarding, etc.
20. All machines shall be labeled according to the UL508A-SB standard for Short Circuit Current Rating (SCCR).
21. Inspect & Replace all damaged way wipers and way covers throughout the machine. Use components of similar or better quality than originally supplied. New components shall be as specified in current GMPT Specifications.
22. Parts that are worn beyond reuse due to abnormal wear, and must be replaced, shall be quoted after inspection and approval by the GMPT Manufacturing Engineer and Purchasing M&E Buyer. This applies to those parts, other than those included and described in the base quote. See Flow Chart after Section 10.
23. Assemble and paint new components or sections of the machine having missing or damaged paint
24. Demonstrate performance to GMPT Specifications.
25. Prepare machine for shipment per GMPT Specifications and requirements.
26. Complete documentation shall be provided. Base existing machine/controls drawings will be provided as reference, and may be updated and returned, but a complete drawing package (including any missing sheets) is the responsibility of the supplier to provide.
27. In the case of the pneumatics lockout, move all lockout devices to before the drip leg. (St. Catharines plant requirement)

#### 5.4 INTERFACING TO AUTOMATION, EQUIPMENT, OR SYSTEMS PROVIDED BY OTHERS

5.4.1 In operations that provide multiple and or redundant systems (examples include dual robot cells and dual gantries...etc), each system shall be flexible enough to operate partially and or independently of each other. This shall be achieved by moving the non-operational or idle component ( robot or gantry) to a designated and known safe location as required by the specific application. The system shall then have a bypass mode that allows the rest of the system to operate as normal until which time the idled equipment can be brought back online. The operator shall be able to select this from the HMI.

In operations that include multiple input and or output streams (examples include robots, conveyors, gantries, buffer systems...etc), each system shall be flexible enough to operate partially and or independently of each other. For example a robot loading (4) outgoing conveyors shall have the capability to load any combination of the (4) with the others left in idle bypass mode. The operator shall be able to select this from the HMI.

The operator shall have ability to load and unload parts in-process and return them to the system for completion of all remaining steps.



GMPT Document

GF6 F269 Transmission Case  
MachiningSupplier Compliance  
Confirmation  
(YES – Comply)  
(NO - Deviation Request Required)

## 6.0 GMPT PROVIDED ATTACHMENTS

Refer to the Appendices (separate documents and files)

Appendix A	Part Number Lists, Reference Part Drawings (sketches)
Appendix B	Process Flow Description
Appendix C	Feature Naming Charts
Appendix D	(two zip files) Reference Picture Process Sheets (6T40/6T45)
Appendix E	Automatic System Concept Layout
Appendix F	Reference sketches bushing press machine
Appendix G	Reference 3D models of fixture concepts
Appendix H	(four zip files) Reference sketches of fixture concepts
Appendix I	GM Standard Fixture Plate Definition
Appendix J	(six zip files) Reference Tool Layouts from existing process
Appendix K	Tooling Recommendations for Cycle time
Appendix L	Manual System Concept Layout
Appendix M	Cost Breakdown Worksheet

## 7.0 GMPT PROJECT SPECIFICATIONS

The authorized set of Buyer's Standards and Specifications applicable to this Project are published on the *GM SupplyPower* internet site in the **ME CETC Global Specifications Library** folder. The following listed Standards and Specifications apply to this SOR as known at the date of issue of this SOR. Prior to award of contract, and based on technical evaluation of the Supplier quotation responses, Buyer may determine that additional Buyer Specifications and Standards are applicable and shall apply to this project. In such cases Buyer shall provide the Supplier of additional specification requirements in writing before award of the contract.

After award of contract any change, addition, or deletion of Buyer's Standards and Specifications as agreed to at time of contract award shall be in full compliance with Buyer change management procedures.

### 7.1 GENERAL PROJECT SPECIFICATION

<b>General Project Specification</b>	<b>SP-G-General</b>	<b>2010-01-08</b>	<b>G2.0</b>	_____
<b>Technical Documentation</b>	<b>FM-G-Technical Documentation</b>	<b>2008-09-19</b>	<b>G1.0</b>	_____

Update technical documentation required to accommodate the retool requirements.

Any missing technical documentation needs to be provided according to the global specifications.

SP-G-General G1.0 Addendum (replacement):

#### Section 4.4 GMPT PROVIDED MATERIAL AND EQUIPMENT

- The Supplier shall provide GMPT timely notification of when delivery of GMPT provided materials and equipment such as, production parts, robots, tooling, CMMs, and gaging, are required by the Supplier in order to meet the project schedule.
- Upon delivery by GMPT, and its' agents, the Supplier shall assume full responsibility for all GMPT provided materials and equipment to the final destination named by GMPT (including Customs clearance, duties, taxes, insurance, and transportation costs).



<b>GMPT Document</b>	<b>GF6 F269 Transmission Case Machining</b>	<b>Supplier Compliance Confirmation</b> (YES – Comply) (NO - Deviation Request Required)
----------------------	---	--

- The Suppliers' responsibility extends to timely transportation and management at subcontractor and sub-supplier facilities. The Supplier shall adhere to all GMPT required security precautions.
- All GMPT production parts, materials, gages, CMMs, tooling and equipment provided to the Supplier shall be returned to GMPT at completion of the project per written instruction provided by the GMPT Manufacturing Engineer.

## 7.2 SAFETY & ERGONOMICS SPECIFICATION

<b>Safety &amp; Ergonomics Specification</b>	<b>SP-S-Safety &amp; Ergonomics</b>	<b>2010-01-08</b>	<b>G2.0</b>	_____
<b>GM Global Design for Health &amp; Safety Standards</b>	<b>G-DHS-2</b>	<b>2007-02-02</b>	<b>G-DHS-2</b>	_____
<b>GM Sound Level Specification for the Purchase of New and Rebuilt Machinery, Power tools, and Equipment</b>	<b>GM-1619 (GM Specification SL1.0)</b>	<b>1997</b>	<b>Ver 1</b>	_____

### 7.2.1 ASSEMBLY SYSTEM ERGONOMIC LINE HEIGHT

## 7.3 MAINTENANCE SPECIFICATION

<b>Maintenance of Machinery &amp; Equipment Specification</b>	<b>SP-G-Maintenance</b>	<b>2010-01-08</b>	<b>G2.0</b>	_____
<b>GM Vibration Standard For The Purchase Of New And Rebuilt Machinery and Equipment</b>	<b>GM 1761 - Vibration Analysis</b>	<b>2005-04-29</b>	<b>Ver 2.0</b>	_____
<b>GM Laser Alignment Specification For New And Rebuilt Machinery and Equipment</b>	<b>GM 1907 - Laser Alignment</b>	<b>2006-03</b>	<b>Ver 4.0</b>	_____

### 7.3.1 PREDICTIVE MAINTENANCE TECHNOLOGIES

#### 7.3.1.1 VIBRATION ANALYSIS REQUIREMENTS

Maximum allowable vibration limits for all machinery and equipment components shall be within the Vibration Limit Levels specified within GM Standard 1761 - Vibration Analysis. All applications exceeding the specified Vibration Level Limits shall be reviewed with GMPT and require approval by the responsible GMPT Manufacturing Engineer.

When the SOR requires the Supplier to perform Vibration Analysis on the equipment the analysis shall be performed in accordance with GM Standard 1761 - Vibration Analysis.

Where the Supplier is required by the SOR to design and build routine preventive maintenance vibration analysis capability into the equipment the design and implementation shall be in accordance with GM Standard 1761 - Vibration Analysis. (Refer to GMPT Specification **SP-G-Maintenance** and **GM Standard 1761** for further requirements.)

Baseline vibration analysis signatures shall be completed prior to shipping equipment from supplier's facility and the data transferred to the designated General Motors representative.



GMPT Document

GF6 F269 Transmission Case Machining

Supplier Compliance Confirmation (YES – Comply) (NO - Deviation Request Required)

7.3.1.2 LASER ALIGNMENT REQUIREMENTS

Laser Alignment of critical machine components as specified in this SOR shall be performed in accordance with GM Standard 1907 - Laser Alignment. (Refer to GMPT Specification SP-G-Maintenance and GM Standard 1907 for further requirements.)

Alignment and geometry checks shall be performed to evaluate the condition of the machine.

Including:

- Spindle-X Axis Perpendicularity (over machine stroke)
Spindle-Y Axis Perpendicularity (over machine stroke)
X-Z Axis Perpendicularity (over machine stroke)
X-Y Axis Perpendicularity (over machine stroke)
Y-Z Axis Perpendicularity (over machine stroke)
X Axis Straightness (horizontal and vertical, over machine stroke)
Y Axis Straightness (horizontal and vertical, over machine stroke)
Z Axis Straightness (horizontal and vertical, over machine stroke)

7.3.1.3 Infrared/Thermal Vision Inspection

(Refer to GMPT Specification SP-G-Maintenance for further requirements.)

Inspection shall be completed at OEM site for applicable machine systems (especially electrical cabinets), and again after installation at the GM facility, prior to final acceptance.

7.4 DRAWING SPECIFICATION

Table with 5 columns: Manufacturing Drawing Specification, SP-G-Drawing, 2010-01-08, G2.0, and a blank column.

SP-G-Drawings Specification Addendum (additional):

- If for any retooled/refurbished machinery and equipment there are missing drawing packages/sheets (i.e. master files not provided with what is to be retooled/refurbished), then the Supplier must create the required drawing packages/sheets that are missing in order to provide a complete equipment drawing set as described in SP-G-Drawing under sections "Complete Equipment Drawing Set" & "Bill of Material (BOM)."
- All controls drawings for new and re-tooled equipment must be provided in AutoCAD® with ANSI / NFPA Device Identifiers. (Does not apply to Assembly)



GMPT Document

GF6 F269 Transmission Case  
MachiningSupplier Compliance  
Confirmation  
(YES – Comply)  
(NO - Deviation Request Required)

## 7.5 TRAINING SPECIFICATION

Training Specification for Mfg./Assy. Systems and Equipment	SP-G-Training	2010-01-08	G2.0	_____
GM Technical Manual Specification for Equipment & Manufacturing Systems	GM TMS-1	2005-08-01	Ver 4.0	_____
General Motors Corporation Material Safety Data Sheet Information Requirements	GM TMC003	2005-04	None	_____

## 7.6 LAYOUT SPECIFICATION

Plant Layout Requirements	SP-L-Layout	2010-01-08	G2.0	_____
---------------------------	-------------	------------	------	-------

## 7.7 QUALITY PRE-ACCEPTANCE AND FINAL ACCEPTANCE RUNOFF SPECIFICATION

Machining and Assembly Runoff and Acceptance Specification	SP-Q-MARO	2010-01-08	G2.0	_____
Test Method to Quantify Cleanliness of Powertrain Components	GMW 16037	July 2009		_____

GMW 16037 Test Method to Quantify Cleanliness of Powertrain Components replaces GMN 6752 Test Method To Quantify Foreign Material referenced in SP-Q-MARO Section 3.4.3.12.1.

## 7.7.1 QUALITY PRE-ACCEPTANCE AND FINAL ACCEPTANCE RUNOFF PLAN

The Supplier shall adhere to the Pre-acceptance and Final Acceptance Runoff Plan as specified in this SOR. The applicable requirements and procedures of the plan shall be performed in accordance to GMPT Specification **SP-Q-MARO**, and as additionally specified in GMPT specifications for the type of equipment purchased.

## 7.7.1.1 EQUIPMENT PRE-ACCEPTANCE RUNOFF PLAN AT SUPPLIER FACILITIES

All MARO requirements as stated in retool SOR will be applied to the retool equipment runoff. The AP & Fixtures become an integral part of that activity. Failure to meet runoff requirements at the retool OEM may cause design OEM to participate in engineering solution meetings with GMPT.

## 7.7.1.2 EQUIPMENT FINAL ACCEPTANCE RUNOFF AT GMPT DESIGNATION FACILITIES

All MARO requirements MUST be met for qualifications at GMPT site as part of the retool project. AP & Fixtures will be integral elements of that activity.

## 7.8 MEASUREMENT SYSTEMS APPLICATION SPECIFICATION

Measurement Systems Specification	SP-Q-MSS	2010-01-08	G2.0	_____
-----------------------------------	----------	------------	------	-------



GMPT Document

GF6 F269 Transmission Case  
MachiningSupplier Compliance  
Confirmation  
(YES – Comply)  
(NO - Deviation Request Required)

## 7.9 GAGE AND COORDINATE MEASURING MACHINE (CMM) SPECIFICATION

Gage Computer and Statistical Software System Specification	SP-Q-GCR	2010-01-08	G2.0	_____
CMM Application Specification	SP-Q-CAS	2010-01-08	G2.0	_____

## 7.10 ELECTRICAL CONTROL SPECIFICATION

Electrical Specifications-Supplement to IEC 60204-1	SP-E-60204	2010-01-08	G2.0	_____
Human Machine Interface Specification	SP-E-HMI	2010-01-08	G2.0	_____
Assembly System Controls Requirements	SP-E-Assembly Controls	2010-01-08	G2.0	_____
Manufacturing Networks Implementation Requirements	SP-E-Networks	2010-01-08	G2.0	_____
Robot Process & Simulation, Integration & Programming Specification	SP-E-Robot Integration	2010-01-08	G2.0	_____
Interface Definition Requirements	SP-E-Interfaces	2010-01-08	G2.0	_____
Direct Part Marking & Validation	SP-E-DPM	2010-01-08	G2.0	_____
Machining System Control Requirements	SP-E-Machining Systems	2010-01-08	G2.0	_____
Memory Map Specification	SP-E-Powertrain Memory Map	2010-01-08	G2.0	_____
Agile CNC Programming Requirements	SP-E-Agile CNC Programming	2010-01-08	G2.0	_____

SP-E-60204 Specification Addendum:

## Section 4.3 Electrical Supply

- Mains surge suppressors shall be provided (i.e. MVC, etc).

## Section 9.2.3.11 Energy Conservation Cycle (additional):

- When a machine is in the Automatic Cycle Blocked or Starved for a period of time the machine shall turn off some of its subsystems to conserve energy, and remain in the Automatic Mode, and display on the operator panel "Minimum Energy Conservation Automatic Mode". The time recommendation is 45 minutes. Other subsystems may remain running if required by the process (e.g. for quality reasons).
- When the machine is ready to run again (no longer blocked or starved in Minimum Energy Conservation Automatic Mode), the machine shall automatically re-start the subsystems (including sounding the start-up horn if available) and return to the Automatic Cycle Running mode it was previously in.

**GMPT Document****GF6 F269 Transmission Case  
Machining****Supplier Compliance  
Confirmation**  
(YES – Comply)  
(NO - Deviation Request Required)

- If the machine remains in Minimum Energy Conservation Automatic Mode for an additional period of time, the machine shall turn off all of its subsystems to conserve the maximum amount of energy, and change out of Automatic Mode into No Mode, and display on the operator panel “Maximum Energy Conservation Mode – Manual Restart Required”. The time recommendation is 2 hours. Another recommendation is the same time it would take to re-warm-up and prepare the machine for production.
- When the machine is ready to run again (no longer blocked or starved in Maximum Energy Conservation Mode), the machine must be restarted manually by an operator.

Section 17.2.2, 17.2.4, 17.2.5 Control Drawing Requirements (clarification):

- All controls drawings for new and re-tooled equipment must be provided in AutoCAD® with ANSI / NFPA Device Identifiers. (Does not apply to Assembly)
- Drawings shall be printed in a legible format on A3 or 11” x 17” paper. (Does not apply to Assembly)

SP-E-DPM version G1.0 Direct Part Marking & Validation Addendum:

Section 6.3 2D Marking Data Format

- The following replaces what is currently in the version G1.0 of the specification. Refer to the supporting documentation during S.E.

This is specific to the GF6 Program and is not the new Global format



GMPT Document

### GF6 F269 Transmission Case Machining

**Supplier Compliance Confirmation**  
(YES - Comply)  
(NO - Deviation Request Required)

#### PUN (part unique number) IDENTIFICATION FORMAT

Total of 14 Characters For PUN, With Optional Station Bypass Character.															
	1	2	3	4	5	6	7	8	9	10	11	12	13	14	
Identifier Description	Part / Model ID		Part Type		Time Of Build				Part Sequence Number						
	Model Year	Designation	Model	Plant Code	Build Year	Code (mnd)	Julian Date Code	Julian Date Code	Julian Date Code	Shift Code	Machine Identifier	Cat or Number	Sequence of Number	Sequence of Serial	Sequence of Number
Valid Range	Alpha Uppercase A - Z or Numeric	Alpha Uppercase A - Z	Alpha Uppercase A - Z	Alpha Uppercase A - Z or Numeric	Alpha Uppercase A - Z or Numeric	Numeric Only; 0 - 9	Numeric Only; 0 - 9	Numeric Only; 0 - 9	Numeric Only; 0 - 9	Alpha Uppercase A - Z or Numeric	Alpha Uppercase A - Z	Numeric Only; 0 - 9	Numeric Only; 0 - 9	Numeric Only; 0 - 9	Numeric Only; 0 - 9
Usage	Required	Required	Required	Required	Required	Required	Required	Required	Required	Required	Required	Required	Required	Required	Required
Data Format Sample	8	A	H	7	8	3	6	5	1	A	9	9	9	9	
EXAMPLE	9	B	E	Y	9	2	7	8	1	N	0	0	0	1	

[0001 - 9999 possible Sequence/Serial Numbers]  
Note: Counter resets at start of each shift.

A =  
B =  
C =  
N = N/A

1 = Shift 1  
2 = Shift 2  
3 = Shift 3

[0 - 365 days]

Actual calendar year of build.

R = GMDAT  
M = SGM  
P = SLP  
Y = TTO  
? = STC = St. Cat

- A = Hub asm 1-2-3-4 CLU (Purchase part)
- B = Hub asm 2-6 & 3-5/REV CLU (Purchase part)
- C = Case (Machining)
- D = Housing asm 1-2-3-4 & 3-5 REV CLU (Purchase part)
- E = Input Carrier (Assembly)
- F = Output Carrier (Assembly)
- G = Output Unit (Assembly)
- H = Housing asm 4-5-6 CLU (Purchase part)
- J = 1234 Clutch (Assembly)
- K = 456 Clutch (Assembly)
- L = Lower Valve Body (Machining)
- M = Hub asm 4-5-6 CLU (Purchase part)
- N =
- P = Pump Cover (Assembly)
- Q = Pump cover (Machining)
- R = Reaction Carrier
- S = Center Support (Assembly)
- T = TCv Housing (Assembly)
- U = Upper Valve Body (Machining)
- V = Valve Body (Assembly)
- W = Support & Shaft (Machining)
- X = TCv Housing (Machining)
- Y =

See detail sheets

6 = 2006 (Start of Production represents 2006 MY)  
7 = 2007  
8 = 2008  
9 = 2009  
0 = 2010

**Human Readable:**  
6T40-365-1-0001 ==Model-Date-Shift-Sequence



GMPT Document

GF6 F269 Transmission Case  
MachiningSupplier Compliance  
Confirmation  
(YES – Comply)  
(NO - Deviation Request Required)**PUN (Part Unique Number) For Part Marking only.**

SP-E-Agile CNC Programming specification, version G2.1 (additional):

Five (5) High Level Recommendations to OEM's to Enable Compensation Program for CNC's

1. Global offset work coordinate system to allow use of compensation program called 'COMP'. COMP is a new program, internally written and maintained. COMP was formally known as PCOS.
2. Structured CNC programming format per specifications.
3. HMI screen for inputting offset values.
4. NC A/B table adjustable, resolution 0.001 degree.
5. Full range of macro variables
  - Common macro variable #100~#199, #500~#999 for Fanuc
  - Defining any variable for Siemens

'COMP' Program for CNC targeting - Calculates the CNC machine program offset values to ensure quality part. Uses CMM data as an input. Benefits: reduce time for MRO, PPAP, and maintain part quality during normal production.

**ASSEMBLY CONTROLS REQUIRMENTS - Addendum**

The equipment supplier shall use all GM electrical and fluid power specifications, application notes and project books when bidding these projects. Any variation from these documents shall be accompanied by an approved deviation. If no deviation exists with variations while bidding and the supplier is awarded the program, the supplier shall remain responsible to comply with all GM specifications, application notes, and project books.

**7.10.1 Transmission Line and Sub-Assemblies**

- The primary controls supplier selected for the transmission assembly line, shall be the same supplier for all sub-systems. Even when the subassembly and transmission assembly equipment suppliers differ.

If the equipment supplier selects Rockwell as the primary controls supplier, then, the equipment supplier shall purchase the controls hardware from Rockwell including boxes for MWS kit, safety I/O kit, AWS kit, Conveyor Kit, Drive panel kit. Refer to table below

- *1000-L35E-DPM MANUAL WORK STATION BOX, INCLUDES RFID CONTROLLER AND 1 TRNSCIEVER*
- *1000-L43-AWS AUTO WORK STATION CONTROL, INCLUDES PANEL VIEW PLUS 1000CE, RFID CONTROLLER & 1 TRNSCIEVER*
- *1000-CC5-ETHERNET CONVEYOR DRIVE INTERFACE PANEL*
- *1000-CC-ESTOP CONVEYOR REMOTE E-STOP*
- *1000-CC-DRIVE CONVEYOR MOTOR DRIVE*

The equipment supplier shall use the global project books version G2.0 for Hirschmann and Cognex.

The equipment supplier shall use version 2.0 of CL-E-Technifor.

In addition to Siemens and Rockwell project books, the equipment supplier shall also use addendums to both project books. The equipment supplier shall also provide in writing its compliance to section 8.2 clarifications.

**GMPT Document****GF6 F269 Transmission Case  
Machining****Supplier Compliance  
Confirmation**  
(YES – Comply)  
(NO - Deviation Request Required)

Drawings will be IEC symbols with ANSI identifiers and ANSI layout size A2

Use of Ferrules - The equipment supplier shall reference section 13.1.1 of GM spec SP-E-60204 version G2.0

**7.10.2 Forecasting of Primary Controls Supplier Long Lead Components**

- The equipment supplier shall submit to the lead GM lead engineer a forecast of the required primary controls supplier equipment after SE. This forecast shall also be delivered to the equipment supplier's component suppliers.

**7.10.3 Sub Contracted Hardware and Software Controls Design**

- All sub-contracted controls design sources shall be approved by the lead GM Lead engineer
- All sub-contracted controls design sources shall attend a FACS workshop and a hands-on FACS training course.
- If a sub-contracted controls design source is not approved, GM will provide a list of approved sub-contractors.
- Equipment suppliers must provide the list of sub contractors at time of bid.

**7.10.4 Robot Simulation**

- The equipment supplier shall provide a milestone timing chart with critical mechanical design gates in which robot simulation can be properly accomplished. This document shall be provided with the equipment supplier bid.

**7.10.5 Retool of Equipment**

- All retooled equipment must be updated to the latest controls specifications, application notes, and project books.

**7.10.6 Training & Support**

- The equipment supplier design and install teams shall have FACS hands-on training provided by the chosen primary controls supplier and funded by the equipment supplier. As mentioned above, this shall include all subcontracted resources.
- The equipment supplier shall purchase two months of FACS Subject Matter Expert support from a GM approved supplier for the end user plant.
- The equipment supplier shall purchase one month of FACS Subject Matter Expert support from a GM approved supplier for equipment supplier onsite support of development/debug.

**7.10.7 FACS & NMS**

- ALL FACS related issues shall be logged in <http://eliteengineering.fogbugz.com>
- The FACS Server shall be DELL. Type of enclosure shall be telephone booth style with access from front and back of cabinet
- The Network Management PC shall be the same as the Dell FACS Server. Network Management software shall be provided per GM approved supplier.
- The equipment supplier selected for the transmission assembly line shall be responsible for the purchase of the FACS server and complete merger of the FACS system database for the entire assembly system to include all subassemblies. i.e. Head Sub, etc. The merger of the FACS database shall be purchased from a GM approved supplier.
- The Equipment supplier shall provide a "Processor" user license for Microsoft SQL Server on the following Computers :FACS server and Vision Server.



GMPT Document

GF6 F269 Transmission Case  
Machining**Supplier Compliance  
Confirmation**  
(YES – Comply)  
(NO - Deviation Request Required)**7.10.8 Pneumatic**

- The conveyor line shall have one air drop and header for all MWS's and CC motions. The header shall exhaust upon an e-stop from a MWS or conveyor controller e-stop. Each MWS station shall have a separate lockable relieving ball valve.
- Semi Auto Station light curtain functions:
  - The station shall not exhaust the air when it is ok to enter the station a green shall indicate ok to enter.
  - The entry light shall indicate RED when it is Not OK to enter. If it is not OK to enter, the station will exhaust the air and go into e-stop if the light curtain is interrupted. Upon reset of station, the station shall not automatically reset.

**7.10.9 Electrical**

- The thermal calculation for the electrical cabinets shall be done with an internal panel maximum temperature of 40 degrees Celsius.
- Installation of wire tags shall use hard label tags for all cables.. These tags shall not be secured with tie wraps on communication cables.
- All spare wires are to be wired to spare terminals
- Wire Ferules must be used when terminating to terminals
- Conveyor Panels Height shall not exceed 1.5m
- The equipment supplier shall provide HMIs and PCs with a swinging' arm for all Semi -automatic and automatic stations where a conveyor requiring steps enters and exits the station.
- Wiring Service loop for MWS push button BOX. The equipment supplier shall provide a 2M service loop of cable for MWS push button box and shall provide service loop to field devices to ensure proper installation at plant.
- RF tags shall be cleared at the beginning of the assembly line with the exception of the RFID header.
- Gate or light curtain access on the operations side of the line shall have a secondary electrical disconnect labeled E3 and secondary air disconnect labeled A2. These disconnects shall be in series with the main electrical and air supplies.
- Hand scanner or hand scanner base shall use serial communication.
- GM standardized hand scanner boxes shall be utilized.
- Where an operator is performing an interlocked task, the equipment supplier shall use the a GMGM approved Green task indicator light which shall indicate task complete.
- Each MWS shall have a minimum of 4 task indicator lights with additional holes and room for 4 more indicators. Replaceable tags shall be positioned near the task indicator lights and shall be easily read by the operator. These task indicator plates shall be purchased from an approved GM Supplier.
- The equipment supplier shall use a GMGM approved indicator light for when it is OK to enter a Semi Auto station. GREEN for OK to Enter, and RED for NOK to enter
- SCCR, FLA and heat calculation ratings shall be provided with drawing submissions
- Electrical disconnect shall be Bussman rod style
- A Keyboard holder shall be provided for all PCs
- The equipment supplier shall use the DUPLICON IP 67 pluggable solution for power distribution for motor conveyance, The Duplicon connectors shall be keyed for 480V with black handles. The 480V cable shall have a black jacket.
- MWS power shall utilize a Duplicon IP 67 pluggable solution bus with mini style three pin connectors installed in the Duplicon housings. The Duplicon connector shall be keyed for 120/ 240V with Red handles. The cable shall have a red jacket.
- All conveyance I/O control power shall be distributed with Duplicon IP 67 pluggable solution and IP67 Power Supply "Similar to MWS"
- All Duplicon buses shall have a contactor which shall remove power from the bus with any plug removed.
- ET200Pro CPU shall have 1MB micro memory card

**GMPT Document****GF6 F269 Transmission Case  
Machining****Supplier Compliance  
Confirmation**  
(YES – Comply)  
(NO - Deviation Request Required)

- Unicast shall be used for Ethernet IP / Profinet
- A Master Electrical Drawing Set shall be used and approved by the lead controls engineer.
- The Equipment supplier shall be permitted to quote Amphenol for 120VAC and 480VAC conveyor power distribution. For sub systems, both power distribution options shall be quoted (Phoenix and Amphenol). The equipment supplier shall use overmolded cabling for the Amphenol solution.

Contact: Terri Miller

Amphenol Sine and Tichel Automotive Products

N A Sales Manager

586 876 6796

**7.10.10 Safety**

- Safety areas shall be defined in a G-Risk assessment "Note: These areas Shall not be represented as ZONES"
- Ratchet bar, Rod lock and Shot Pins must be used in Semi Auto stations. Rod locks can only be used in Auto stations to stop process motion, and not to be used for safety of people. The equipment supplier shall use the safety specs in regards to stroke length and weight for when a ratchet bar, rodlock or shot pin is required.
- Profinet Safe Or Ethernet IP Safe shall be used for all IP65/7 VFDs/Contactors for conveyance control.
- Profinet Safe or Ethernet IP safe I/O shall be used for all safety components such as estops, pull cords, etc.
- Rope pulls shall have M12 connectors which shall plug into IP67 safe I/O. Additionally, the rope pull shall have a separate red indicator located near the rope pull to indicate "pulled" or stopped condition. This indicator shall plug directly into IP67 I/O.
- Profinet or Ethernet IP shall be used for all non-safe I/O for conveyance control
- All estop devices on the conveyor system shall connect directly to the primary controls supplier safety I/O. The devices shall utilize an M12 connector and single cable to connect to I/O. Rope pull devices shall have an additional M12 IP65/7 light in close proximity of the switch which shall indicate that the rope pull has been "pulled". This shall be powered from standard outputs on field I/O.
- Reference below examples.

GMPT Document

### GF6 F269 Transmission Case Machining

**Supplier Compliance Confirmation**  
(YES – Comply)  
(NO - Deviation Request Required)

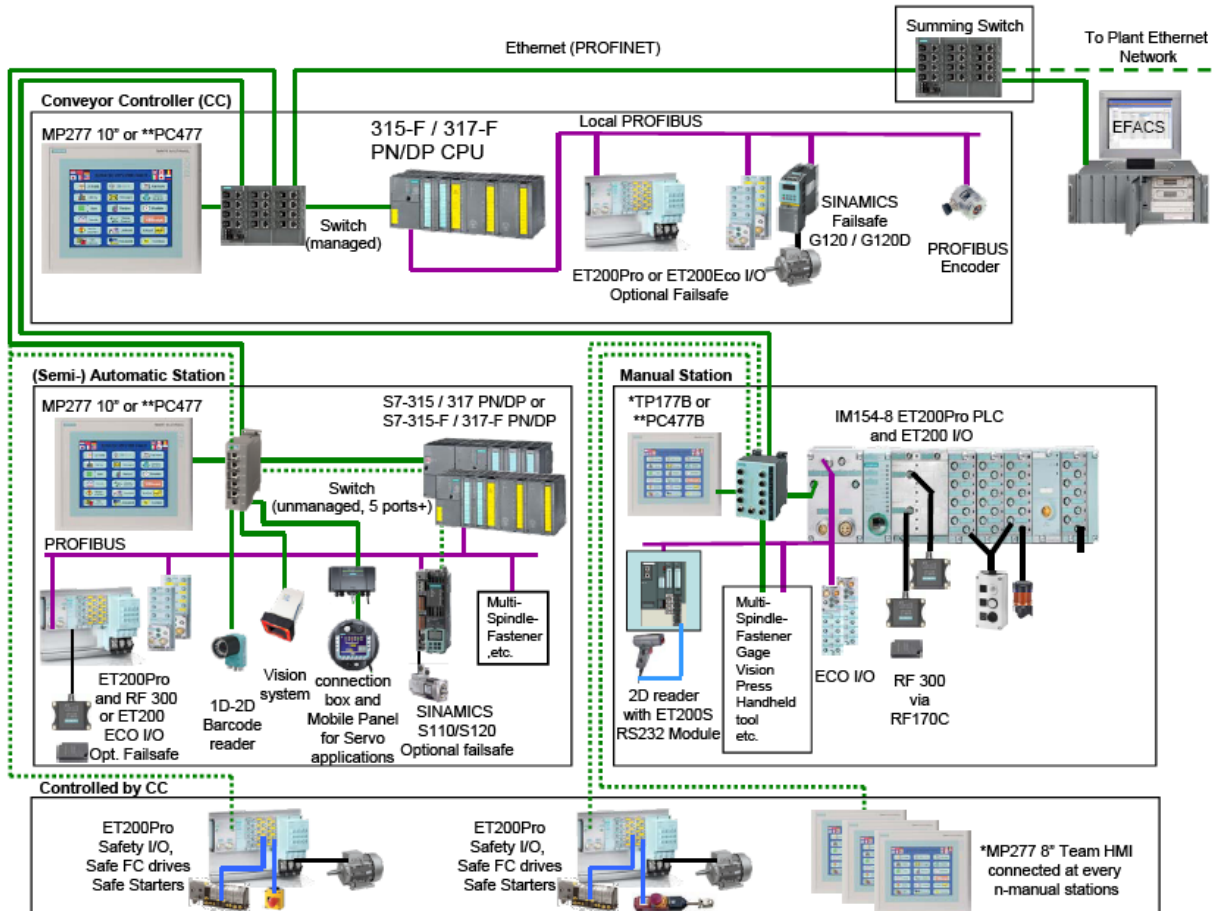

\* Push buttons and pilot lights or pull cords or HMI are project dependent \*\* PC477B if PC is required e.g. for Vision-systems, Nut-runner, Repair stations,...

Figure 1 - Profinet Safe Example

<p><b>GMPT Document</b></p>	<p><b>GF6 F269 Transmission Case Machining</b></p>	<p><b>Supplier Compliance Confirmation</b> (YES – Comply) (NO - Deviation Request Required)</p>
-----------------------------	--	---

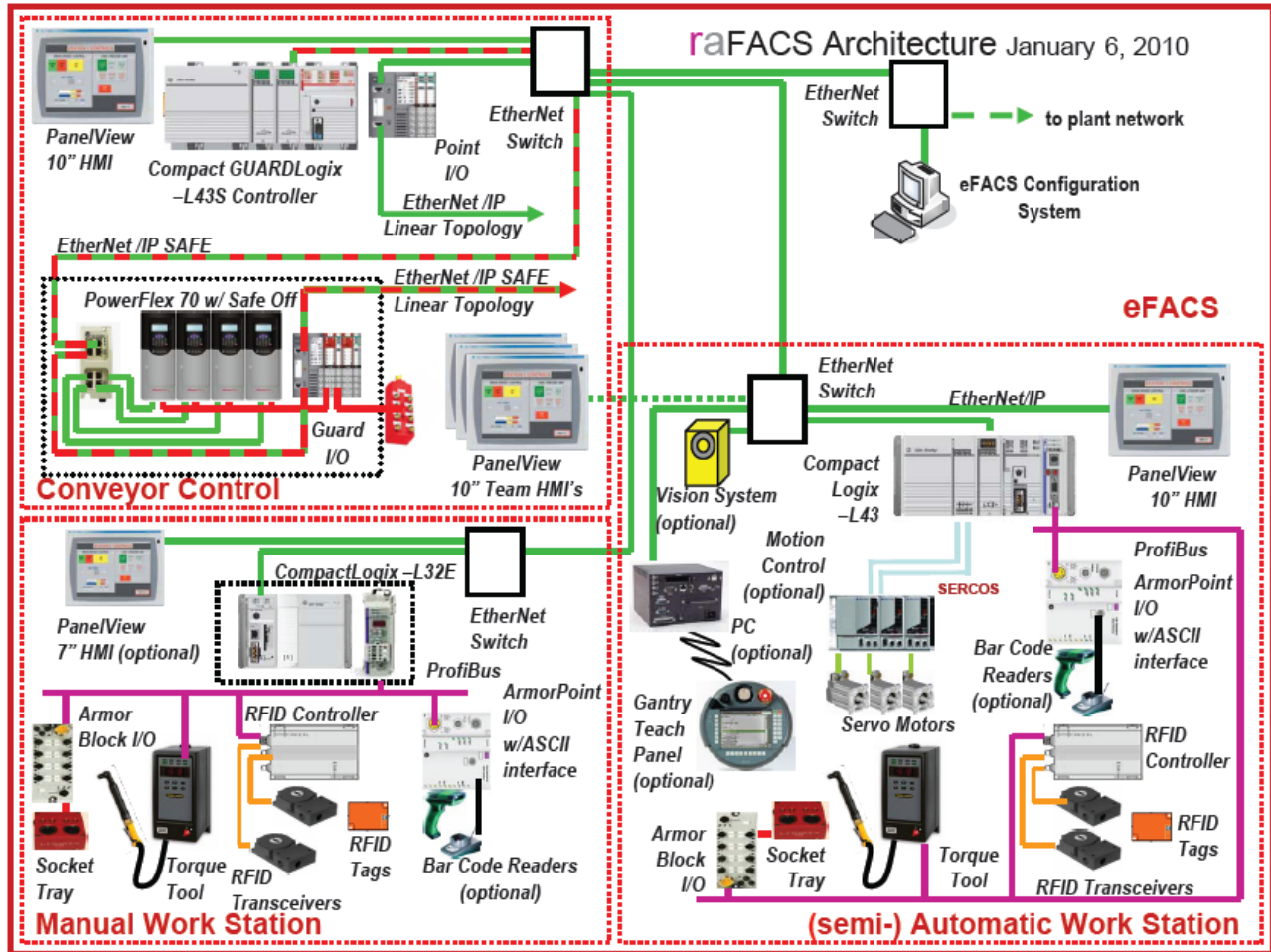

Figure 2 - Ethernet/IP Example

- Dog houses/Entrance/Exit on automatic stations with pedestal style conveyance shall have light curtain and muting switches to protect exposure where hazards exist.
- Quick access lockable switches shall be provided at each entry door to control all hazards. The functionalities of these switches shall be determined during the risk assessments
- The equipment supplier shall comply with GM safety controls system requirements. See the attachment, slide 30 and beyond, for reference.



GMPT\_Safety  
Control Systems FES

**7.10.11 Error Proofing Vision Systems**

- Smart cameras or vision sensors shall be used when practical.
- Cameras shall have Ethernet M12 connectors.
- Image Storage System shall have:
  - Vision verification software installed and functional per camera on the image storage system

**GMPT Document**

**GF6 F269 Transmission Case Machining**

**Supplier Compliance Confirmation**  
 (YES – Comply)  
 (NO - Deviation Request Required)

- Image storage for up to one year of images for OK/NOK parts in JPG format with the meta data ie. Process data for each camera.
- 5000 images in BMP format for each camera
- All stored images shall be FIFO.
- GM approved rack mount DELL computer(s) shall be mounted in the FACS enclosure if possible.
- The computer shall be capable of allowing access to historical images, locally and able to browse remotely "Eg. Internet explore", based on PUN, station, date and time range, etc.
- Distributed Camera system:
  - Distributed camera system shall require approval of GM lead controls engineer.
  - Cameras shall not be distributed for more than one station.
  - Cameras and PC shall connect to a unmanaged switch on IECN network at the station
- Station HMI and vision systems:
  - OEM shall purchase the vision suppliers CE display software to be installed on the station machine HMI
  - The station HMI shall provide navigation between cameras and display current image of the designated camera.
  - The station HMI shall be capable of retrieving historical images from the image storage system

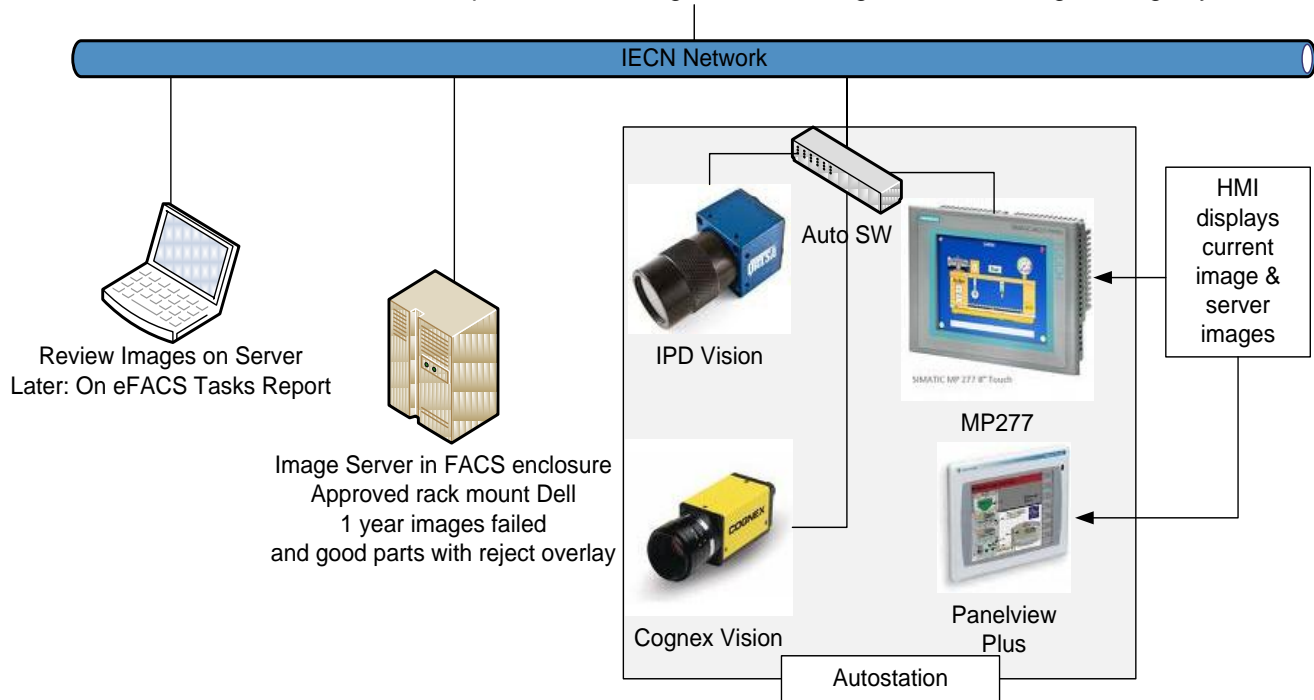

**7.10.12 IT Systems**

- Any QDAS PC shall have two (2) Ethernet cards i.e. USON, Promess, fastening, and will connect to the station switch etc.
- The equipment supplier shall be responsible for the purchase and installation of the current GM approved Virus Scan Software, Acronis Software, and solidcore software. The equipment supplier shall follow procedures provided by GM.
- The equipment supplier shall be responsible for implementing GM memory map and interfacing with PAS, PM&C, FLEXNET and UD&C.
- Every Flexnet transaction point shall have a blue light located at operator level to inform the operator of NOK Flexnet part and communication lost.



GMPT Document

GF6 F269 Transmission Case  
MachiningSupplier Compliance  
Confirmation  
(YES – Comply)  
(NO - Deviation Request Required)

- PC operating systems shall be embedded where possible.

**7.10.13 Fastening Network**

- All fastening devices in a station shall be connected to a the station Ethernet switch

**7.10.14 HMI**

- RGUs shall be a minimum 8” screen size.
- The equipment supplier is responsible for providing RGUs (Remote Graphical Unit) for the conveyance where line of sight control issues exist.
- The equipment supplier shall develop standard Team HMI screens. Template screens may be available from the primary controls supplier.

**7.10.15 MWS and Conveyor Controller Node Plate Requirements**

- All Manual Workstations shall require an aluminum plate where the PLC, Power Supply, IP67 Switch, etc are mounted
- The MWS plate shall lift holes on each side of the plate and labeled lift holes. In addition, metal handles shall be mounted to the top of the plate.
- The plate shall be bolted to the conveyor via T-Slot bolts. If additional support is required at the front of the mounting plate, feet shall be added for stability and shall not require lagging to the floor.
- Motor, VFD, I/O, and valving nodes shall also be mounted to an aluminum plate and mounted to the conveyor similar in configuration to the MWS.
- Task Indicator lights shall be mounted to the top of the MWS Plate and face towards the operator. All other components shall face the maintenance side of the line. Task indicator lights shall be mounted horizontally. Task indicator lights shall be configured where completion of tasks move with the flow of the conveyor. Task indicator lights shall be mounted at a height where the operator can easily see the lights during processing of the part.
- Plate cabling shall be secured yet allow for easy addition of MWS devices and tools.
- Quote must include a sketch of manual work station plate layout.

**7.10.16 Flash Drive PC**

Flash drive PC shall have a minimum of 16 G

**7.11 FLUID POWER CONTROL SPECIFICATION**

Hydraulic Systems Specification	SP-F-Hydraulic	2010-01-08	G2.0	_____
Lubrication Systems Specification	SP-F-Lubrication	2010-01-08	G2.0	_____
Pneumatic Systems Specification	SP-F-Pneumatic	2010-01-08	G2.0	_____
Maintenance Lubricant Standard LS2 For Industrial Equipment and Machine Tools (North America)	GM 1721 – LS2	Latest	Latest	_____

SP-F-Hydraulic Specification Addendum:

Section 10.5.6 Energy Conservation Cycle (additional):

**GMPT Document****GF6 F269 Transmission Case  
Machining****Supplier Compliance  
Confirmation**  
(YES – Comply)  
(NO - Deviation Request Required)

- As part of the Energy Conservation Cycle requirement in SP-E-60204, the hydraulic system shall be included in the subsystems to be turned off if not required by the process (e.g. for quality reasons).

SP-F-Pneumatic Specification Addendum:

Section 4.3.1 Safety Requirements - Design Consideration (additional):

- The safety lockout shall be before the drip leg in both rebuild/retool and new build applications.

Section 8.1.3.1 Pressure Drops (additional):

- The air preparation module air filter shall have a separate electronic pressure switch with 2 operating points to monitor for a dirty filter causing a drop in system pressure.
  - 1st Switch Point: Filter 75% Clogged Warning
  - 2nd Switch Point: Filter 100% Clogged Machine End of Cycle Stop

Section 10.5.6 Energy Conservation Cycle (additional):

- As part of the Energy Conservation Cycle requirement in SP-E-60204, the pneumatic system shall be included in the subsystems to be turned off if not required by the process (e.g. for quality reasons).

Section 10.5.7 Air Blow Offs (additional):

- To reduce air consumption air blow offs shall be regulated to the required pressure for the process and not at plant pressure. Blow offs shall be controlled to be used only when required eliminating the need for a constant pressure leak.

Section 11.3 Air Consumption Monitoring (additional):

- The machine builder will measure the air consumption in SCFM (Standard Cubic Feet per Minute) of the machine using a flow meter. This ideal air consumption measurement will be used as the air consumption baseline for the machine and shall be inputted in to the data utility sheet. This ideal air consumption measurement can later be used to improve the air consumption of the machine or be compared to the actual air consumption of the machine in the plant to determine air leakage.

**7.12 PROCESS MECHANICAL EQUIPMENT SPECIFICATION**

<b>Mechanical Specifications</b>	<b>SP-M-Mechanical</b>	<b>2010-01-08</b>	<b>G2.0</b>	_____
<b>Fastening Systems Specification</b>	<b>SP-M-Fastening-Systems</b>	<b>2010-01-08</b>	<b>G2.0</b>	_____
<b>Leak Test Station Requirements</b>	<b>SP-M-Leak Test Reqt - Engines</b>	<b>2010-01-08</b>	<b>G2.0</b>	_____
<b>Cylinder Head and Engine Assembly Torque to Turn Requirements</b>	<b>SP-M-Torque To Turn</b>	<b>2010-01-08</b>	<b>G2.0</b>	_____
<b>Lift Assist Design, Build &amp; Runoff Specification</b>	<b>SP-M-Lift Assists</b>	<b>2010-01-08</b>	<b>G2.0</b>	_____
<b>Overhead Bridge, Rail and Suspension Specification</b>	<b>SP-M-Bridge &amp; Rail Systems</b>	<b>2010-01-08</b>	<b>G2.0</b>	_____



<b>GMPT Document</b>	<b>GF6 F269 Transmission Case Machining</b>	<b>Supplier Compliance Confirmation</b> (YES – Comply) (NO - Deviation Request Required)		
----------------------	---	--	--	--

Engine Cold Test System Requirements	SP-M-Cold Test System Reqts	2010-01-08	G2.0	_____
Roller Conveyor Systems Operational Requirements	SP-M-Roller Conveyor Systems	2010-01-08	G2.0	_____

### 7.13 TOOLING SPECIFICATION

Cutting Tool Specification	SP-T- Cutting Tool	2010-01-08	G2.0	_____
----------------------------	--------------------	------------	------	-------

### 7.14 PLANT ENGINEERING PROCESS SUPPORT EQUIPMENT SPECIFICATION

Regional Coolant Filtration Systems	SP-P-Regional Cool. Filter	2010-01-08	G2.0	_____
Single Machine Coolant Filtration Systems	SP-P-Single Mach. Cool. Filter	2010-01-08	G2.0	_____
Coolant Pump over Systems for Machine Tools	SP-P-Mach. Cool. Pump	2010-01-08	G2.0	_____
Chip & Coolant Management for Machine Tools	SP-P-Mach. Cool. Mgmt.	2010-01-08	G2.0	_____
Machinery & Equipment Painting and Piping Identification Standards	SP-P-Equip. Paint	2010-01-08	G2.0	_____
Machinery & Equipment Mounting Standards	SP-P-Equip. Mount	2010-01-08	G2.0	_____
Mist Collection Systems	SP-P-Mist Collect	2010-01-08	G2.0	_____
Machine Tool & Assembly Support Systems	SP-P-Mach. & Assy. Support	2010-01-08	G2.0	_____
Utility Piping Paint & Identification	SP-P-Utility Piping Paint & Identification	2010-01-08	G2.0	_____
Process Fluid Components Requirements	SP-P-Process Fluid Component Requirements	2010-01-08	G2.0	_____

### 7.15 GLOBAL MANUFACTURING SYSTEM AND QUALITY ANDON REQUIREMENTS

Quality Andon System Specification	SP-I-QAS	2010-01-08	G2.0	_____
------------------------------------	----------	------------	------	-------

Global Manufacturing System (GMS) Guiding Principles Addendum (additional):

#### 7.15.1 Andon:

- Review Andon requirements and develop concept design specific to the equipment, including ancillary equipment that is supported by manufacturing departments (CMM's, filters, etc).



## GMPT Document

GF6 F269 Transmission Case  
MachiningSupplier Compliance  
Confirmation  
(YES – Comply)  
(NO - Deviation Request Required)

- Review Andon System interface requirements (push buttons and/or pull cords), pace light requirements, as well as interlock requirements. (Reference SP-E Machining Systems and SP-E Assembly Controls for stack pole light information. SP-E Assembly Controls also provides pace light, pull cord and push button examples).
- For Cellular Machining departments, where machinery is manually loaded in a cyclic (i.e. repetitive to takt time) manner, an Andon call-for-help must be provided that is activated by either a single cord pull or single button push within the operator's walk path.
  - Pull cord or push-button must be accessible at intervals of a half takt or less within the operator's walk path.
  - The Andon is re-set by pulling or pushing one additional time. No acknowledge required by Team Leader.
- Additionally, manned stations such as quality stations (CARE, verification stations, etc.) kitting areas, repair areas, etc. require the ability to activate an Andon call-for-help activated by either a single cord pull or single button push.
- Review memory map requirements (Refer to *AN-E Memory Map*) for inputs that are necessary for interfacing with PT-PM&C (Production Monitoring and Control). (Refer to *SP-I-QAS* for typical Andon board configurations.)
- Assembly Dept's: Stacklights exists at all manual stations, including visual inspection (inc. CARE) & quality verification stations, kitting areas, auto. and semi-auto. stations. Implication on qty of PLC's required.
- Machining Dept's: stacklights exists at all auto/semi-auto machines, including CMM's, visual and quality verification stations. One stackpole light provided per machine. Stacklights are used as appropriate to identify specific machine status.
  - Need to consider where the operator's are located and their geographic area of work. Can they see the stacklights? May need additional wire and mounting bracket to place in an appropriate location.
- Types of information reflected on Andon Boards and/or stack lights include: Fault notification, impending and in-progress toolchanges/gage checks, machine running status (stacklights only), call-for-help, target vs. actual counts. When Team Member's (TM's) call-for-help, tooling & equipment are interlocked to Andon (where system allows) to stop product at the fixed position stop for conveyors (where process allows), or in station at the end of takt time for stop/start stations. Single pull cord/push button call-for-help capability provided. The Andon is reset by an additional push/pull.

**7.15.2 Material low/high:**

- Assembly Controls Spec shows a Yellow stacklight for hoppers when material is low (low limit switch). Note: this is not reflected on Andon Board – stacklight only.
- Machining Material to utilize Yellow stacklight on material hoppers as well. Again, this would be stacklight only – no Andon.
- Additional Material low/high Yellow stacklight at load or unload buffers or automation at input/output operations of the department. Andon Board will only reflect when the input operation is Starved or the Output operation is Blocked.

**7.15.3 Assembly:**

- Controls logic for diagnostic station Andon/PM&C interface for Team Leader (TL) interface (treated as an overcycle).



GMPT Document

**GF6 F269 Transmission Case  
Machining****Supplier Compliance  
Confirmation**  
(YES – Comply)  
(NO - Deviation Request Required)

- Reference Assembly's Guiding Principles for system design (see GMS New Program Support personnel to obtain)

**7.15.4 Gage spurs and reject spurs:**

- Gage spur and reject spur should be separate for Quality purposes.
- Should be located on the operator side of the equipment (BOE does not agree with this in some cases – need to discuss during S.E.)
- Should be sized appropriately (i.e. if running parallel operations, may need chutes that accommodate one part from each) (BOE typically says 3 pzs zones).
- Gage checks, both control plan changes and after toolchange, hand-gage-check, surface-finish-check, manual-inspection-request, if they go to a gage chute, should trigger Andon Blue light.

**7.15.5 Controls:**

- New machinery – main HMI's operator panels shall have hard button to call for Team Leader (TL). To be discussed and finalized during S.E.
- CMM – needs newest memory map for Andon interface
- Utilize latest Memory map – includes new Station Andon Hold (assembly) requirement

**7.15.6 Line of Sight:**

- Layout of equipment should take into consideration line of sight. The Goals are to:
  - To make open communication easier
  - To make obvious who is available
  - To create a safe working environment
  - Ability for responders to see Andon Boards and Stack lights (shop floor)
  - Enablers to enhance Good Line of Sight may include:
    - Strategically placed equipment to enable line of sight (evaluate perpendicular vs. parallel placement, place taller equipment against existing walls, transformer placement consideration, etc.)
    - Minimize height of equipment where possible (5 foot/1.5 m)

**7.15.7 Gage Tables and visual inspection areas:**

- Task lighting shall be provided (plant lighting is not strong enough for good inspections to take place).
- Corporation standard [NAO 0066](#) calls for 100 FC for inspection tasks.

**7.15.8 ATT (Actual Takt Time):**

- May vary from loop to loop, department to department ( i.e. do not assume that if ATT for Assembly is 60 sec's, that this is the same # used for Loop 1 and Head Sub.) Need to look at % uptime of each loop/department.



GMPT Document

**GF6 F269 Transmission Case  
Machining****Supplier Compliance  
Confirmation**  
(YES – Comply)  
(NO - Deviation Request Required)**7.15.9 Independent Repair & Confirmation:**

- Repair confirmation (man and/or machine) is conducted independently of the repair function (preferably by Quality). If the plan is to reintroduce to the machine – what is the error proofing to ensure that it cannot be reintroduced downstream of this operation? (for instance, RFID)

**7.15.10 Built in Quality:**

- GQR-016 Process Capability
- To improve process capability for Key Product Characteristics, Product Quality Characteristics and Standard Product Characteristics by ensuring Powertrain Process Capability Requirements are met as defined in Chart – A, page 4.

**7.15.11 Maintenance:**

- Two skilled trades classifications is the goal – electrical and mechanical. More reliance on the Team Member (TM) to do routine Preventative Maintenance tasks. Need to add visual identifiers and easy access to enable Total Productive Maintenance (TPM).
- Equipment design shall allow for readily accessible visual inspection of operating parameters, with the inspection to be completed within a minute or less. The inspection to be conducted must provide information about the equipment's normal and/or abnormal operating status (For example, clustering of gages, identification of normal operating parameters, etc).
- Equipment design shall allow the correcting of abnormalities or fine tuning such as adding lubrication or adjusting air pressure without removing guarding, shutting off power yet complying with all the GM safety and ergonomic standards. (Per ME SP-G-Maintenance Spec. Ver G1.0).
- The supplier shall provide a preliminary copy of the PM Plan during the project design and build phase. The PM plan will identify the state of the equipment during the PM task (i.e. is the equipment down or can it continue to run?). If this information is attained early enough, it can be input into the simulation in order to understand effects on thru-put. A final version of the PM Plan shall be provided at equipment pre-acceptance runoff at the Supplier's facility.
- Also, design equipment, to utilize common components (especially when going into an existing Brownfield site).

**7.15.12 Coordinate Measurement Machine (CMM) Andon & Stackpole Light Functionality Clarifications**

The following methods of display supports the direction set in QAS VG1.0 in which Andon display content is simple and easy to interpret.

- The Andon board's cell must clearly be labeled as an Inspection Machine, to distinguish it from other types of machines. For example, the word CMM should be used if the machine is a CMM. A Red, Yellow, Blue tri-light will be utilized on the Andon Board for the CMM in order to stay consistent with the other operations on the board. However, the Yellow and Blue lights will not be utilized, except when there is a Team Leader Help Call ( Red, Yellow, Blue flashing).
- The system must provide information on current CMM status.
- The system must provide information on estimated time remaining during CMM test only if SOR defines the need for this. NOTE this information is NOT communicated to the Andon board. It would be communicated to a CMM vendor supplied marquee board.
- The system must provide the ability to call for assistance.
- The Stackpole lights will follow specific behaviors as outlined here:

<b>GMPT Document</b>	<b>GF6 F269 Transmission Case Machining</b>	<b>Supplier Compliance Confirmation</b> (YES – Comply) (NO - Deviation Request Required)
----------------------	---	--

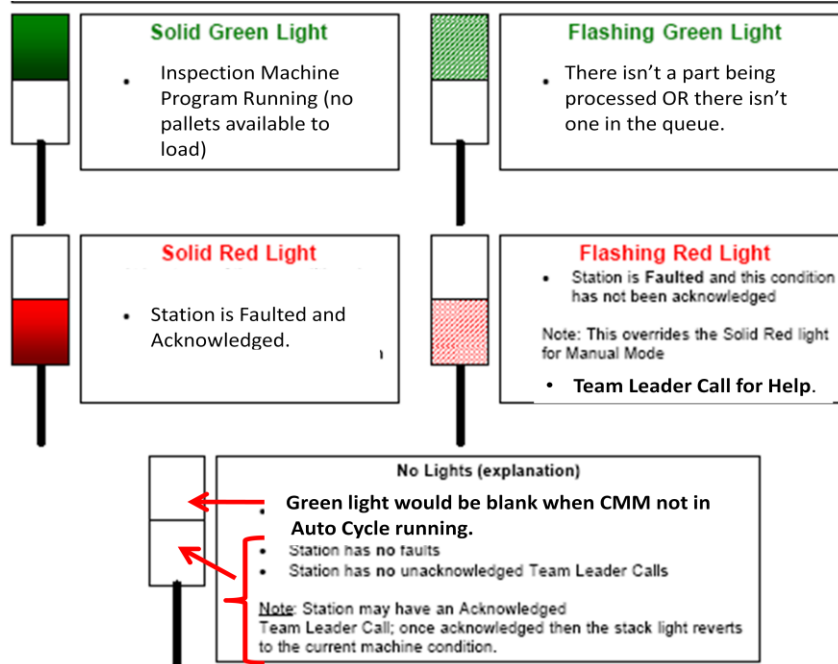

Light Color	Description	Light Off	Flashing	Solid
GREEN <sup>3</sup> (Stackpole only)	CMM Running	Inspection Machine Program Not Running	There is not a part being processed or there is a part in the queue	Inspection Machine Program Running
RED (Stackpole & Andon)	CMM Faulted or Assistance Call #n	No Faults <sup>1</sup> or No Assistance Call	Unacknowledged Fault <sup>1</sup> or Unacknowledged Assistance Call <sup>2</sup>	Acknowledged Fault <sup>1</sup>

<sup>1</sup> - A "Fault" is a condition that will prevent the machine from running, either immediately or at the end of the current program.  
<sup>2</sup> - Once the assistance call is acknowledged, the flashing of the lights will cease (they turn solid).  
<sup>3</sup> - From top to bottom, the order of lights on the stackpole follow the Machining standard: Green, Red.

<b>Call for Help</b>			
Light Condition	Description	Memory Map / Equation	Tunes / Comments
<b>Flash</b>	Call for Help	TEAM_HELP=ON and TEAM_HELP_ACK=OFF	Plays the "Call for Help" tune
<b>Off</b>	Call for Help (Acknowledged)	TEAM_HELP_ACK=ON	NOTE: Removed TEAM_HELP=ON from the equation.



<b>GMPT Document</b>	<b>GF6 F269 Transmission Case Machining</b>	<b>Supplier Compliance Confirmation</b> (YES – Comply) (NO - Deviation Request Required)
----------------------	---	--

<b>Off</b>	Call for Help (Complete)	TEAM_HELP=OFF	
------------	--------------------------	---------------	--

<b>Machine Faults</b>			
<u>Light Condition</u>	<u>Description</u>	<u>Memory Map / Equation</u>	<u>Tunes / Comments</u>
<b>Flash</b>	Machine Down due to a Fault (Un-Acknowledged)	FLT=ON and FLT_ACK=OFF	Plays the "Fault" tune
<b>Solid</b>	Machine Down due to a Fault (Acknowledged)	FLT=ON and FLT_ACK=ON (or NO_COMM)	Also show Red Solid when communication is lost (optional) NOTE: Red Solid will also show when there is a error in the PLC logic, e.g. (FLT=OFF and FLT_ACK=ON) should never occur.
<b>Off</b>	Machine is NOT Down due to a Fault	FLT=OFF	

- From the HMI's main menu, there must be a button labeled "Assistance Calls" (or "Trades Calls"). When pressed/clicked, this button must display the Trades Call screen/interface which allows the user to select which trade(s) to call from a list of up to eight trades.
- The names of each assistance call (eg. Team Leader, Electrical, Mechanical, etc.) are specified on a plant by plant basis and therefore must be updated to reflect what the requirements of the plant in which the machine will be installed. This list must be obtained by the CMM vendor and implemented prior to shipment of the machine, and the operator should not be allowed to change the names shown.
- Assistance Call #1 is reserved for the "Call For Help".
- Each assistance call will have two available buttons (1) Call/Cancel button, and (2) Acknowledge button. Each of the eight items on the screen may have one of three states: No-Call, Call-Active or Call-Acknowledged. For example, for Assistance Call#1, we begin in the No-Call state. Pushing the Ack PB has no effect, but pushing the Call/Cancel PB brings us into the Call-Active state, where the Call/Cancel PB will now be colored but the Ack PB will be flashing in color. Pressing the Call/Cancel PB would bring us back to the No-Call state, and back to the uncolored PB appearance, but pressing the Ack PB would take us instead to the Call-Acknowledged state, where the colored flashing of the Ack PB becomes solid. The colour and flashing indicates the state of the call. Again, from this last state, the Call/Cancel PB would return us to the No-Call state. There are other acceptable methods of display, but GMPT Engineers must approve a deviation from this document in such situations. All eight calls must function independently and consistently.
- An additional hard wired push button located on the push button panel is required for the "Call For Help" signal only.
- Pushing the hard wired push button once should create a "Call For Help". Pushing the button a second time should clear the "Call For Help". The hard wired button should trigger the same memory locations as indicated in the Basic Inspection Machine (CMM) Memory Map detailed above and in the Inspection Machine (CMM) Communication Protocol section of the Powertrain Memory Map document.

<b>GMPT Document</b>	<b>GF6 F269 Transmission Case Machining</b>	<b>Supplier Compliance Confirmation</b> (YES – Comply) (NO - Deviation Request Required)
----------------------	---	--

- For communication to a PLC/OPC-based Inspection Machine, PLC/OPC based solutions all power and network communications (NIC, drops, etc) are a requirement. PLCs used for this solution are to be authorized by GM Powertrain. The vendor is to supply a recommended communication enabler.
- For OPC interoperability the PC hosting the OPC Server may need to be added to the local plant domain.
- The I.T. System can connect to the CMM with standard drivers/tools as it would connect to any other Machining PLC.
- General procedure, in real-time, based on memory map information, send appropriate signals to display on ANDON cell(s). The method of display is specified in the Display Methodology section, above.
- To interpret the meaning of the individual information, please refer to the section entitled Inspection Machine Communication Protocol. The ANDON board itself must, of course, still be driven by the rules specified in the Display Methodology section.

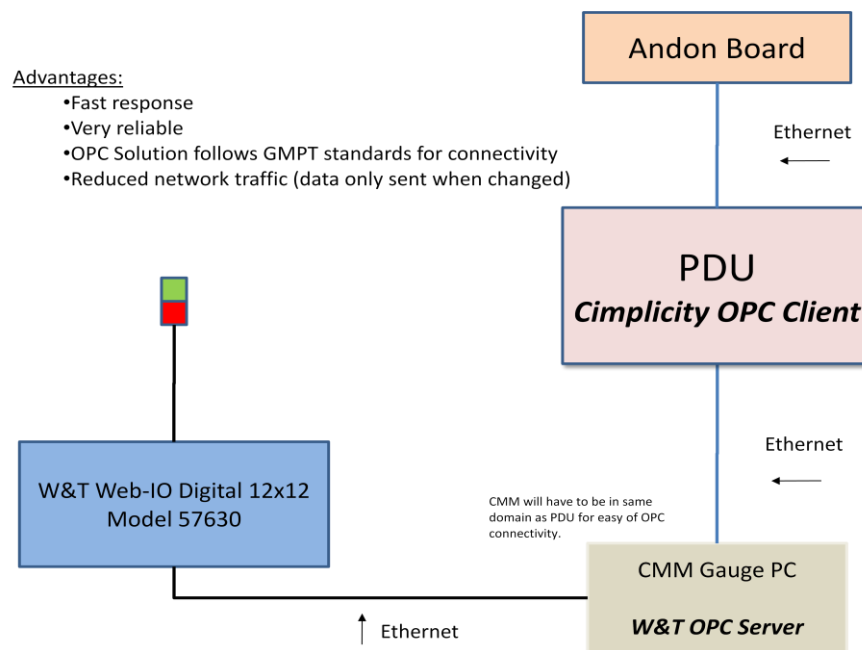

**7.16 FIRE PROTECTION REQUIREMENTS**

N/A

**7.17 LASER REQUIREMENTS**

All lasers, and laser systems, supplied to GM shall be rated and classified to meet international standards and fulfill the requirements of GM Global Design for Health and Safety Standard (GDHS2 - Section Laser and Laser System Applications).



GMPT Document

GF6 F269 Transmission Case  
Machining**Supplier Compliance  
Confirmation**  
(YES – Comply)  
(NO - Deviation Request Required)

The Supplier shall include within the equipment description of each quotation package their proposed use of all laser systems and the associated classification ratings (ANSI Z136.1, or IEC 60825, or CDRH) of the laser(s). The Supplier shall submit the classification ratings for both the laser as a system including the supplied enclosure, and for each embedded laser within the system.

GM CETC Laser Safety Officer shall be notified BEFORE purchase of the use of embedded lasers Class 3B or Class 4.

If the equipment supplier utilizes laser equipment for direct part marking, then the following shall apply.

All class 3b and 4 lasers and laser system shall be totally enclosed in a Class 1 Enclosure, as required in section 4.4 of GDHS 2.0,

All laser products shall comply with all applicable Federal and local laws, including but not limited to FDA, CDRH reporting requirements found in Title 21 CFR 1002.

MPE and NHZ calculations or other evidence supporting class 1 enclosure shall be submitted for GM LSO approval, as required in section 4.4 of GDHS 2.0

Walk in enclosures are not allowed for Direct Part Marking. (*ignore references found in GDHS2.0*)

All Access doors and lasers shutters shall be interlocked with control reliable wiring, as required in section 4.4 of GDHS 2.0 and ANSI Z136.1 section x

All MPE and NHZ calculations or Laser Safety assessments must be performed by “qualified” individuals, as outlined in ANSI Z 136.1 or IEC 60825. Credentials of “qualified” individuals should be submitted to GM for review. “Only personnel trained in laser safety, optical engineering, physics, or a related field, are suited to perform the detailed hazard evaluation computations or the classification determinations of a laser or laser system.” *ANSI Z-136.1 Section 3.1*

## 8.0 EQUIPMENT COMPONENTS AND SUBSYSTEMS

GMPT reserves the right to make final determination of the equipment components, and sub-systems, to be used on the project based on the Supplier preferences listed in their quotation responses, the GMPT destination site, and other project criteria.

### 8.1 SUPPLIER PREFERRED COMPONENTS AND SUB-SYSTEMS

For purchased components and sub-systems not listed in section 8.2 below the Supplier shall indicate their preferred choice for manufacturers and models of components and sub-systems to be used in equipment build in their quotation response package.

- If outside engineering is to be used in the development of the AP & fixture designs this must clearly be stated in the quotation and the source or sources specifically identified.



GMPT Document

GF6 F269 Transmission Case  
MachiningSupplier Compliance  
Confirmation  
(YES – Comply)  
(NO - Deviation Request Required)**8.2 GMPT APPROVED COMPONENTS AND SUB-SYSTEMS**

The Supplier shall include their preferred choices selected from the GMPT Project Books, and GMPT Approved Components and Suppliers listed below in their quotation response.

The Supplier shall only make substitutions from the GMPT Approved Component Lists upon receipt of an approved Deviation Request in accordance with GMPT change management procedures.

**8.2.1 ELECTRICAL COMPONENT LISTS AND PROJECT BOOKS**

Program Book / Guidelines for the use of Fanuc CNC Products	CL-E-Fanuc-CNC	2009-11-20	G1.0	_____
New & Major Program Book / Guidelines for FANUC Robots	CL-E-Fanuc-Robot	2009-04-08	V 4.0	_____
Program Book / Guidelines for Rockwell Controller Products	CL-E-Rockwell-Controller	2009-09-21	G1.0	_____
Program Book / Guidelines for Siemens Controller Products	CL-E-Siemens	2009-09-15	G1.1	_____
Program Book / Guidelines for Banner Safety Products	CL-Banner-Safety	2009-08-24	G1.0	_____
Program Book/Guidelines for Euchner Safety Products	CL-E-Euchner	2009-09-03	G1.0	_____
Program Book / Guidelines for Pilz Automation Safety Products	CL-E-Pilz	2009-11-02	G1.1	_____
Program Book / Guidelines for Sick Safety Products	CL-Sick-Safety	2009-08-24	G1.0	_____
Program Book / Guidelines for Hirschmann Ethernet Switches	CL-E-Hirschmann	Latest	G2.0	_____
Program Book / Guidelines for Cognex Vision Systems	CL-E-Cognex Vision	Latest	G 2.0	_____
Program Book / Guidelines for Microscan Vision Systems	CL-E-Microscan Vision	2008-11-24	Ver 2.0	_____
Program Book / Guidelines for Telesis Park Markers	CL-E-Telesis	2008-11-03	Ver 3.1	_____
Program Book / Guidelines for Technifor Park Markers	CL-E-Technifor	2006-01-31	Ver 2.0	_____
Program Book / Guidelines for Banner Sensors/Indicators Components	CL-E-Banner-Sensors-Indicators	Latest	Global	_____
Program Book / Guidelines for Balluff Components	CL-E-Balluff	Latest	Global	_____
Program Book / Guidelines for IFM Efeotor Components	CL-E-IFM Efeotor	Latest	Global	_____



<b>GMPT Document</b>	<b>GF6 F269 Transmission Case Machining</b>	<b>Supplier Compliance Confirmation</b> (YES – Comply) (NO - Deviation Request Required)		
----------------------	---	--	--	--

<b>Program Book / Guidelines for Rockwell Magnetics &amp; General Components</b> (slash-rated 480/277V not allowed)	<b>CL-Rockwell-Components</b>	<b>Latest</b>	<b>Global</b>	_____
<b>Program Book / Guidelines for Schneider Electric Magnetics &amp; General Components</b> (slash-rated 480/277V not allowed)	<b>CL-Schneider-Components</b>	<b>Latest</b>	<b>Global</b>	_____
<b>Program Book / Guidelines for Siemens Magnetics &amp; General Components</b> (slash-rated 480/277V not allowed)	<b>CL-Siemens-Components</b>	<b>Latest</b>	<b>Global</b>	_____

Regarding these requirements, retooled equipment shall comply with the specifications to which they were built.

The plant power distribution systems include Delta-ungrounded and Wye-Star-Resistive-Neutral, and these systems require either straight-rated components (480V), or machine isolation transformers. Retooled machine with slash-rated components shall include machine isolation transformers, or shall replace slash-rated (480/277) components with straight-rated (480) components.

### 8.2.2 FLUID POWER COMPONENT LISTS AND PROJECT BOOKS

<b>Program Book/Guidelines for Bosch-Rexroth Hydraulic Products</b>	<b>CL-F-Bosch Rexroth</b>	<b>2009-09-15</b>	<b>G1.0</b>	_____
<b>Program Book/Guidelines for Parker Hydraulic Products</b>	<b>CL-F-Parker</b>	<b>Latest</b>	<b>Global</b>	_____
<b>Program Book/Guidelines for Asco Numatics Pneumatic Products</b>	<b>CL-F-AscoNumatics</b>	<b>2009-09-11</b>	<b>G1.0</b>	_____
<b>Program Book/Guidelines for SMC Pneumatic Products</b>	<b>CL-F-SMC</b>	<b>2009-09-15</b>	<b>G1.0</b>	_____
<b>Program Book/Guidelines for SFK (Vogel) Lubrication Products</b>	<b>CL-F-SKF (Vogel)</b>	<b>2009-09-15</b>	<b>G1.0</b>	_____
<b>Program Book/Guidelines for Trabon Lubrication Products</b>	<b>CL-F-Trabon</b>	<b>Latest</b>	<b>Global</b>	_____

Regarding these requirements, retooled equipment shall comply with the specifications to which they were built.

### 8.2.3 MECHANICAL AND PROCESS EQUIPMENT COMPONENT LISTS AND PROJECT BOOKS

<b>Project Book / Guidelines for Elite Engineering Socket Tray</b>	<b>CL-M-Elite Engineering</b>	<b>2009-05-20</b>	<b>Ver 1.0</b>	_____
<b>Project Book / Guidelines for Atlas Copco Assembly Systems</b>	<b>CL-M-AtlasCopco Fastening Systems</b>	<b>2008-09-23</b>	<b>Ver 1.2</b>	_____
<b>Project Book / Guidelines for Bosch Tightening Systems</b>	<b>CL-M-Bosch Tightening System</b>	<b>2008-10</b>	<b>Ver 1.1</b>	_____
<b>Project Book / Guidelines for Cooper Power Tools Fastening</b>	<b>CL-M-Cooper Fastening Systems</b>	<b>2008-10-01</b>	<b>Ver 1.0</b>	_____



<b>GMPT Document</b>	<b>GF6 F269 Transmission Case Machining</b>	<b>Supplier Compliance Confirmation</b> (YES – Comply) (NO - Deviation Request Required)		
----------------------	---	--	--	--

Process Fluid Component Suppliers	CL-P-Process Fluid Component Suppliers	2008-09-18	G1.0	_____
-----------------------------------	---	------------	------	-------

## 9.0 GMPT PROJECT APPLICATION NOTES

Powertrain Drawing Validation Tools BOM (Stocklist) Validator	GMPT Drawing Spec Support Files on gmsupplypower.com	Website	Latest	_____
Equipment Bill of Materials (Spare Parts List)	AN-G-Maintenance Calculations	2008-07-14	G1.0	_____
Visual Management Examples for Maintenance of Machinery and Equipment	AN-G-Maintenance Visual Management	2008-07-16	G1.0	_____
Controls AutoCAD Menus & Component Symbol Library .zip file includes instructions for installation of the executable file	gmptacadversion13.zi p	2002-09-18	Ver 1.3	_____
Measurement Systems Specification Application Note	AN-Q-MSS-Global	2009-06-05	G1.0	_____
Machine Runoff and Acceptance	AN-Q-MARO-Global	2009-03-04	G1.0	_____
Global Lockout Placard Tool	g-Plac	2008-03-07	Ver 3.1	_____
Engineer's Guide to OEM Requirements for Plant Floor Controls Systems	Engineers_Guide_to_ PFC_Equipment_Requ irements_12_2.pptx	2009-12-03	Latest	_____

## 10.0 GMPT PROJECT FORMS

Technical Data for Export Compliance CNC Machine	FM-G-CNC-Export- Compliance	2008-05-19	G1.1	_____
Technical Data for Export Compliance Coordinate Measuring Machine	FM-G-CMM-Export- Compliance	2008-05-19	G1.1	_____
Technical Data for Export Compliance Robot	FM-G-Robot-Export- Compliance	2008-05-19	G1.1	_____
Technical Data for Export Compliance Miscellaneous Machinery & Equipment	FM-G-Misc-Export- Compliance	2008-06-11	G1.1	_____
Technical Documentation Deliverables	FM-G-Technical Documentation	2008-07-31	G1.0	_____
Equipment Bill of Materials, including Spare Parts	FM-G-BOM	Latest	Latest	_____
Supplier Deviation Request	FM-G-Supplier Deviation	2001-02-28	Ver 1.0	_____



<b>GMPT Document</b>	<b>GF6 F269 Transmission Case Machining</b>	<b>Supplier Compliance Confirmation</b> (YES – Comply) (NO - Deviation Request Required)		
----------------------	---	--	--	--

Supplier Training Summary Worksheets	FM-G-Training Summary	2007-10-02	Ver 6.0	_____
GM Preventive Maintenance (PM) Tasking Workbook & Instructions	FM-G-Tasking Workbook & Instructions	2008-07-14	None	_____
Machine Engineering & Installation Data for New Equipment Form	FM-P-Engr Inst Data	2010-01-08	G2.0	_____
Utilities Information for New Equipment Form	FM-P-Utility Info	2010-01-08	G2.0	_____
Controls Architecture Selection Form	FM-E-ControlsArchSel	None	Ver 4.0	_____
Run-off Checklists (retooled equipment: comply with checklists to which they were built)	ME_Run-Off_Checklists.xls	Global	G1.0	_____
Run-off Forms (retooled equipment: comply with forms to which they were built)	ME_Run-Off_Forms.xls	Global	G1.0	_____
Controls Project Management and Run-Off Checklists (retooled equipment: comply with checklists to which they were built)	Controls_Checklist.xls	2009-08-18	G1.0	_____
Safety Run-Off Checklists	FM-S-Safety_Checklist	2009-08-18	G1.0	_____
Ergonomic Run-Off Checklists	FM-S-Ergo_Checklist	2009-08-18	G1.0	_____

FM-P-Utility Info Addendum:

ELECTRICAL REQUIREMENTS (additional):

<b>GMPT Document</b>	<b>GF6 F269 Transmission Case Machining</b>	<b>Supplier Compliance Confirmation</b> (YES – Comply) (NO - Deviation Request Required)
----------------------	---	--

NOTE: Evaluate major controls components based on the following flow chart and quote accordingly.

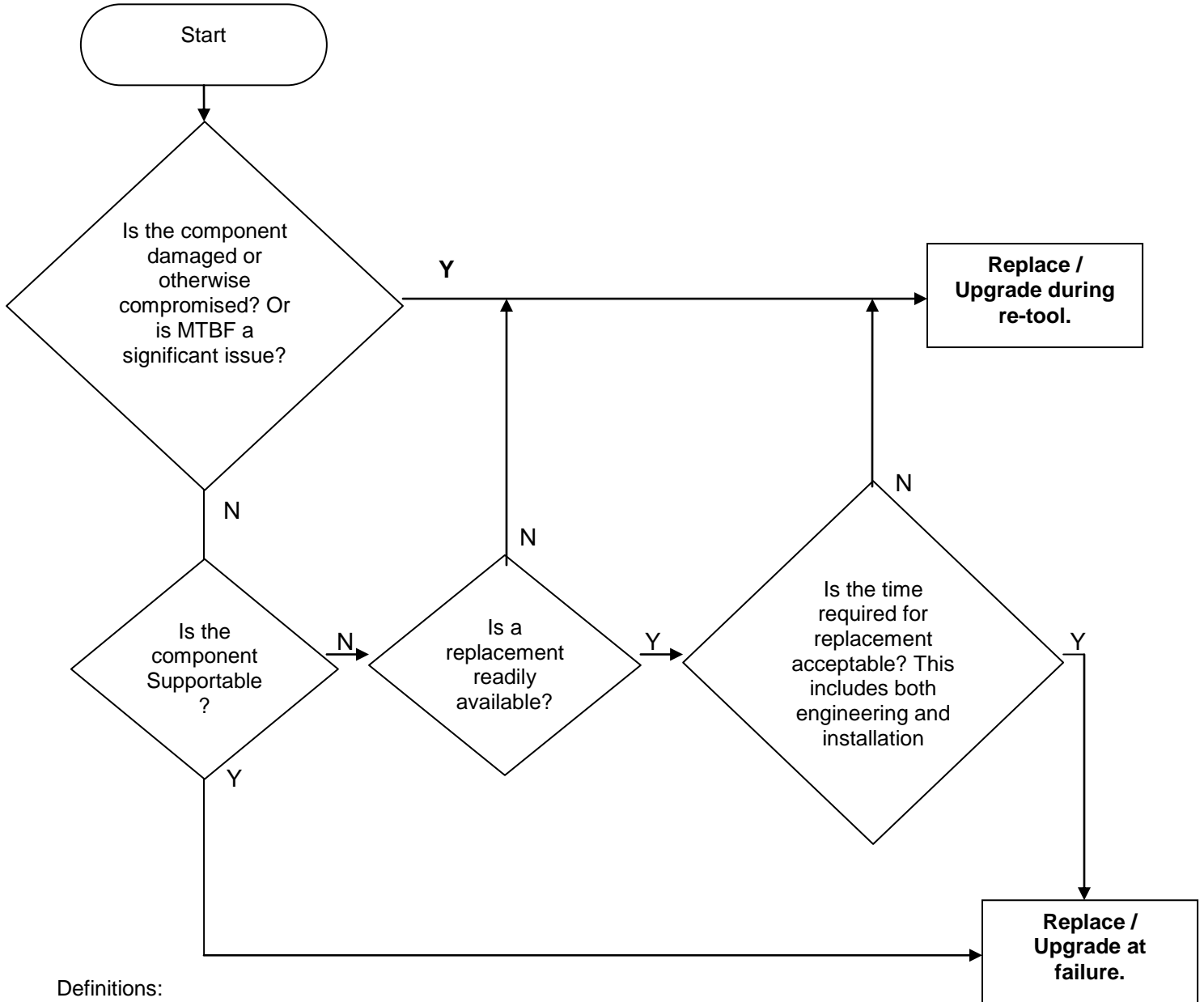

Definitions:

*Supportable* - Either by yourself or the Tier II for a period of (5) years.

*Readily available* - Component is available new or repaired within the standard delivery time for the Tier II. *Example no special production runs, or repaired units are stocked.*

*Acceptable replacement time* - (72) hours from receipt of P.O. to start of production.



### 11.0 SUPPLIER COMPLIANCE CERTIFICATION STATEMENT

<b>Project Number:</b>	[Redacted]	<b>GMPT Request for Quote Number:</b>	[Redacted]
			<b>Dated:</b>
<b>Project Description</b>	[Redacted]		

#### 11.1

"I, as an authorized agent of the Supplier, hereby certify:

- That the Supplier acknowledges that the quotation submitted in response to this Statement of Requirements (SOR) is in full compliance with the requirements of this SOR, referenced data and information, and the listed GM Standards and GMPT Specifications and Component Lists provided by GMPT with the Request For Quote except as allowed for and documented in writing within our quotation response package and submitted to GMPT for approval in accordance with GMPT change management procedures.
- That the Supplier acknowledges that the quoted machinery, equipment, and systems shall be designed and built to conform to the requirements of all applicable regulations and laws of the Local, State, Federal, Provincial, or other unit of government, of the final installation site of the equipment.
- That the Supplier acknowledges that it has informed GMPT in writing of any known equipment being provided under this SOR subject to limitations due to Export Regulations including but not limited to the Wassenaar Regulations. The Supplier agrees to provide GMPT with all information required to appropriately classify the equipment, and known Dual-Use List numbers or Munitions List Numbers for any machinery and equipment sold to GM under this SOR before shipment of the equipment to the GMPT destination site. The Supplier agrees to obtain any necessary Export Regulations licensing as required by, but not limited to, the Wassenaar Regulations to ship the equipment per schedule requirements to the GMPT destination site.
- That the Supplier acknowledges that upon award of a contract any changes, or deviations, from the requirements of this SOR, and associated GM/GMPT Standards and Specifications, data, and information included within the contract agreement shall only be implemented by the Supplier upon receipt of written authorization by GMPT and as allowed for through formal GMPT change management procedures.
- That the Supplier acknowledges that it is the Supplier's contractual responsibility to inform and manage the compliance by all subcontractors and sub-suppliers utilized by the Supplier to the requirements of this SOR, referenced data and information, GM Standards, GMPT Specifications and Components Lists, in the quotation and implementation of any resulting contract with GMPT.

Company:	Date:
	Name:
	Signature: